

A bright spotlight shines from the top center of the image, creating a triangular beam of light that illuminates the central text.

**SHOW  
CASE**

---

**EXHIBITION STAND  
CREATION**

---



# WELCOME

Welcome to the world of captivating exhibitions, where brands come alive and creativity knows no bounds.

## SHOWCASE

are pioneers of bespoke exhibition stand design and construction globally. Get ready to embark on a journey that will elevate your brand's presence to new heights.

## SHOWCASE

believes that every brand has a unique story to tell, and we are here to bring that story to life. Our team of highly skilled designers are passionate about turning your vision into a reality, creating a stand that showcases your brand's personality and values.



# INTRODUCTION

## CAPTIVATE YOUR AUDIENCE:

Attracting attention in a crowded exhibition hall can be challenging, but with our premium exhibition stands, you'll be the centre of attention. Stand tall, stand proud, and stand ahead of your competitors. Our innovative designs are tailored to your unique brand identity, ensuring your message is conveyed with maximum impact.

## UNPARALLELED QUALITY:

We understand that your brand's reputation is on the line with every event. That's why we only offer the best materials and craftsmanship to build exhibition stands that not only look impressive but are also durable and reliable. Enjoy the peace of mind that comes with knowing your investment will deliver returns.

## TAILORED TO YOUR NEEDS:

No two businesses are alike, and your exhibition stand should reflect your distinctive character. Our expert team of designers will work closely with you to understand your goals and preferences. From interactive displays to multimedia installations, we'll turn your vision into reality and create an exhibition stand that perfectly aligns with your brand message.





# INTRODUCTION



Welcome

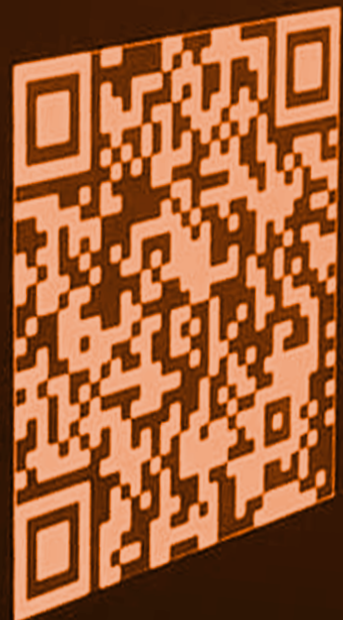

## MAXIMIZE YOUR ROI:

Participating in exhibitions is a significant investment, and we're committed to helping you maximize your returns. Our strategically designed stands will engage your target audience, generate leads, and increase footfall to your booth. By making your brand memorable, you'll enjoy a higher ROI and long term benefits.

## SEAMLESS EXECUTION:

We take the stress out of the process. From initial concept to final execution, our team will handle every detail of your exhibition stand. We'll manage logistics, setup, and dismantle, allowing you to focus on what you do best – showcasing your products and services to potential customers.

## GREEN AND SUSTAINABLE:

Sustainability is a priority for us. Our exhibition stands can be built with eco-friendly materials, reducing your environmental impact while sending a positive message about your brand's values. Stand out not just for your products but also for your commitment to a greener future.



# PICTURE THIS

## PICTURE THIS:

A captivating and immersive space that effortlessly draws visitors in, leaving a lasting impression. With our expertise in crafting exceptional exhibition stands, we are committed to making your brand stand out from the crowd.

## YOUR SUCCESS IS OUR SUCCESS:

We understand that your exhibition stand is not just a physical space but a strategic marketing tool. Our team works closely with you to grasp your objectives, ensuring that every element of the design aligns with your marketing goals.

*"Things I most like about Showcase – their attitudes towards the job. I've worked with Showcase on many events, and their attitude remains the same. No matter how small or big the job, they give it all of their attention, they provide the best service level, and treat each job with the up-most importance going above and beyond despite the size of the event."*

- ASCENTIAL EVENTS





# THE PROCESS

## OUR PROCESS:

Our process is transparent and collaborative, ensuring that you are involved every step of the way. From the initial design concept, through the development stages right up until the final build, we keep communication open, making sure that the end result exceeds your expectations.

## EFFICIENCY:

Time is of the essence when it comes to exhibitions. Our efficient and dedicated team handles the entire installation and dismantling process, allowing you to focus on making meaningful connections with your visitors.

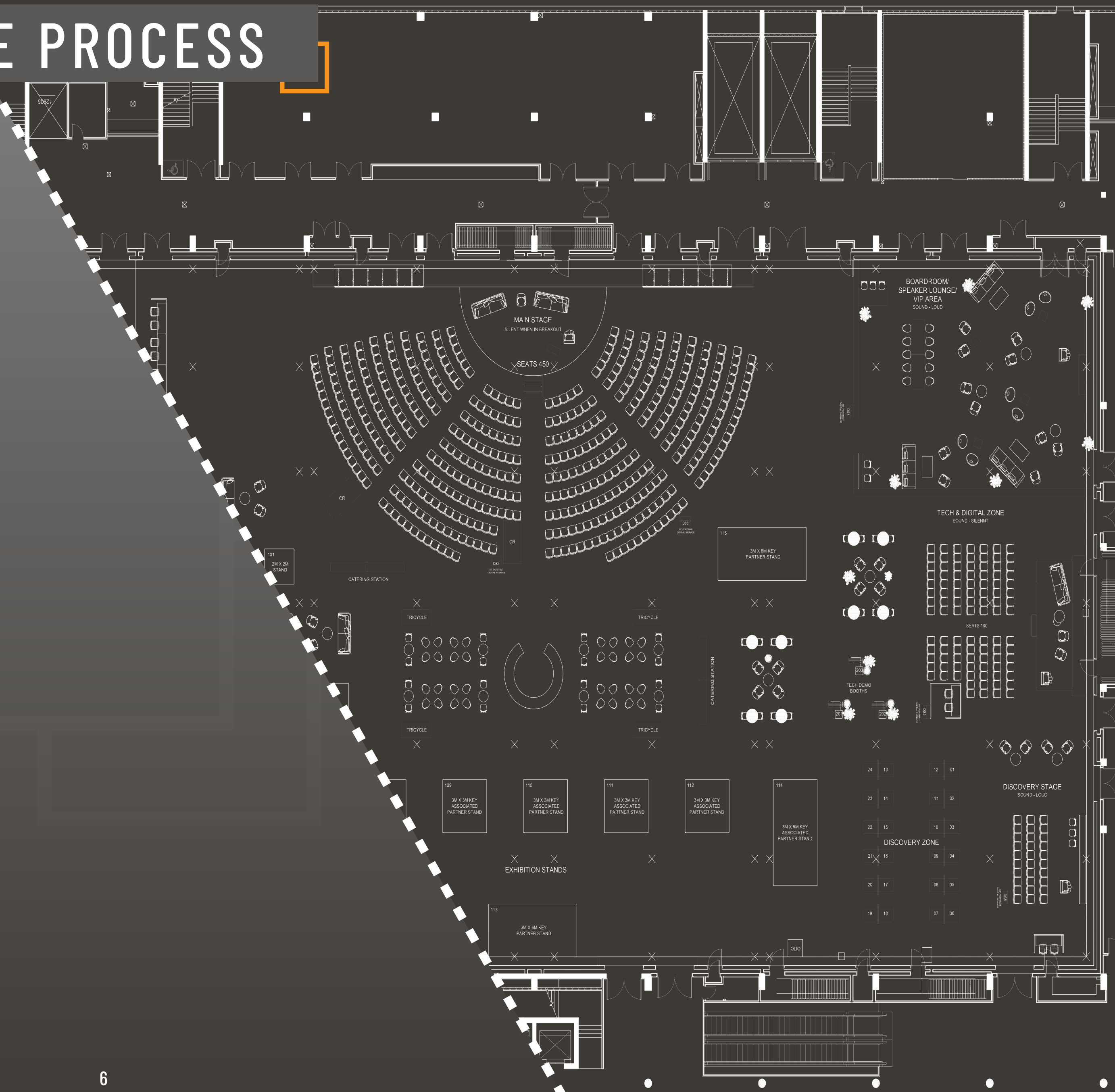



# TYPES OF STANDS

Modular and Bespoke/Custom build exhibition stands are two different approaches to creating displays for events and trade shows. Each has its advantages and considerations, and the choice between the two depends on various factors such as budget, branding needs, flexibility, and event requirements.

Let's explore the differences between the two...

## MODULAR

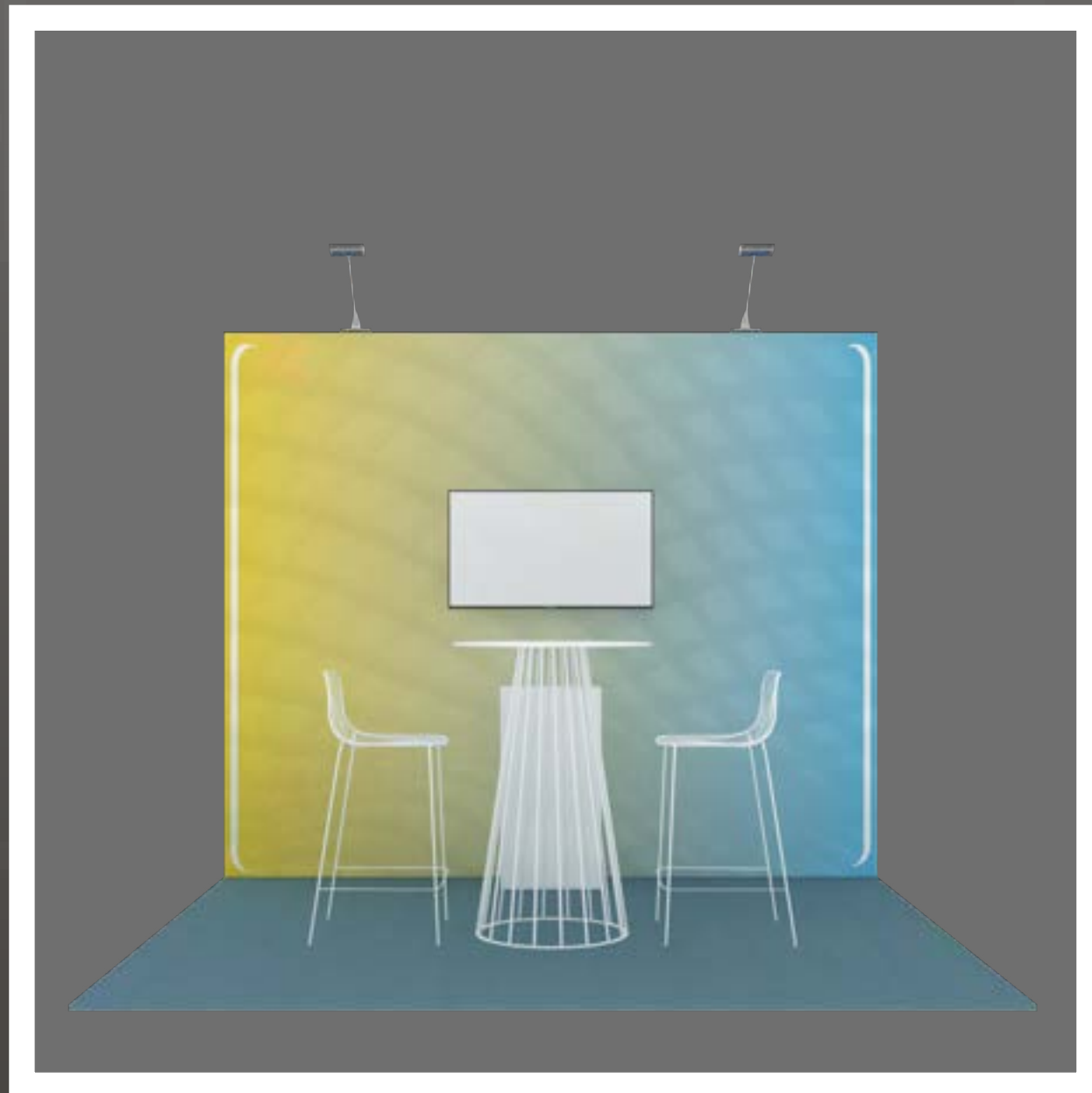

## BESPOKE BUILD





# MODULAR

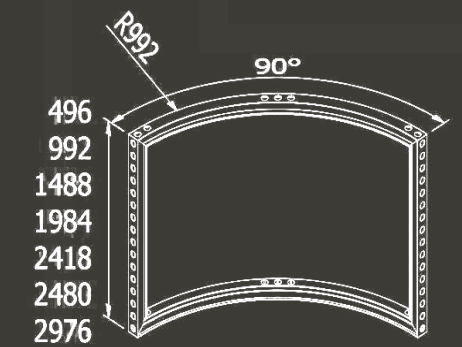
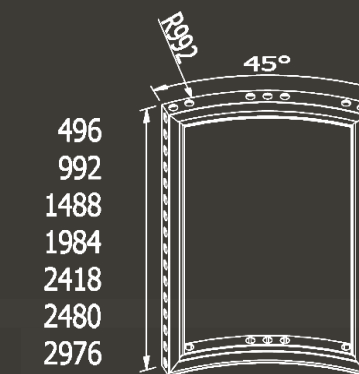
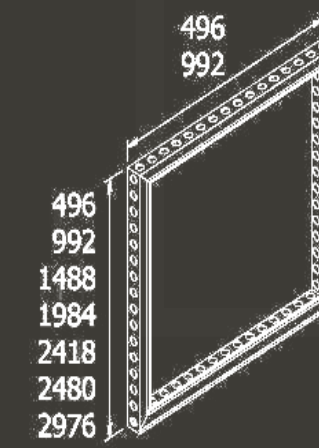

## MODULAR BUILD:

A modular exhibition stand is constructed using pre designed and pre-engineered components that can be assembled in various configurations. While there is some room for customisation, it may not be as flexible as a bespoke build.



# MODULAR

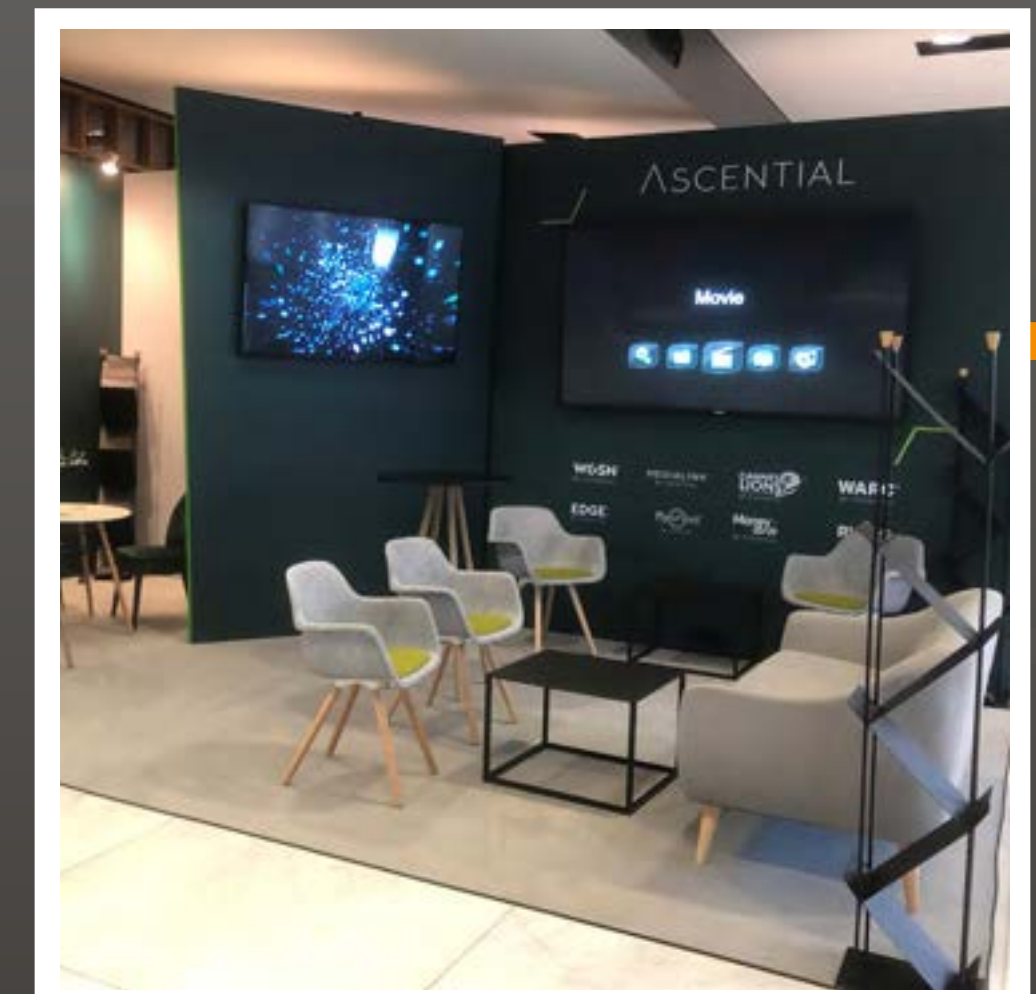
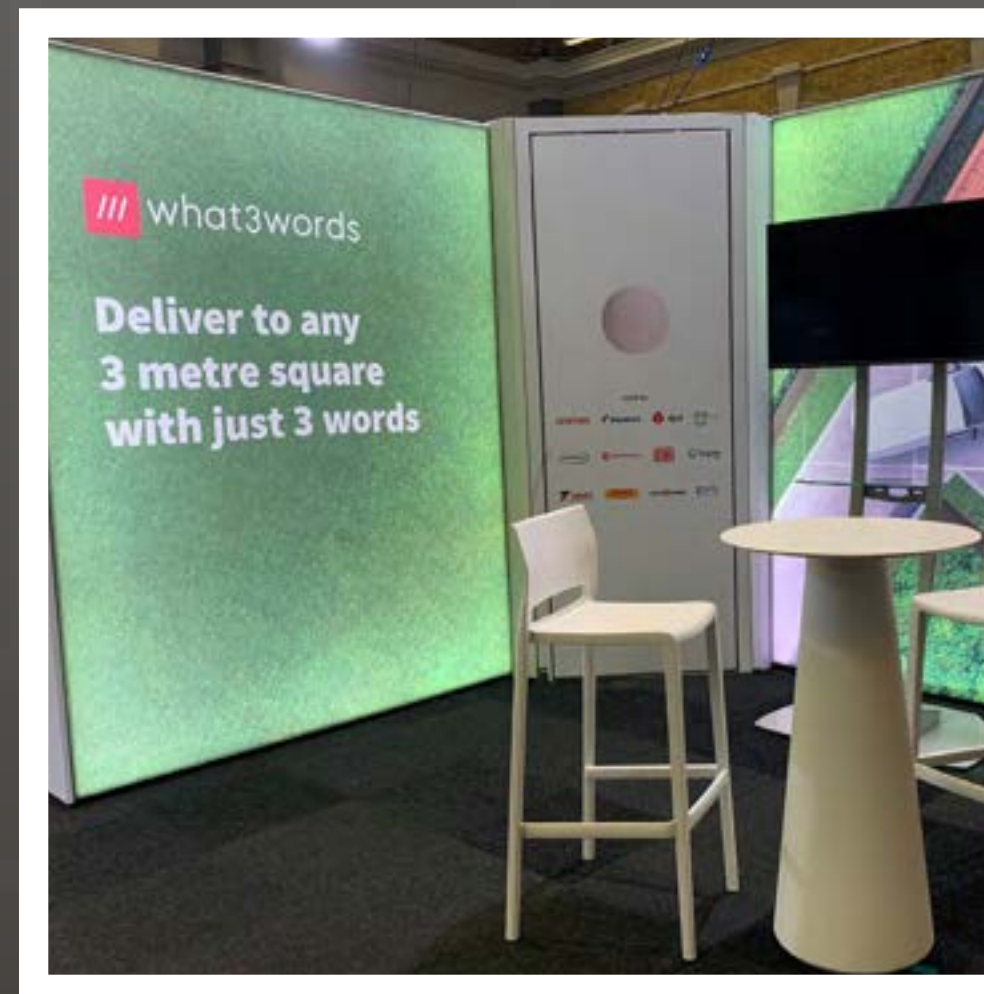



# BESPOKE

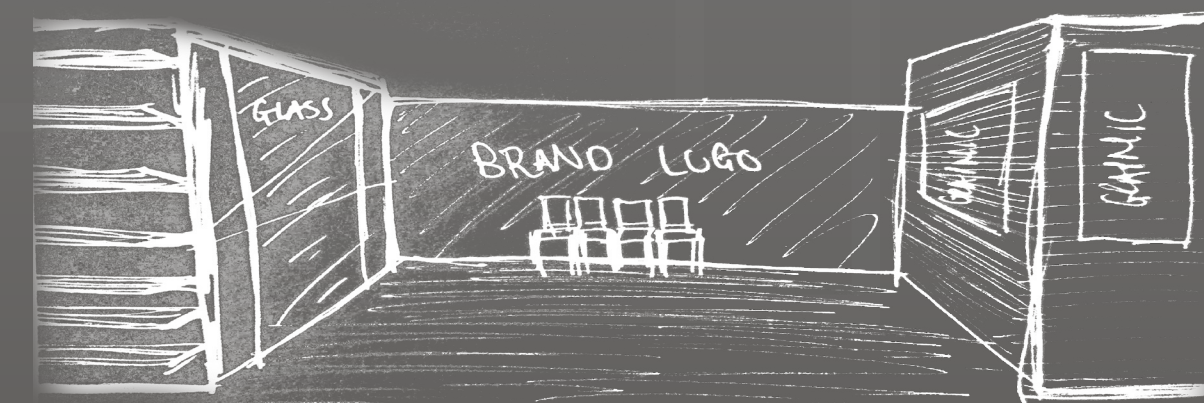

## BESPOKE BUILD:

A bespoke exhibition stand is custom-designed and built from scratch to meet specific requirements. It offers complete freedom in design, allowing for a unique and tailored look that perfectly aligns with the brand's identity and marketing objectives.



# BESPOKE

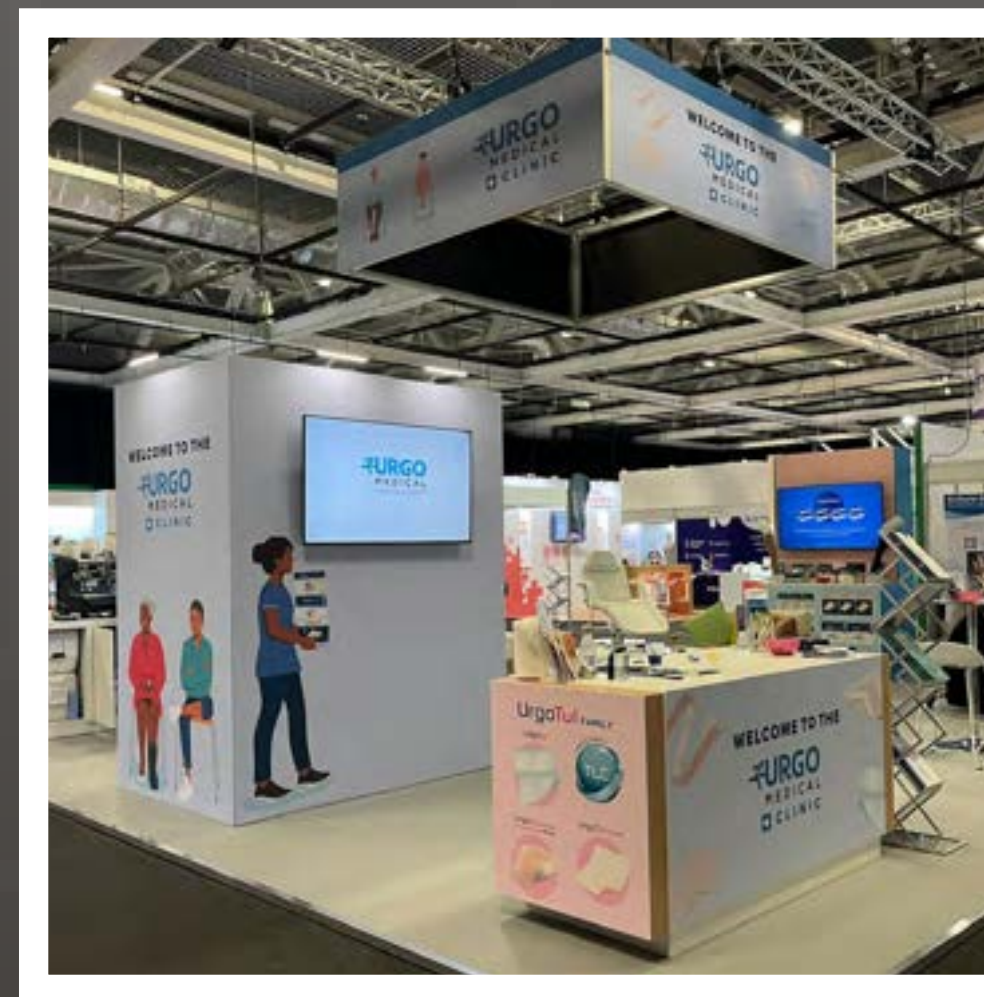
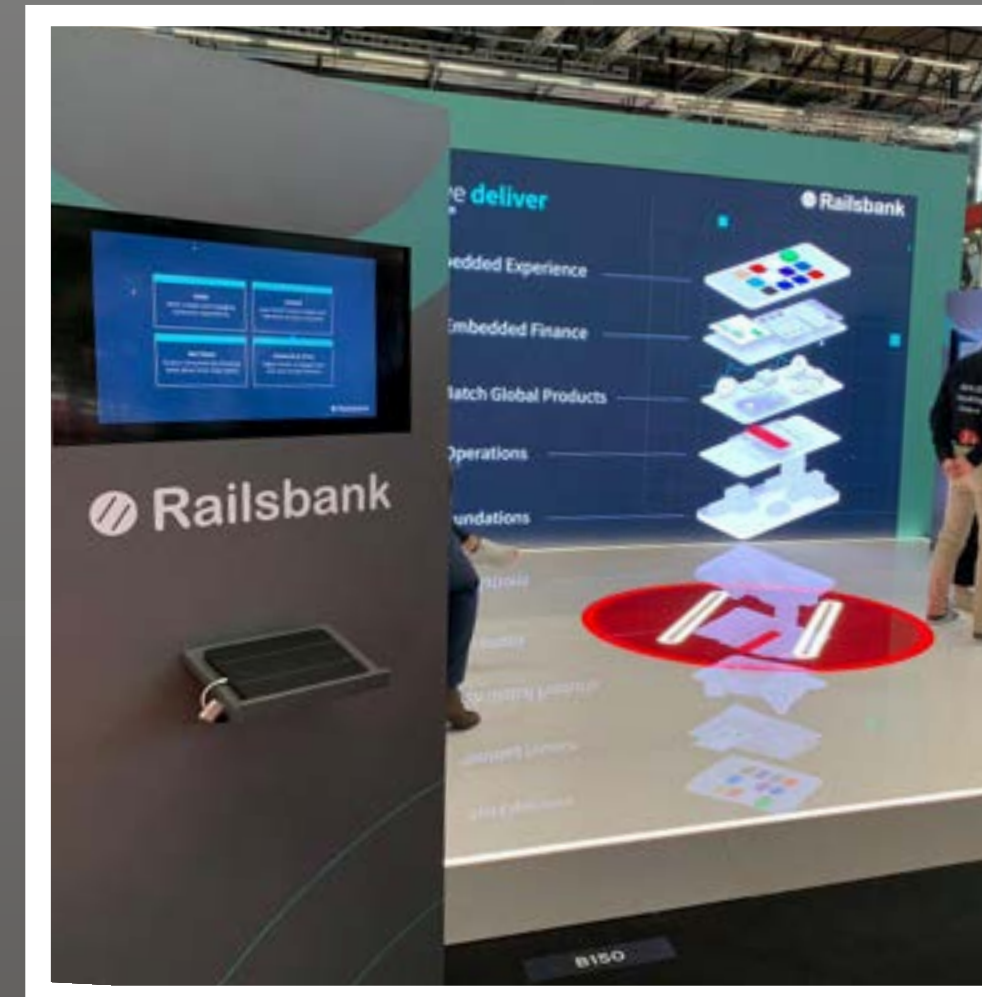
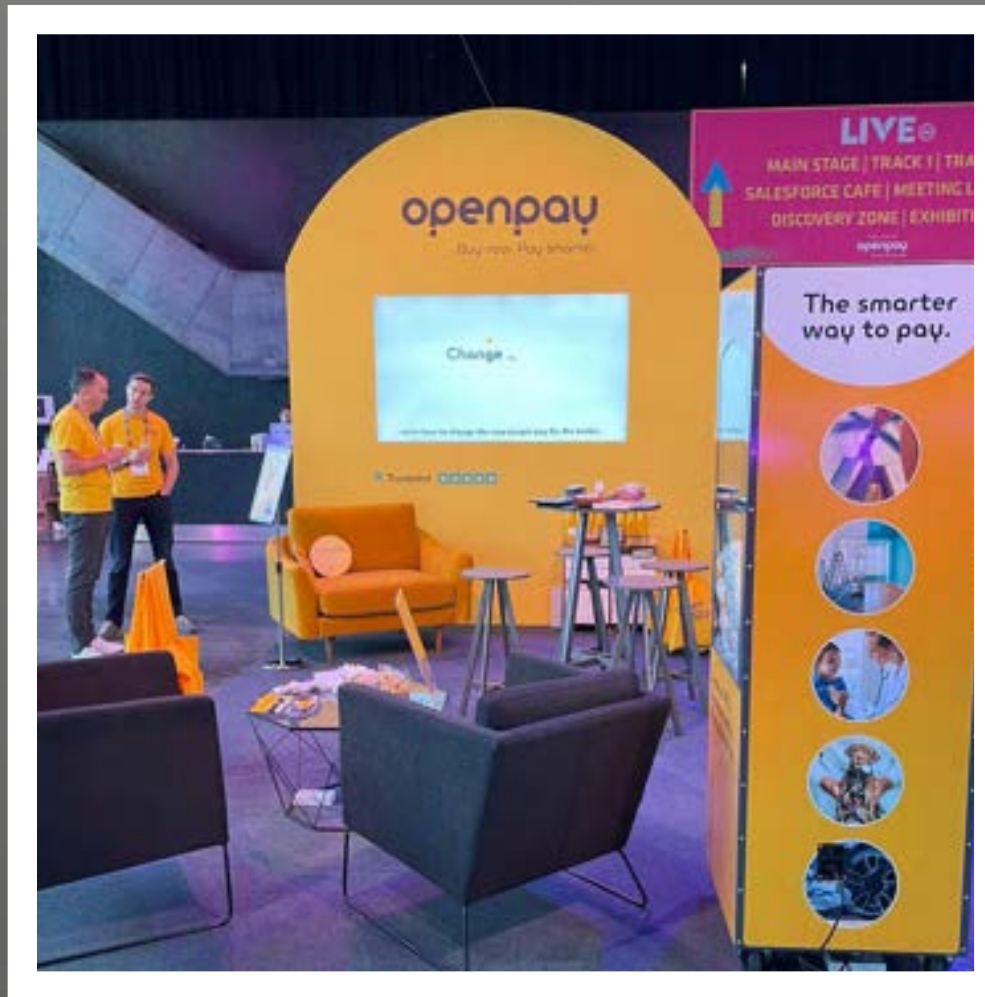



# DESIGN EXAMPLES

MODULAR?





# DESIGN EXAMPLES



BESPOKE



# DESIGN EXAMPLES

BESPOKE





# DESIGN EXAMPLES



MODULAR + BESPOKE



# DESIGN EXAMPLES

MODULAR + BESPOKE





# DESIGN EXAMPLES

BESPOKE

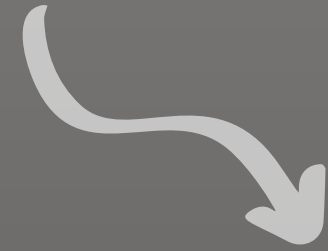



# DESIGN EXAMPLES

BESPOKE

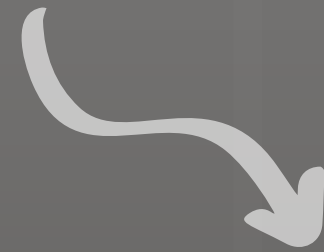



# DECISIONS ON

## CUSTOMISATION

### MODULAR

A modular exhibition stand is constructed using pre-designed and pre-engineered components that can be assembled in various configurations. While there is some room for customisation, it may not be as flexible as a bespoke build.

### BESPOKE BUILD:

A bespoke exhibition stand is custom designed and built from scratch to meet specific requirements. It offers complete freedom in design, allowing for a unique and tailored look that perfectly aligns with the brand's identity and marketing objectives.

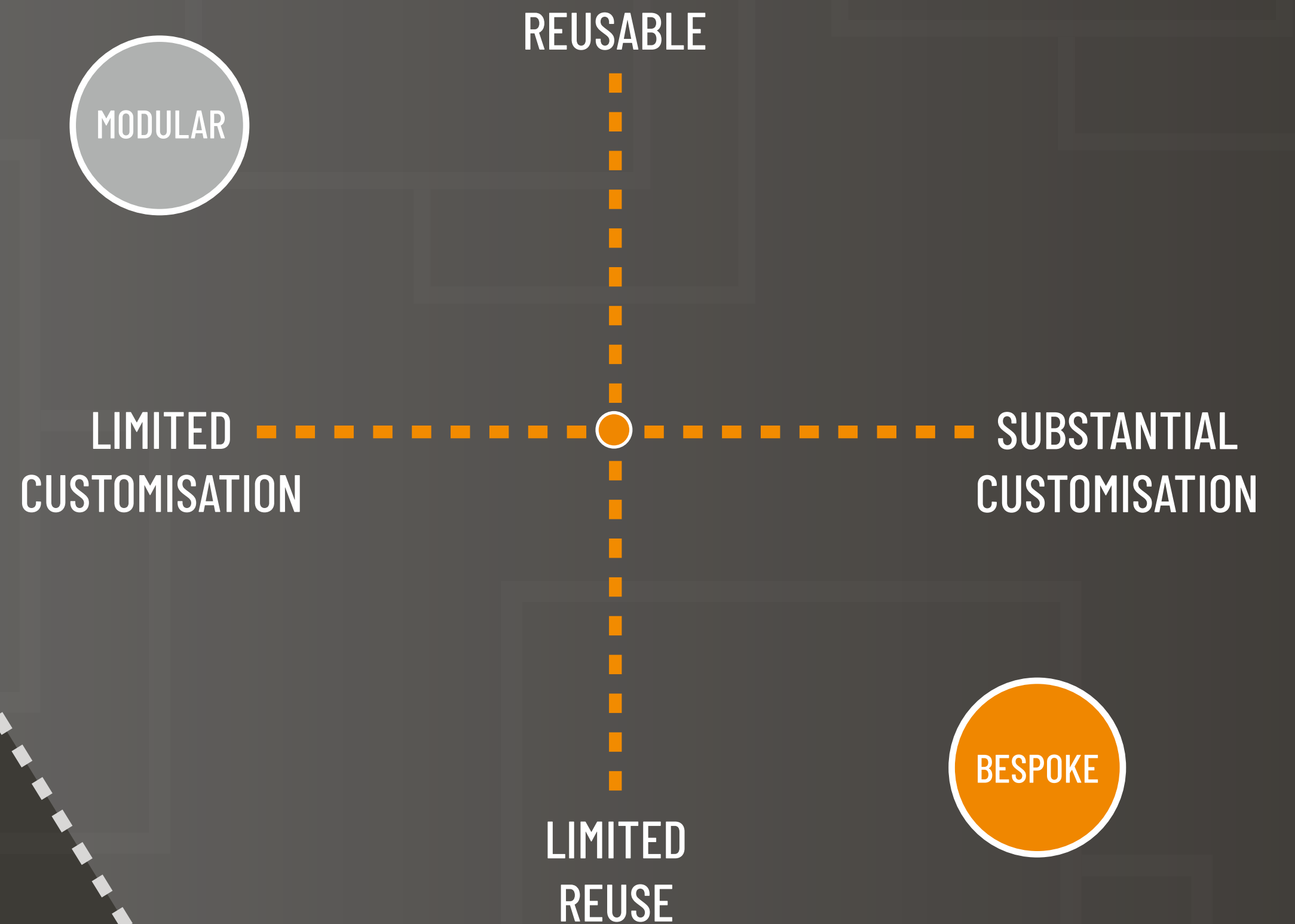



# DECISIONS ON

## REUSABILITY

### MODULAR

Modular stands are designed to be reusable and adaptable for various events. They can be easily reconfigured and rebranded to suit different exhibition spaces and requirements.

### BESPOKE BUILD:

Bespoke Build: Bespoke stands are typically designed for a specific event and may not be easily reused for other shows without significant modifications or adaptations.

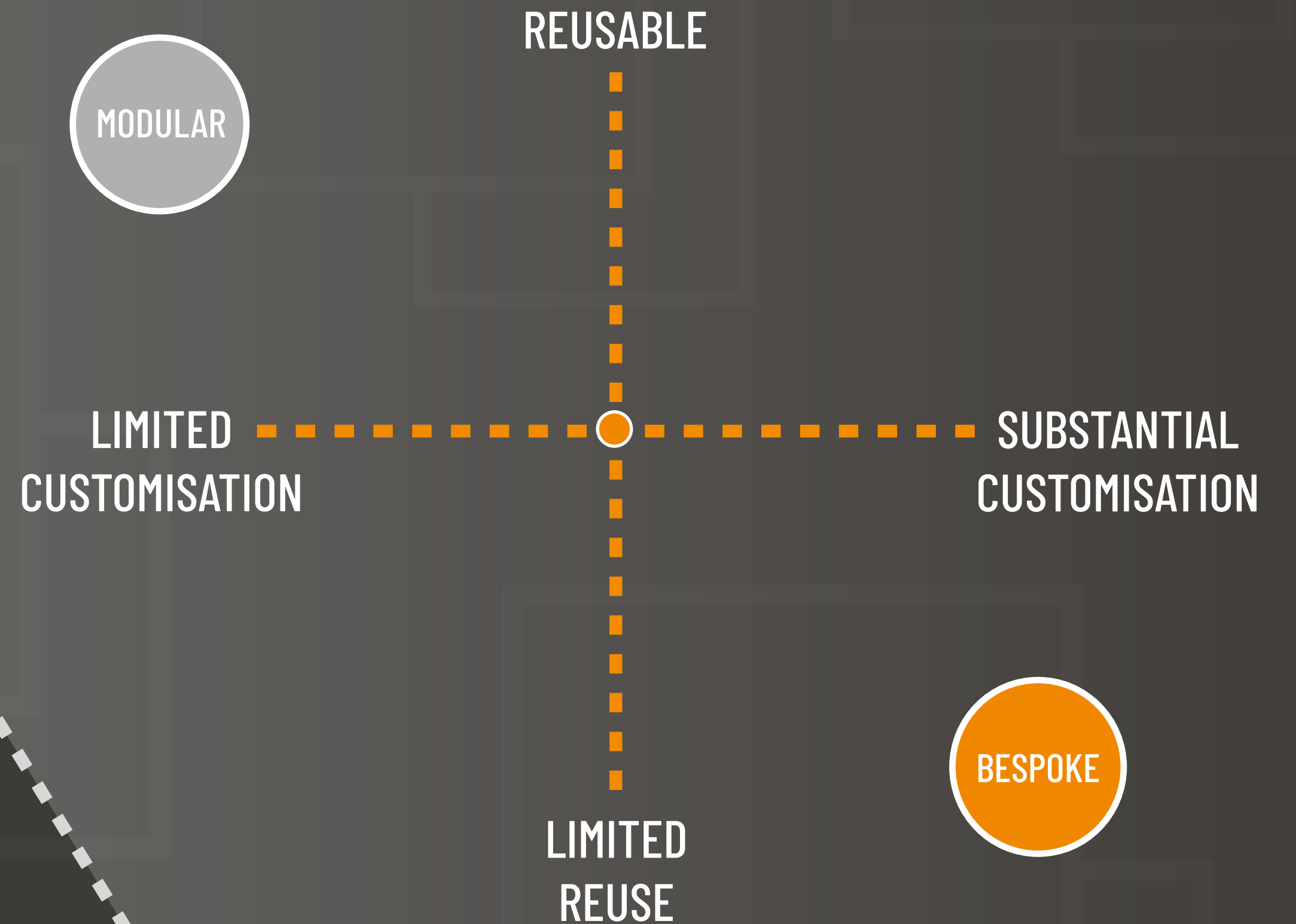



# DECISIONS ON

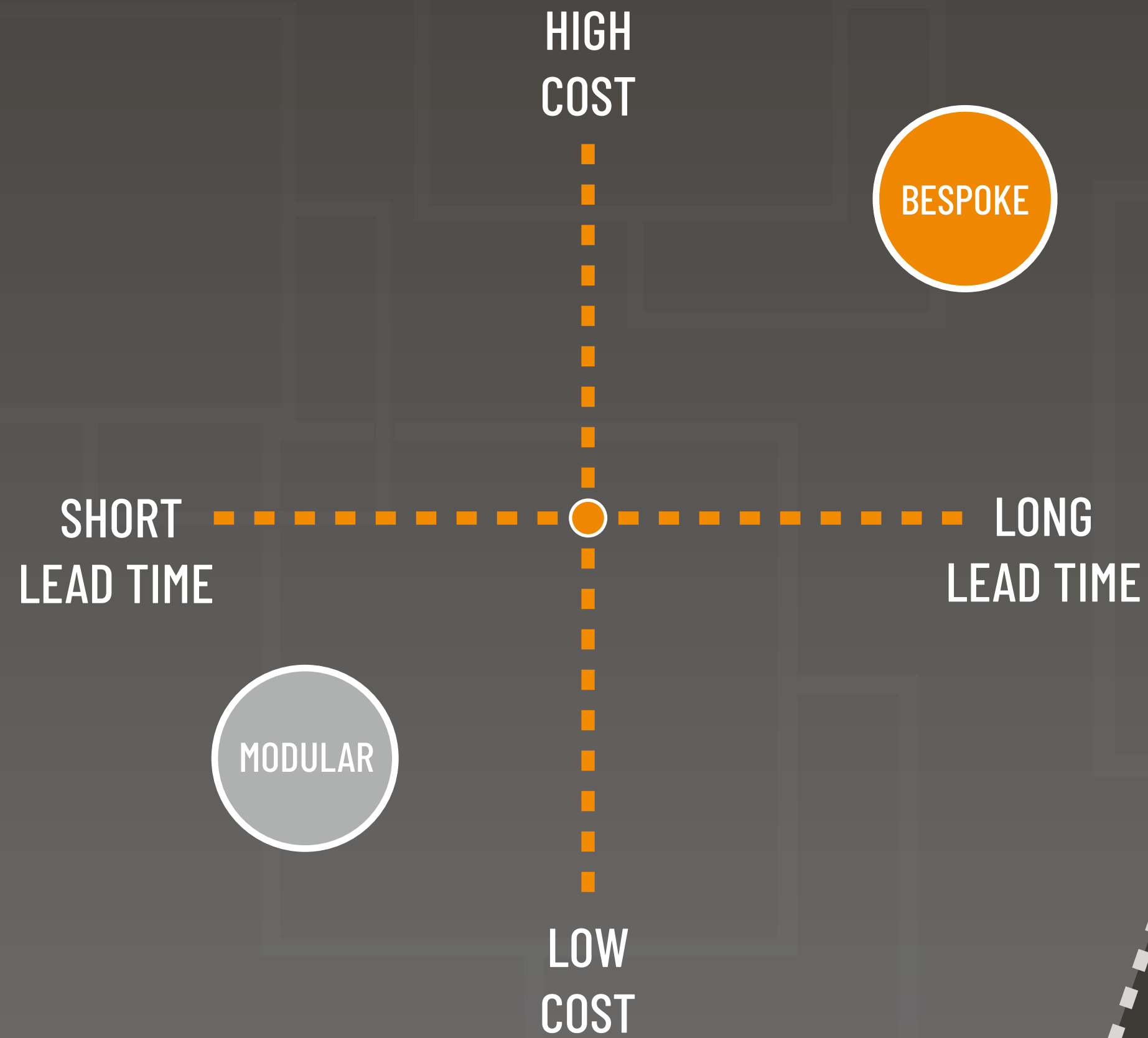

## COST

### MODULAR

Modular stands are generally more cost-effective since they reuse standardised components, reducing design and production expenses. This makes them a popular choice for smaller businesses or those with limited budgets.

### BESPOKE BUILD:

Custom-designed stands usually involve higher costs, as they require unique design, materials, and labour. This option is more suitable for businesses with larger budgets.



# DECISIONS ON

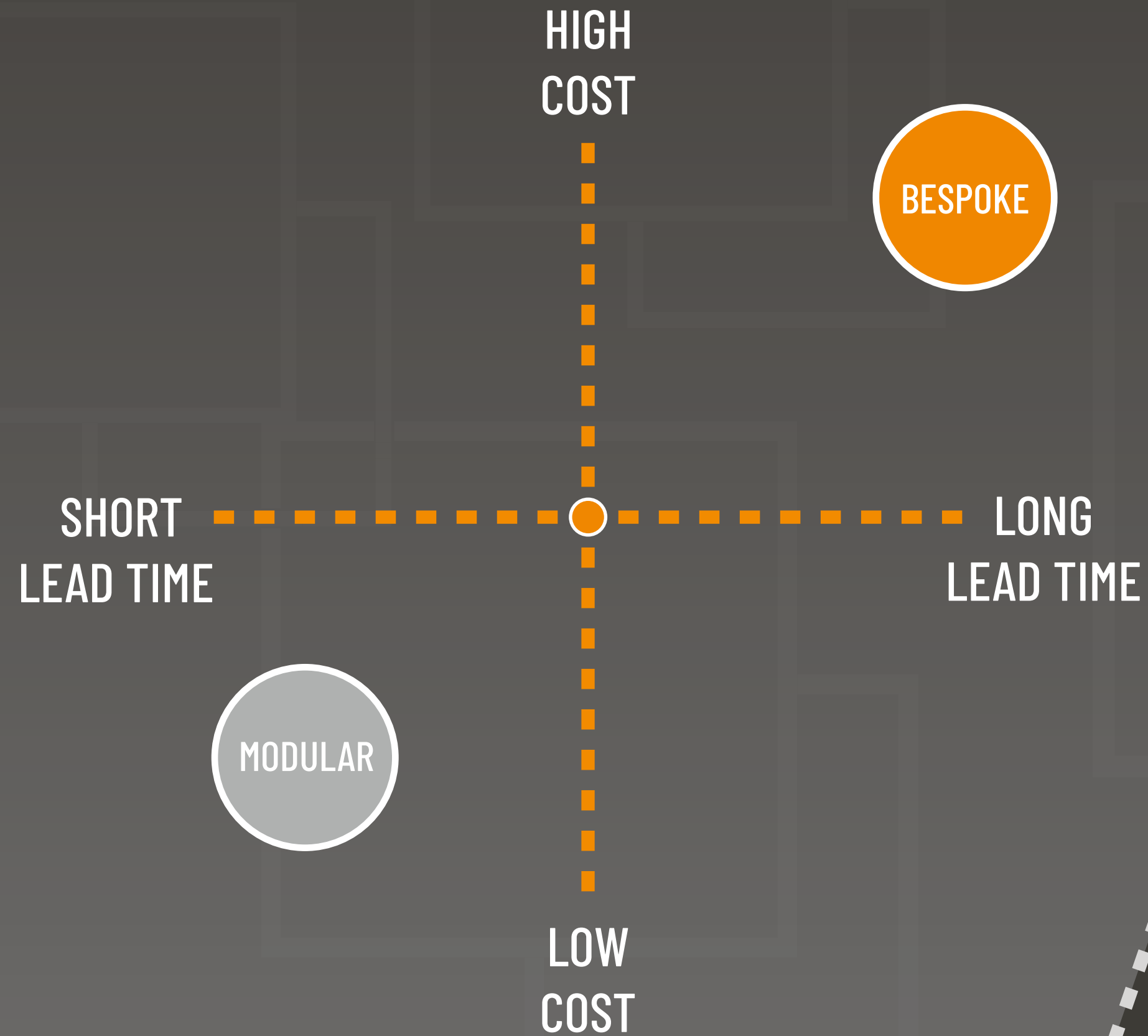

## LEAD TIME

### MODULAR:

Modular stands can be assembled quickly since the components are pre-designed and readily available. This reduces lead time and is beneficial for companies with tight schedules.

### BESPOKE BUILD:

Creating a custom exhibition stand from scratch can take longer due to the design and construction process. It requires more time for planning, fabrication, and testing.



# SUMMARY

In summary, a bespoke build offers complete creative freedom and tailor-made solutions but comes with higher costs and longer lead times. On the other hand, modular stands are more cost-effective and quicker to set up, but they may have some limitations in design and customisation. Companies should consider their specific needs, budget, and event requirements when choosing between these two options.

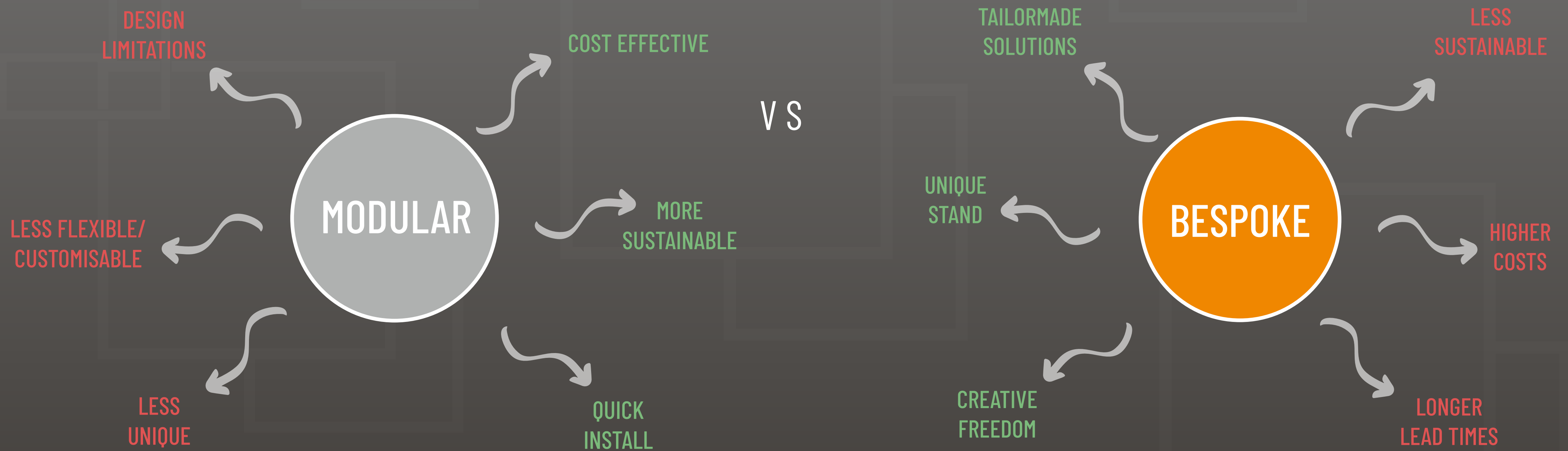



## COST GUIDE

The below illustration is a **GUIDE ONLY** to the potential costs. Exhibition stand prices vary, and what you'll pay will depend on a range of factors, including your plans for your trade show booth design, location, how large you want your stand, how quickly you want it, whether you decide to hire or buy or re-use your stand for future events. Options to store your stand are available too

Choosing **SHOWCASE** to help design your professional display is a worthwhile investment, no matter how much you choose to spend. We design and build exhibits of the highest quality and help you find the best way to get the most out of your investment.

Please contact us for a non-obligation quote:

Modular from £4,000 + VAT dependant on size  
Be-spoke £15,000 + VAT dependant on size.

\*THE ABOVE IS FOR ILLUSTRATION PURPOSES ONLY. COSTS ALLOW FOR A BUILD IN UK ONLY.\*



# SUSTAINABILITY

At Showcase we understand the importance and urgency of tackling the climate crisis, that's why we have made a commitment to reduce our environmental impact.

We have forged key partnerships with organisations and companies who share our passion for the environment teaming up for our **#DrivingSustainabilityTogether** campaign, to promote palm oil free HVO fuel.

We believe that by continuously improving and reviewing our polices we can make a difference.



FS 584720 ISO 9001:2015



OHS 638683 ISO 45001:2018



EMS 602249 ISO 14001:2015

We don't just do events we create them, and we want to inspire all those involved in our events to create an environmentally friendly way of working.

To find out more about our sustainability credentials and values, please click below

[weareshowcase.com/sustainability](http://weareshowcase.com/sustainability)





CONTACT US

BOOK YOUR  
SUCCESS  
TODAY

Don't miss the chance to elevate your brand and make a significant impact at your next exhibition. Our team is eager to discuss your requirements and develop a custom-designed exhibition stand that will turn heads and drive results.

Call us today at **020 3826 6110** or visit our website [www.weareshowcase.com](http://www.weareshowcase.com) to schedule a consultation. Remember, your success is our success, and we can't wait to embark on this journey together!



# SHOW CASE



FS 584720 ISO 9001:2015



OHS 638683 ISO 45001:2018



EMS 602249 ISO 14001:2015

**UK | EUROPE | UAE | ASIA**

**Head Office:** Paslow Hall Farm Estate, King Street, High Ongar Essex CM5 9QZ  
| **T** 020 3826 6110 | **E** [hello@weareshape.com](mailto:hello@weareshape.com) | **weareshape.com**