



PRODUCT RANGE 2023

**AGRICULTURE | SPORTS TURF |
ESTATE MANAGEMENT**



more than tractors



The name **KIOTI** is derived from the word for the North American Coyote, and is **the export** brand of the Daedong Corporation from South Korea. Founded in 1947, the company has a production capacity of over 40,000 tractors per year and has been building :

- agricultural machinery for over 75 years;
- diesel engines for over 65 years;
- tractors for over 55 years.

The Daedong Corporation is now a leader in agricultural technology, compact tractors, multi-purpose vehicles (UTVs) and lawn and property maintenance (ZTRs).

Daedong Corporation's focus is on the development and construction of high-quality, environmentally friendly diesel engines, modern tractors, UTVs and ZTRs. This is supported by various certificates of the EPA and the EEC, as well as by the ISO certificates ISO9001 and ISO14001.

First-class machines, outstanding service and competitive pricing: more than 1,400 people work across the world to help achieve these outcomes every day. Tens of thousands of farmers, gardeners and landscapers, municipalities, service providers, hunters and hobby farmers successfully use **KIOTI** machines worldwide.

Tractors, UTVs and ZTRs from KIOTI – your perfect companion!

Why? At **KIOTI**, we produce almost all the components for our machines ourselves. Daedong Corporation has been manufacturing complete powertrains (motors, transmissions, axles) for several decades and purchases very few assemblies. This enables us to manufacture components and machines to an extremely high quality, which allows KIOTI to offer outstanding warranty on our machines as standard:

Tractors - 5 years' warranty

- **Years 1 - 2: entire tractor, regardless of the number of operating hours.**
- **Years 3 - 5: entire powertrain, including the engine, with a max of 3,000 operating hours.**

UTVs - 2 years' warranty

- **Years 1 - 2: entire UTV, regardless of the number of operating hours.**

In addition to outstanding warranty, **KIOTI UK** also offers comprehensive customer service by trained **KIOTI dealers**, providing UK-wide maintenance and services. A reliable and fast supply of spare parts is ensured by our European central warehouse in Rotterdam.

Run ahead of the pack... choose KIOTI

KIOTI UK Ltd

Unit 11 | Eltisley Business Park | St Neots | Cambridgeshire | PE16 6TB
Tel.: +44 1480 401512
www.kioti-uk.com



CS SERIES
(21–25 hp)
Page 8

CX SERIES
(25 hp)
Page 14

CK SERIES
(25–50 hp)
Page 20

DK SERIES
(45–58 hp)
Page 28

RX SERIES
(73 hp)
Page 36

HX SERIES
(91–127 hp)
Page 38

K9 SERIES
(25 hp)
Page 40

ZX SERIES
(24–25 hp)
Page 46



DAEDONG: A Success Story



1947
Foundation of DAEDONG Industrial in Jinju-si, Gyeongsangnam-do



1949
Construction of engines begins



1962
First motorised hoe manufactured in Korea



1968
First Korean tractor produced



1971
First combine harvester produced in Korea



1973
First rice transplanter manufactured in Korea



1993
Foundation of Daedong-USA Inc. (USA)



1996
ISO 9001 and ISO 14001 awarded



2009
The Mecron utility vehicle is launched



2010
Foundation of Daedong KIOTI Europe B.V. (Netherlands)



2013
Stage-IV engine manufacturing commences (CRDI)



2015
Official partner of the 2018 Winter Olympics in Pyeongchang



2018
Foundation of Daedong Canada Inc. (Canada)



2019
Daedong KIOTI (German division) Europe B.V.



2021
50,000th tractor delivered from the CK Series



2022
Additional 102,000m² factory opens in Daegu



CANADA

DAEDONG KIOTI CANADA
Distribution, Service & warehouse
for Canada, Mississauga, ON,
www.kioti.com

USA

DAEDONG USA INC.
Distribution, Service & warehouse
die USA, Wendell, NC,
www.kioti.com

EUROPE

DAEDONG KIOTI EUROPE B.V.
Distribution, Service & warehouse
for Europe, Rotterdam,
www.kioti.eu

EUROPE

DAEDONG KIOTI EUROPE B.V.
Distribution & Service
for Germany, Hamburg,
www.kioti.de

MYANMAR

BÜRO IN MYANMAR
Distribution,
Yangon, Myanmar

CHINA

**DAEDONG AGRICULTURAL
MACHINERY (ANHUI) CO., LTD.**
Distribution,
Chuzhou, Anhui, China
www.daedong.com.cn

KOREA

DAEDONG HEADQUARTERS
Seoul, Korea

DAEDONG R & D CENTRE
Changnyeong, Korea

DAEDONG TRAINING CENTRE
Changnyeong, Korea

DAEDONG MS
Production, Daegu, Korea
www.daedongmetals.co.kr

DAEDONG CORPORATION
Production, Daegu, Korea
www.daedong.co.kr

DAEDONG GEAR
Production, Sacheon, Korea
www.daedonggear.com

DAEDONG MOBILITY
Production, Anseong, Korea
www.daedongmobility.co.kr



**5 YEAR'S WARRANTY
(3,000 HOURS)**
POWERTRAIN WARRANTY
COMMERCIAL &
PRIVATE USE
KIOTI



"The manoeuvrability, ease of use and robust construction makes the CS2510 the perfect addition to our operations."

Mini-Compact Tractor

CS Series (21–25 hp)

- Environmentally friendly.
- Powerful diesel engine.
- Manual or HST transmission.
- HST- double pedal.
- Four-wheel drive.
- Folding ROPS frame or cabin.
- Front Linkage (Optional).
- Front PTO (Optional).
- Central and rear PTO.
- Three-point linkage.
- Power steering.
- Ergonomically designed driver's seat.
- Illuminated dashboard.
- One-piece bonnet.



We were looking for a compact tractor for the winter service and maintenance of our forwarding agency's depot. The CS2510 convinced us with its versatility and high processing quality. Equipped with a snow plough and a salt spreader, the machine was able to show what it can do. In winter, we have to ensure that the trucks can manoeuvre without problems on our 10,000 square metre yard. With the help of the small Kioti tractor, we were able to ensure this quickly and easily. In cold wintry temperatures and inclement weather, the high-quality cabin is a blessing. A big plus: we can also use the machine in summer. Equipped with a front brush, we carried out a thorough cleaning of the yard and were more than satisfied with the result. The manoeuvrability, ease of use and robust construction make the CS2510 the perfect addition to our farm.

Wilfried Brodhage, Spedition Windels, Bremen



OPERATOR COMFORT

The CS series has power steering, easy to reach controls and a 12V socket, All controls are easy to reach, enhancing operator work.



ILLUMINATED DASHBOARD

Even the compact tractors of the CS series boast premium features, such as the easy-to-read illuminated dashboard.



TOOLBOX

All CS models are equipped with a toolbox as standard. Ideal for keeping tools and accessories safe and the cabin floor clear.



POWERFUL DIESEL ENGINE

The 3-cylinder diesel engine from KIOTI is fuel efficient, but still delivers sufficient power to meet your needs.



FOUR-WHEEL DRIVE

Four-wheel drive is standard on all three CS models and can be easily engaged via a control lever.



GEARBOX: MECHANICAL OR HYDROSTAT (HST)

The CS2220 has a mechanical six forward and two reverse gearbox. Whilst the CS2510 H & CS2520 HGE are equipped with a hydrostat (HST) drive, operated by twin pedals.

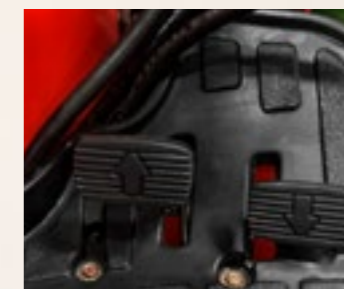

HST-LINK

The optional HST-Link couples the HST accelerator pedal to the engine speed, meaning the further the pedal is pressed, the faster the ground speed.



STATIONARY PTO OPERATION

The PTO can be operated without the driver in the seat simply by selecting S-PTO (e.g. for chopping logs, CS2520 HGE only).



Model		CS2220U-EU	CS2510H-EU	CS2520H-GE	CS2520GE/CH
		Roll bar	Roll bar	Roll bar	Cabin
Motor					
Manufacturer		KIOTI	KIOTI	KIOTI	KIOTI
Control		Mechanical	Mechanical	Mechanical	Mechanical
Emissions tier		5	5	5	5
Maximum power (ECE-R120)	hp (kW)	21.3 (15.7)	24.8 (18.3)	24.8 (18.3)	24.8 (18.3)
Number of cylinders		3	3	3	3
Engine displacement	cc	1,007	1,007	1,007	1,007
Rated speed	rpm	3,200	3,200	3,200	3,200
Turbocharger		No	No	No	No
Fuel tank	l	23.5	25.5	25.5	25.5
Power-train					
Transmission		Mechanical gearbox	HST - Hydrostatic	HST - Hydrostatic	HST - Hydrostatic
Number of gears or HST ranges		6F x 2R	2 ranges	2 ranges	2 ranges
Shuttle Type		-	-	-	-
Maximum speed (forward)	km/h	1.1-19.3	0-16.5	0-16.5	0-16.5
Four-wheel drive		Std.	Std.	Std.	Std.
Differential lock		Std. (rear axle)	Std. (rear axle)	Std. (rear axle)	Std. (rear axle)
Steering type		Hydr. Power steering	Hydr. Power steering	Hydr. Power steering	Hydr. Power steering
PTO					
Rear PTO	rpm	540	540	540	540
Rated PTO power	hp	17.6	18.7	18.7	18.7
Rear PTO clutch		Foot clutch	Mech. engagement	Elec- hydr. engagement	Elec- hydr. engagement
Mid PTO	rpm	Std. 2,200	Std. 2,200	Std. 2,200	Std. 2,200
Front PTO (from intermediate axles)	rpm	-	Opt. 2,200	Opt. 2,200	Opt. 2,200
Front PTO (by engine)	rpm	-	-	-	-
Hydraulics					
Number of double-acting spools at the rear		1 (Opt.)	1 (std.)	1 (std.)	1 (std.)
Four-way cross control lever		With front loader	With loader or front linkage.	Std.	Std.
Number of double-acting spools mid mounted		0	0	2	2
Pump power (work / steering)	l/min	25.7 (18.6 / 7)	25.7 (18.6 / 7)	26.4 (18.7 / 7.7)	26.4 (18.7 / 7.7)
Pressure	bar	140	140	140	140
Three-point linkage (rear)					
Regulation		Hydr. adjustable	Hydr. adjustable	Hydr. adjustable	Hydr. adjustable
Category		Cat 1	Cat 1	Cat 1	Cat 1
Maximum lifting capacity	kg	877	877	871	871
Lifting capacity at the coupling point (entire stroke)	kg	715	715	715	715
Lifting capacity 610mm behind coupling point (entire stroke)	kg	318	318	318	318
Three-point linkage (front)					
Available		-	Opt.	Opt.	Opt.
Category		-	Cat 0	Cat 0	Cat 0
Dimensions					
Total length (incl. three-point linkage)	mm	2,623	2,523	2,523	2,523
Width	mm	1,185 (turf tyres)	1,185 (turf tyres)	1,185 (turf tyres)	1,185 (turf tyres)
Total height (roll bar)	mm	2,285 (turf tyres)	2,285 (turf tyres)	2,285 (turf tyres)	-
Total height (cabin)	mm	-	-	-	1,981 (turf tyres)
Wheelbase	mm	1,500	1,400	1,400	1,400
Min. ground clearance	mm	234 (turf tyres)	234 (turf tyres)	234 (turf tyres)	234 (turf tyres)
Weight (roll bar)	kg	710	700	705	-
Weight (cabin)	kg	-	-	-	918
Permissible total weight	kg	1,360	1,225	1,295 -1,540	1,295 -1,540
Ab. Front axle load (max.)	kg	650	650	650	650
Ab. Rear axle load (max.)	kg	1,000	1,000	1,000	1,000
Towing capacity					
B1 - un-braked	kg	330	330	330	330
B2 - Overrun braked	kg	2,000	2,000	2,000	2,000
Extras					
Air conditioning		-	-	-	-
Swivel steering column		-	-	Std.	Std.
Cruise Control		-	Opt.	Opt.	Opt.
HST Link (HST / engine speed coupling)		-	Opt.	Opt.	Opt.
Stationary PTO operation		Std.	-	Std.	Std.



ADJUSTABLE STEERING WHEEL

The CS2520 HGE adjustable steering column allows drivers of all sizes to work comfortably.



INDEPENDENT PTO SWITCH

The independent PTO clutch on the CS2520 HGE premium model offers easy PTO engagement.



FRONT LOADER CONTROL LEVER

The CS2520 is equipped with a four-way control lever for the comfortable operation of a front loader or other ancillary equipment.



CRUISE CONTROL

Optional with the CS 2520 HGE, the electrically switch-able cruise control allows the driving speed to be fixed at the touch of a button.



RETROFIT CABIN (KIOTI)

The CS2520 HGE can be retrofitted with a KIOTI 4-post cab, offering great all-round visibility and protection from the weather.



FRONT LINKAGE & PTO (Matev)

The CS 2510 H & CS2520 HGE can be fitted with a front linkage and PTO, enabling the operation of front mounted equipment, boosting the tractor's capabilities.



FRONT MUD GUARDS

The CS2510 H and CS2520 HGE models can be fitted with optional front mud guards to protect the platform or cab from mud and water splashes.



MID-MOUNTED MOWER

Available for all CS models, the SM mid-mounted mower decks, turn the CS into a dedicated mowing machine. More information about the mowers can be found on page 50.



**5 YEAR'S WARRANTY
(3,000 HOURS)
POWERTRAIN WARRANTY
COMMERCIAL &
PRIVATE USE**

KIOTI

CX Series



"I can rely on the little tractor, it's easy to use, convenient and meets all my needs!"

Versatile Compact Tractor

CX Series (25 hp)

- Environmentally friendly.
- Powerful diesel engine.
- Two-stage HST gearbox.
- Four-wheel drive.
- Folding ROPS frame or cabin.
- Front linkage (Optional).
- Front PTO (Optional).
- Four-way control lever.
- Power steering.
- Three-point with position control.
- Generous ground clearance.
- Illuminated dashboard.
- Compact design.
- One-piece bonnet.



To run my maintenance business, I was looking for a compact tractor that would support my work in both summer and winter. The CX2510's size is ideal for my operations, its ability to operate many attachments and the affordable price were the deciding factors. I use a 1.40m wide mulching mower on the front to work on sports fields and larger meadows quickly and without stress. In winter, a snow plough and a spreader at the rear are used to clear the snow. The narrow dimensions and the exceptionally high manoeuvrability of the tractor are ideal for driving on all roads. I can rely on the small tractor, it is easy to use, comfortable and meets all my needs!

Malte Müller, Hausmeisterservice HTN, Suderburg

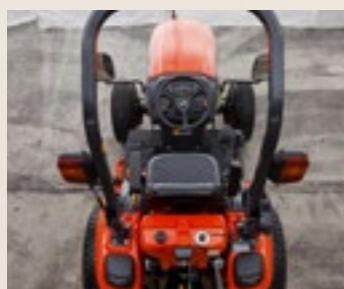

COMPACT DESIGN

The compact overall width combines with the tight turning circle, making the CX highly manoeuvrable, especially in tight spaces.



FOLDING ROPS SAFETY FRAME

The ROPS safety frame on open platform models protects the operator, but can be easily folded down when required.



ONE-PIECE BONNET

The one-piece bonnet opens upwards, providing good access to key maintenance points.



ENGINE

With the 1.6 litre diesel engine, the CX series is well suited for private and commercial uses.



HYDROSTATIC TRANSMISSION (HST)

The two-stage HST transmission is easily controlled via the twin pedals, engaging forward or reverse drive at the press of a foot.



POWER AND USB PORTS (ROPS)

Basic equipment for ROPS models: on-board 12 volt socket and double USB plug, enabling convenient powering and charging of electronic devices.



FRONT LINKAGE & PTO (Matev)

The CX2510 can be equipped with a front linkage and PTO, enabling the operation of front mounted equipment, boosting the tractor's capabilities.



FRONT MUDGUARDS

The front mudguards for the CX2510 turn with the front wheels, protecting the platform or cab windows from mud and water splashes.



CX Series



Model		CX2510-EU Roll bar	CX2510H-EU Roll bar	CX2510CH-EU Cabin
Motor				
Manufacturer		KIOTI	KIOTI	KIOTI
Control		Mechanical	Mechanical	Mechanical
Emissions tier		5	5	5
Maximum power (ECE-R120)	hp (kW)	24.8 (18.3)	24.8 (18.3)	24.8 (18.3)
Number of cylinders		3	3	3
Engine displacement	cc	1,647	1,647	1,647
Rated speed	rpm	2,600	2,600	2,600
Turbocharger		No	No	No
Fuel tank	l	25	25	25
Power-train				
Transmission		Mechanical gearbox	HST - Hydrostatic	HST - Hydrostatic
Number of gears or HST ranges		6F x 2R	2 ranges	2 ranges
Shuttle Type		-	-	-
Maximum speed (forward)	km/h	1.2-19.07	0-21.7	0-21.7
Four-wheel drive		Std.	Std.	Std.
Differential lock		Std. (rear axle)	Std. (rear axle)	Std. (rear axle)
Steering type		Hydr. power steering	Hydr. power steering	Hydr. power steering
PTO				
Rear PTO	rpm	540	540	540
Rated PTO power	hp	22.6	24.5	24.5
Rear PTO clutch		Foot clutch	Foot clutch	Foot clutch
Mid PTO	rpm	Opt.	Opt.	Opt.
		2,000	2,000	2,000
Front PTO (from intermediate axles)	rpm	Opt.	Opt.	Opt.
		2,000	2,000	2,000
Front PTO (by engine)	rpm	Opt.	Opt.	Opt.
		1,000	1,000	1,000
Hydraulics				
Number of double-acting spools at the rear		1 (Std.)	1 (Std.)	1 (Std.)
Four-way cross control lever		Std.	Std.	Std.
Number of mid double-acting spools		2	2	2
Pump power (work / steering)	l/min	42.9 (26 / 16.9)	42.9 (26 / 16.9)	42.9 (26 / 16.9)
Pressure	bar	160	160	160
Three-point linkage (rear)				
Regulation		Position control	Position control	Position control
Category		Cat 1	Cat 1	Cat 1
Maximum lifting capacity	kg	841	841	841
Lifting capacity at the coupling point (entire stroke)	kg	739	739	739
Lifting capacity 610mm behind coupling point (entire stroke)	kg	546	546	546
Three-point linkage (front)				
Available		Opt.	Opt.	Opt.
Category		Cat 0	Cat 0	Cat 0
Dimensions				
Total length (incl. three-point linkage)	mm	2,790	2,790	2,790
Width	mm	1,300 (turf tyres)	1,300 (turf tyres)	1,300 (turf tyres)
Total height (roll bar)	mm	2,288 (turf tyres)	2,288 (turf tyres)	-
Total height (cabin)	mm	-	-	2,170 (turf tyres)
Wheelbase	mm	1,520	1,520	1,520
Min. ground clearance	mm	180 (turf tyres)	180 (turf tyres)	180 (turf tyres)
Weight (roll bar)	kg	1,047	1,047	-
Weight (cabin)	kg	-	-	1,272
Permissible total weight	kg	1,870	2,130	2,130
Ab. Front axle load (max.)	kg	1,150	1,150	1,150
Ab. Rear axle load (max.)	kg	1,350	1,350	1,350
Towing capacity				
B1 - un-braked	kg	300	300	300
B2 - Overrun braked	kg	2,000	2,000	2,000
Extras				
Air conditioning		-	-	Std.
Swivel steering column		Std.	Std.	Std.
Cruise Control		Std.	Std.	Std.
HST Link (HST / engine speed coupling)		-	Std.	Std.
Stationary PTO operation		Std.	Std.	Std.



FACTORY CABIN

The high-quality, low-noise factory cab is fully integrated and offers a generous amount of space with great all-round visibility and easy entry.



AIR CONDITIONING

Comfortable in summer as well as in winter: the CX2510 cabin has air conditioning as standard, along with heated rear window and rear wiper.



POWER STEERING

The hydrostatic power steering, and the narrow turning radius allows effortless manoeuvrability. The steering wheel can be adjusted to suit every driver.



CRUISE CONTROL

The electrically switch-able cruise control allows the driving speed to be fixed at the touch of a button.



HST-LINK (OPTION H, STANDARD CH)

The HST-Link couples the HST accelerator pedal to the engine speed, meaning the further the pedal is pressed, the faster the ground speed. HST-Link can be switched off as required.



STATIONARY PTO SHAFT

The PTO can be operated without the driver in the seat simply by selecting S-PTO (e.g. for chopping logs).



FRONT LOADER CONTROL LEVER

The CS2520 is equipped with a four-way control lever for the comfortable operation of a front loader or other ancillary equipment.



USB/12V & AUX INPUT

With the 12V or USB plug, electrical devices can be charged. Via the AUX input, music can be played via the optionally available radio.



**5 YEAR'S WARRANTY
(3,000 HOURS)
POWERTRAIN WARRANTY
COMMERCIAL &
PRIVATE USE**

KIOTI

CK Series



"As an experienced riding arena attendant, I appreciate the advantages of the KIOTI CK3510"

Multi-Purpose Compact Tractor

CK Series (25–50 hp)

- Environmentally friendly engine.
- Manual transmission.
- HST hydrostat transmission.
- Cruise control (optional).
- HST-Link (std except CK2630).
- Front linkage (Optional).
- Front PTO (Optional).
- Generous ground clearance.
- Four-way front loader lever.
- Swivel steering column.
- Air conditioning.
- Rear window with wiper and heater (opt).
- High-quality comfort seat.
- One-piece bonnet.



We decided to get a new compact tractor for the maintenance of our tournament and riding arenas. I didn't know the KIOTI brand at first, after researching I was reassured to discover that it was a South Korean brand. The cliché that all machines from Asia are inferior certainly does not apply to KIOTI. We use a mower that is slightly oversized for this tractor for turf maintenance, and the CK3510 can easily handle it. As an experienced riding arena attendant, I very quickly learned to appreciate the advantages of the KIOTI: very manoeuvrable, the hydrostat works perfectly and the rear hydraulics are incredibly fast. I have not experienced such agility with other tractors. Ergonomics have also been considered: getting on is easy, there is space and the controls are always within easy reach. KIOTI's CK3510 meets our needs with ease.

Hartmut Cordes, Elmloher Reitertage, Geestland



CK Series



FOLDING MID ROPS SAFETY FRAME (OPTIONAL)

The ROPS safety frame protects the operator, but can be easily folded down when required. The frames on the smaller models are mid-mounted with rear mounted for the others.



MAXIMUM FLEXIBILITY

With front, middle and rear mounting options, a variety of attachments can be used.



FRONT AXLE

The heavy duty front axle provides excellent ground clearance and a tight turning circle, making the CK highly manoeuvrable.



ILLUMINATED DASHBOARD

The illuminated dashboard is easy to read in bright daylight or at night.



KIOTI DIESEL ENGINE

The Stage V engines with Common Rail Diesel Injection (CRDI) technology meets current environmental standards, they're also powerful, fuel-efficient and smooth running.



FRONT LINKAGE & PTO (MATEV)

The front linkage and PTO increase the versatility of the CK tractor by enabling the operation of front mounted equipment.



FRONT MUDGUARDS

Front mudguards protect the platform or windscreen from mud and water splashes. The CK is available with rigid or following options.



FRONT LOADER CONTROL LEVER

The CK is equipped with a four-way control lever for the comfortable operation of a front loader or other ancillary equipment.



FACTORY CABIN

The large panoramic windows of the 4-post cab offer the best possible all-round visibility. Wide-opening doors and high-quality workmanship provide a great working environment.



WINDSCREEN WIPERS & HEATING

The windscreen wipers (rear optional), and windscreen heater, ensure good visibility in all weathers, all year round.



AIR CONDITIONING

Whether summer or winter, with the standard air conditioning system, the cabin temperature is always comfortable, rear window heater.



SPRUNG SEAT

The spring-loaded fabric seat, with armrests, offers the driver a high level of seating comfort throughout the day.



ADJUSTABLE STEERING WHEEL

All models of the CK series have a swivelling steering column, adjustable to suit operator's driving position.



INDEPENDENT PTO CONNECTION

The rear PTO of the CK series can be easily activated via the rotary knob, and switched on either manually or via Auto PTO.



PTO CONTROL

The switches can be used to operate the stationary PTO (S-PTO), the automatic PTO circuit (Auto PTO) and the speed storage for the engine or PTO (PTO Cruise).



ONE-PIECE BONNET

The one-piece bonnet is easy to open and allows quick access to the machine's maintenance points.



“It’s amazing: The machine has been outside in the wind, rain and snow for over 10 years, the engine always starts, and I only had to top up the oil occasionally.”

OLD BUT GOLD

A CK35 has been supporting us at work on our stud farm for over 10 years. We use the little red Kioti to re-level our riding arena twice a day with a riding arena leveller and a roller. The CK35 is a perfect and reliable help. Operation is child’s play, the dashboard is laid out logically, it takes less than three minutes to instruct new drivers and we have a lot of fun driving around with the tractor. It’s amazing: The machine has been outside in the wind, rain and snow for over 10 years, the engine always starts without any problems, and I only had to top up the oil occasionally. After more than 3,000 operating hours, we are very satisfied with the machine. It is ideal for our purposes and I can recommend Kioti tractors to everyone.

*Joachim Schiedel,
Gestüt am Helkenteich*

Model		CK2630D-EU	CK2630H-EU	CK3530H-EU	CK4030H-EU	CK5030H-EU	CK2630CH-EU	CK3530CH-EU	CK4030CH-EU	CK5030CH-EU
		Roll bar (mid-mounted)	Roll bar	Roll bar	Roll bar	Roll bar	Cabin	Cabin	Cabin	Cabin
Motor										
Manufacturer		KIOTI	KIOTI	KIOTI	KIOTI	KIOTI	KIOTI	KIOTI	KIOTI	KIOTI
Control		Mechanical	Mechanical	Electronic (CRDI)	Electronic (CRDI)	Electronic (CRDI)	Mechanical	Electronic (CRDI)	Electronic (CRDI)	Electronic (CRDI)
Emissions tier		5	5	5	5	5	5	5	5	5
Maximum power (ECE-R120)	hp (kW)	24.8 (18.3)	24.8 (18.3)	35.3 (26)	40.1 (29.5)	50.9 (37.5)	24.8 (18.3)	35.3 (26)	40.1 (29.5)	50.9 (37.5)
Number of cylinders		3	3	3	3	3	3	3	3	3
Engine displacement	cc	1,647	1,647	1,826	1,826	1,826	1,647	1,826	1,826	1,826
Rated speed	rpm	2,400	2,400	2,600	2,600	2,600	2,400	2,600	2,600	2,600
Turbocharger		No	No	No	No	Yes	No	No	No	Yes
Fuel tank	l	34	34	34	34	34	34	34	34	34
Power-train										
Transmission		Mechanical gearbox	HST - hydrostatic	HST - hydrostatic	HST - hydrostatic	HST - hydrostatic	HST - hydrostatic	HST - hydrostatic	HST - hydrostatic	HST - hydrostatic
Number of gears or HST ranges		12x12 F/R	3 ranges	3 ranges	3 ranges	3 ranges	3 ranges	3 ranges	3 ranges	3 ranges
Shuttle Type		Synchro-shuttle	-	-	-	-	-	-	-	-
Maximum speed (forward)	km/h	1.3-17.5	0-27.8	0-27.8	0-27.8	0-27.8	0-27.8	0-27.8	0-27.8	0-27.8
Four-wheel drive		Std.	Std.	Std.	Std.	Std.	Std.	Std.	Std.	Std.
Differential lock		Std. (rear axle)	Std. (rear axle)	Std. (rear axle)	Std. (rear axle)	Std. (rear axle)	Std. (rear axle)	Std. (rear axle)	Std. (rear axle)	Std. (rear axle)
Steering type		Hydr. power steering	Hydr. power steering	Hydr. power steering	Hydr. power steering	Hydr. power steering	Hydr. power steering	Hydr. power steering	Hydr. power steering	Hydr. power steering
PTO										
Rear PTO	rpm	540/540E	540/540E	540/540E	540/540E	540/540E	540/540E	540/540E	540/540E	540/540E
Rated PTO power	hp	20.3	20.3	29.2	32.7	45.3	20.3	29.2	32.7	45.3
Rear PTO clutch		Elec- hydr. engagement	Elec- hydr. engagement	Elec- hydr. engagement	Elec- hydr. engagement	Elec- hydr. engagement	Elec- hydr. engagement	Elec- hydr. engagement	Elec- hydr. engagement	Elec- hydr. engagement
Mid PTO	rpm	Opt. 2,000	Opt. 2,000	Opt. 2,000	Opt. 2,000	Opt. 2,000	Opt. 2,000	Opt. 2,000	Opt. 2,000	Opt. 2,000
Front PTO (from intermediate axles)	rpm	Opt. 2,000	Opt. 2,000	Opt. 2,000	Opt. 2,000	Opt. 2,000	Opt. 2,000	Opt. 2,000	Opt. 2,000	Opt. 2,000
Front PTO (by engine)	rpm	Opt. 1,000	Opt. 1,000	Opt. 1,000	Opt. 1,000	Opt. 1,000	Opt. 1,000	Opt. 1,000	Opt. 1,000	Opt. 1,000
Hydraulics										
Number of rear double-acting spools		1 (Std.) (1 Opt.)	1 (Std.) (1 Opt.)	1 (Std.) (1 Opt.)	2 (Std.)	2 (Std.)	2 (Std.)	2 (Std.)	2 (Std.)	2 (Std.)
Four-way cross control lever		Opt.	Opt.	Std.	Std.	Std.	Std.	Std.	Std.	Std.
Number of mid double-acting spools		2	2	2	2	2	2	2	2	2
Pump power (work / steering)	l/min	39.6 (24 / 15.6)	39.6 (24 / 15.6)	42.9 (26 / 16.9)	42.9 (26 / 16.9)	42.9 (26 / 16.9)	42.9 (26 / 16.9)	42.9 (26 / 16.9)	42.9 (26 / 16.9)	42.9 (26 / 16.9)
Pressure	bar	185	185	185	185	185	185	185	185	185
Three-point linkage (rear)										
Regulation		Position / draft / combination	Position / draft / combination	Position control	Position control	Position control	Position / draft / combination	Position control	Position control	Position control
Category		Cat 1	Cat 1	Cat 1	Cat 1	Cat 1	Cat 1	Cat 1	Cat 1	Cat 1
Maximum lifting capacity	kg	1,130	1,130	1,130	1,130	1,130	1,130	1,130	1,130	1,130
Lifting capacity at the coupling point (entire stroke)	kg	1,030	1,030	1,030	1,030	1,030	1,030	1,030	1,030	1,030
Lifting capacity 610mm behind coupling point (entire stroke)	kg	740	740	740	740	740	740	740	740	740
Three-point linkage (front)										
Available		Opt.	Opt.	Opt.	Opt.	Opt.	Opt.	Opt.	Opt.	Opt.
Category		Cat 0 / Cat 1	Cat 0 / Cat 1	Cat 0 / Cat 1	Cat 0 / Cat 1	Cat 0 / Cat 1	Cat 0 / Cat 1	Cat 0 / Cat 1	Cat 0 / Cat 1	Cat 0 / Cat 1
Dimensions										
Total length (incl. three-point linkage)	mm	3,063	3,063	3,063	3,063	3,063	3,063	3,063	3,063	3,063
Width	mm	1,543 (turf tyres)	1,543 (turf tyres)	1,543 (turf tyres)	1,543 (turf tyres)	1,543 (turf tyres)	1,543 (turf tyres)	1,543 (turf tyres)	1,543 (turf tyres)	1,543 (turf tyres)
Total height (roll bar)	mm	2,099 (turf tyres)	2,488 (turf tyres)	2,488 (turf tyres)	2,488 (turf tyres)	2,488 (turf tyres)	-	-	-	-
Total height (cabin)	mm	-	-	-	-	-	2,340 (turf tyres)	2,340 (turf tyres)	2,340 (turf tyres)	2,340 (turf tyres)
Wheelbase	mm	1,670	1,670	1,670	1,670	1,670	1,670	1,670	1,670	1,670
Min. ground clearance	mm	319 (turf tyres)	319 (turf tyres)	319 (turf tyres)	319 (turf tyres)	319 (turf tyres)	319 (turf tyres)	319 (turf tyres)	319 (turf tyres)	319 (turf tyres)
Weight (roll bar)	kg	1,343	1,360	1,360	1,360	1,360	-	-	-	-
Weight (cabin)	kg	-	-	-	-	-	1,578	1,578	1,578	1,578
Permissible total weight	kg	2,695	2,625	2,625	2,625	2,625	2,800	2,800	2,800	2,800
Ab. Front axle load (max.)	kg	1,000	1,000	1,000	1,000	1,000	1,000	1,000	1,000	1,000
Ab. Rear axle load (max.)	kg	1,800	1,800	1,800	1,800	1,800	1,800	1,800	1,800	1,800
Towing capacity										
B1 - unbraked	kg	650	650	720	720	720	720	720	720	720
B2 - Overrun braked	kg	3,300	3,300	3,300	3,300	3,300	3,300	3,300	3,300	3,300
Extras										
Air conditioning		-	-	-	-	-	Std.	Std.	Std.	Std.
Swivel steering column		Std.	Std.	Std.	Std.	Std.	Std.	Std.	Std.	Std.
Cruise Control		-	Std.	Std.	Std.	Std.	Std.	Std.	Std.	Std.
HST Link (HST / engine speed coupling)		-	Std.	Std.	Std.	Std.	Std.	Std.	Std.	Std.
Stationary PTO operation		Std.	Std.	Std.	Std.	Std.	Std.	Std.	Std.	Std.
Automatic PTO control with rear linkage		Std.	Std.	Std.	Std.	Std.	Std.	Std.	Std.	Std.
Cruise PTO (hand throttle)		-	-	Std.	Std.	Std.	Std.	Std.	Std.	Std.



**5 YEAR'S WARRANTY
(3,000 HOURS)
POWERTRAIN WARRANTY
COMMERCIAL &
PRIVATE USE**

KIOTI

DK Series



“The DK6010 always makes a very good impression. We are happy to have the KIOTI on our team.”

Compact Tractor for Larger Operations

DK Series (45–58 hp)

- Environmentally friendly diesel engine.
- Manual transmission, with creeper gears .
- Three-speed HST gearbox with double pedal.
- Cruise control (Optional).
- HST-Link (Optional).
- Automatic PTO switch
- Front linkage (Optional).
- Front PTO (Optional).
- Generous ground clearance.
- Air conditioning.
- Front loader control lever.
- Swivel steering column.
- Rear window and heater.
- High-quality comfort seat.
- One-piece bonnet.



The DK6010 with its HST gearbox has been in use at our construction yard to cut overhanging vegetation on paths and roads since January 2021. The high mounted PTO shaft is a great advantage, giving us ample ground clearance with the attached front hedge cutter. At the rear we use a flail mower, which the DK gets along with very well. In winter service, the KIOTI is equipped with a snow plough, to ensure paths are kept clear. The cabin is ergonomically well thought out, the seat suspension is very comfortable, the driving is 1A and if you have experience operating tractors, you feel right at home in the KIOTI. Compared with other manufacturers, KIOTI tractor seems more stable. The lower three-point linkage is massive and the front axle is very strong for the engine power - put simply, it always makes a very good impression. We are happy to have added the KIOTI in our team.

Björn Hennings, Bauhof Stadt Brunsbüttel



HYDROSTATIC GEARBOX

The powerful HST hydrostat transmission makes the tractor highly manoeuvrable and easy to operate thanks to the twin-pedal control.

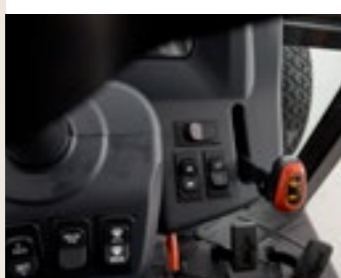

CRUISE CONTROL

The electrically switch-able cruise control allows the driving speed to be fixed at the touch of a button.



GEARBOX: MECHANICAL OR HYDROSTAT (HST)

Depending on the model, a synchronised reversible gearbox or a three-stage hydrostat transmission is available.



CLUTCH BUTTON ON THE GEAR LEVER

A simple alternative to the clutch pedal, the clutch button can be found on the hydro reversing lever, helping simplify the operation of the tractor.



PTO SWITCH

The independent, electro hydraulic PTO can be conveniently activated and deactivated via the switch in the side console.



AUTOMATIC PTO

The activated rear PTO can be coupled to the rear 3-point linkage via the Auto PTO function and can be automatically switched off or on via lifting.



PTO CRUISE

For CRDI models, the engine speed can be stored, so it can be reset after turning and manoeuvring, useful when operating PTO driven implements.



REAR HYDRAULICS

The DK series come as standard, with two double-acting services at the rear, enabling the operation of hydraulic attachments.



AIR CONDITIONING

The factory fit cabin is equipped with air conditioning. The air recirculation vents prevent external odours entering and helps cool the temperature faster.



SPACIOUS STORAGE AREA

The storage area is located directly next to the 12V power connection and allows easy charging of personal devices.



ILLUMINATED DASHBOARD

The illuminated dashboard is easy to read in all conditions and always provides an overview of the tractor's status.



ADJUSTABLE STEERING WHEEL

Whether with or without cab, the swivelling steering column in the DK series can be adapted to suit the driver.



COMMON RAIL DIESEL TECHNOLOGY

The lively Stage V engines with Common Rail Diesel Injection (CRDI) technology not only meet the latest environmental standards, but are also fuel-efficient and smooth running.



TOOLBOX

The practical toolbox offers space to keep essential tools close by and secure, keeping the cabin floor free from clutter.



FRONT LINKAGE AND PTO

The front linkage and PTO make the DK series highly versatile, for example by enabling a snow blower to be used in winter, or sweeping brush used in summer.



CLEVIS DRAW BAR

A height adjustable clevis type draw bar can be installed to ease the hitching and unhitching of equipment.



"I assume that the KIOTI EX50 will run forever."

OLD BUT GOLD

The EX50 from KIOTI was purchased in 2011 by Bremer Strassenbahn AG for the maintenance of the accompanying greenery, the railway facilities and tracks and has been doing its job since then without trouble. The powerful tractor is wonderfully clear with the flail mower mounted on the rear, which can be extended widely and clears away a good deal. In winter service we use a salt spreader and a snow plough. Since we drive in normal traffic, the manoeuvrability and the compact design is very helpful: I can drive on all roads and paths and don't disturb the flow of traffic. I sit on the machine for up to 8 hours a day and am very impressed with the cabin. The seat is comfortable and has excellent suspension, the controls are logically arranged and easily accessible. Maintenance is easy, the price-performance ratio is unbeatable compared to other brands, and the robust construction is also convincing. After all these years, nothing wobbles or rattles. I assume that the KIOTI EX50 will run forever.

Marc Hanussek, BSAG,
Bremer Straßenbahn AG

Model		DK4520H-EU	DK5020H-EU	DK6020H-EU	DK6020H-EU	DK4520C-EU	DK4520CH-EU	DK5020C-EU	DK5020CH-EU	DK6020C-EU	DK6020CH-EU
		Roll-bar	Roll-bar	Roll-bar	Roll-bar	Cabin	Cabin	Cabin	Cabin	Cabin	Cabin
Motor											
Manufacturer		KIOTI	KIOTI	KIOTI	KIOTI	KIOTI	KIOTI	KIOTI	KIOTI	KIOTI	KIOTI
Control		Electronic (CRDI)	Electronic (CRDI)	Electr (CRDI)	Electronic (CRDI)	Electronic (CRDI)	Electronic (CRDI)	Electronic (CRDI)	Electronic (CRDI)	Electronic (CRDI)	Electronic (CRDI)
Emissions tier		5	5	5	5	5	5	5	5	5	5
Maximum power (ECE-R120)	hp (kW)	45.5 (33.5)	51.0 (37.5)	58.5 (43)	58.5 (43)	45.5 (33.5)	45.5 (33.5)	51.0 (37.5)	51.0 (37.5)	58.5 (43)	58.5 (43)
Number of cylinders		3	3	3	3	3	3	3	3	3	3
Engine displacement	cc	1,826	1,826	1,826	1,826	1,826	1,826	1,826	1,826	1,826	1,826
Rated speed	rpm	2,600	2,600	2,600	2,600	2,600	2,600	2,600	2,600	2,600	2,600
Turbocharger		Yes	Yes	Yes	Yes	Yes	Yes	Yes	Yes	Yes	Yes
Fuel tank	l	48	48	48	48	48	48	48	48	48	48
Power-train											
Transmission		HST - hydrostatic	Mechanical gearbox	Mech gearbox	HST - hydrostatic	Mechanical gearbox	HST - hydrostatic	Mechanical gearbox	HST - hydrostatic	Mechanical gearbox	HST - hydrostatic
Number of gears or HST ranges		3 ranges	16X16 F/R	16X16 F/R	3 ranges	16X16 F/R	3 ranges	16X16 F/R	3 ranges	16X16 F/R	3 ranges
Shuttle Type		-	Hydro-shuttle	Hydro - shuttle	-	Synchro-shuttle	-	Synchro-shuttle	-	Synchro-shuttle	-
Creep gear		-	Std.	Std.	-	Std.	-	Std.	-	Std.	-
Maximum speed (forward)	km/h	0 - 30.8	0.3- 33.0	0.3- 33.0	0 - 30.8	0.3- 33.0	0 - 30.8	0.3- 33.0	0 - 30.8	0.3- 33.0	0 - 30.8
Four-wheel drive		Std.	Std.	Std.	Std.	Std.	Std.	Std.	Std.	Std.	Std.
Differential lock		Std. (rear axle)	Std. (rear axle)	Std. (rear axle)	Std. (rear axle)	Std. (rear axle)	Std. (rear axle)	Std. (rear axle)	Std. (rear axle)	Std. (rear axle)	Std. (rear axle)
Steering type		Hydr. power steering	Hydr. power steering	Hydr. pow. steering	Hydr. power steering	Hydr. power steering	Hydr. power steering	Hydr. power steering	Hydr. power steering	Hydr. power steering	Hydr. power steering
PTO											
Rear PTO	rpm	540	540/540E	540/540E	540	540/540E	540	540/540E	540	540/540E	540
Rated PTO power	hp	37.0	42.4	50.8	47.6	38.1	37.0	42.4	42.4	50.8	47.6
Rear PTO clutch		Elec-hydr. engagement	Elec-hydr. engagement	El. hydr. engagement	Elec-hydr. engagement	Elec-hydr. engagement	Elec-hydr. engagement	Elec-hydr. engagement	Elec-hydr. engagement	Elec-hydr. engagement	Elec-hydr. engagement
Front PTO (from intermediate axles)	rpm	Opt 2,000	- -	- -	Opt 2,000	- -	Opt 2,000	- -	Opt 2,000	- -	Opt 2,000
Front PTO (by engine)	rpm	Opt 1,000	Opt 1,000	Opt 1,000	Opt 1,000	Opt 1,000	Opt 1,000	Opt 1,000	Opt 1,000	Opt 1,000	Opt 1,000
Hydraulics											
Number of rear double-acting spools		2 (Std.)	2 (Std.)	2 (Std.)	2 (Std.)	2 (Std.)	2 (Std.)	2 (Std.)	2 (Std.)	2 (Std.)	2 (Std.)
Four-way cross control lever		front loader	front loader	F loader	Front loader	Std.	Std.	Std.	Std.	Std.	Std.
Number of mid double-acting spools		2	2	2	2	2	2	2	2	2	2
Pump power (work / steering)	l/min	62.4 (36.4 / 26.0)	55.1 (36.4 / 18.7)	62.4 (36.4 / 26)	62.4 (36.4 / 26)	62.4 (36.4 / 26)	62.4 (36.4 / 26)	62.4 (36.4 / 26)	62.4 (36.4 / 26)	62.4 (36.4 / 26)	62.4 (36.4 / 26)
Pressure	bar	195	195	195	195	195	195	195	195	195	195
Three-point linkage (rear)											
Regulation		Position control	Position / draft / combination	Position / draft / combi	Position control	Position / draft / combination	Position control	Position / draft / combination	Position control	Position / draft / combination	Position control
Category		Cat 1 (Cat 2 Opt.)	Cat 1 (Cat 2 Opt.)	Cat 1 (Cat 2 Opt.)	Cat 1 (Cat 2 Opt.)	Cat 1 (Cat 2 Opt.)	Cat 1 (Cat 2 Opt.)	Cat 1 (Cat 2 Opt.)	Cat 1 (Cat 2 Opt.)	Cat 1 (Cat 2 Opt.)	Cat 1 (Cat 2 Opt.)
Maximum lifting capacity	kg	1,717	1,717	1,717	1,717	1,717	1,717	1,717	1,717	1,717	1,717
Lifting capacity at the coupling point (entire stroke)	kg	1,417	1,417	1,417	1,417	1,417	1,417	1,417	1,417	1,417	1,417
Lifting capacity 610mm behind coupling point (entire stroke)	kg	1,467	1,467	1,467	1,467	1,467	1,467	1,467	1,467	1,467	1,467
Three-point linkage (front)											
Available		Opt.	Opt.	Opt.	Opt.	Opt.	Opt.	Opt.	Opt.	Opt.	Opt.
Category		Cat 1	Cat 1	Cat 1	Cat 1	Cat 1	Cat 1	Cat 1	Cat 1	Cat 1	Cat 1
Dimensions											
Total length (incl. three-point lift)	mm	3,310	3,288	3,310	3,310	3,310	3,310	3,310	3,310	3,310	3,310
Width	mm	1,503 (Ag tyres)	1,503 (Ag tyres)	1,503 (Ag tyres)	1,503 (Ag tyres)	1,503 (Ag tyres)	1,503 (Ag tyres)	1,503 (Ag tyres)	1,503 (Ag tyres)	1,503 (Ag tyres)	1,503 (Ag tyres)
Total height (roll bar)	mm	2,405 (Ag tyres)	2,405 (Ag tyres)	2,405 (Ag tyres)	2,405 (Ag tyres)	-	-	-	-	-	-
Total height (cabin)	mm	-	-	-	-	2,363 (Ag tyres)	2,363 (Ag tyres)	2,363 (Ag tyres)	2,363 (Ag tyres)	2,363 (Ag tyres)	2,363 (Ag tyres)
Wheelbase	mm	1,810	1,810	1,810	1,810	1,810	1,810	1,810	1,810	1,810	1,810
Min. ground clearance	mm	362 (Ag tyres)	362 (Ag tyres)	362 (Ag tyres)	362 (Ag tyres)	362 (Ag tyres)	362 (Ag tyres)	362 (Ag tyres)	362 (Ag tyres)	362 (Ag tyres)	362 (Ag tyres)
Weight (roll bar)	kg	1,598	1,610	1,610	1,598	-	-	-	-	-	-
Weight (cabin)	kg	-	-	-	-	1,848	1,887	1,848	1,887	1,848	1,887
Permissible total weight	kg	2,885	2,885	3,447	3,447	3,447	2,885	3,447	3,447	3,447	3,447
Ab. Front axle load (max.)	kg	1,750	1,750	1,750	1,750	1,750	1,750	1,750	1,750	1,750	1,750
Ab. Rear axle load (max.)	kg	1,950	1,950	1,950	1,950	1,950	1,950	1,950	1,950	1,950	1,950
Towing capacity											
B1 - unbraked	kg	630	2,100	2,100	630	2,100	630	2,100	630	2,100	630
B2 - Overrun braked	kg	5,500	5,500	5,500	5,500	5,500	5,500	5,500	5,500	5,500	5,500
Extras											
Air conditioning		-	-	-	-	Std.	Std.	Std.	Std.	Std.	Std.
Swivel steering column		Std.	Std.	Std.	Std.	Std.	Std.	Std.	Std.	Std.	Std.
Cruise Control		Opt.	-	-	Opt.	-	Std.	-	Std.	-	Std.
HST Link (HST / engine speed coupling)		Opt.	-	-	Opt.	-	Std.	-	Std.	-	Std.
Stationary PTO operation		Std.	Std.	Std.	Std.	Std.	Std.	Std.	Std.	Std.	Std.
Automatic PTO control with rear linkage		Std.	Std.	Std.	Std.	Std.	Std.	Std.	Std.	Std.	Std.
Cruise PTO (hand throttle)		Std.	Std.	Std.	Std.	Std.	Std.	Std.	Std.	Std.	Std.
Clutch button on gear shifter		-	Std.	Std.	-	-	-	-	-	-	-



**5 YEAR'S WARRANTY
(3,000 HOURS)
POWERTRAIN WARRANTY
COMMERCIAL &
PRIVATE USE**

KIOTI

A Multi-purpose Tractor

RX Series (73 hp)

- Stage V powerful CRDI diesel engine.
- Ergonomic control levers.
- Electro-hydraulic reversible switch.
- Swivel steering column.
- Crawler gears.
- LCD dashboard.
- Automatic PTO switch.
- Rear window wipers.
- Cross lever control unit .
- Air-sprung driver's seat.
- Air conditioning / heating.
- One-piece bonnet.

RX Series

Model	RX7330P-EU	
	Roll-bar	Cabin
Motor		
Manufacturer	KIOTI	
Control	Electronic (CRDI)	
Emissions tier	5	
Maximum power (ECE-R120)	hp (kW)	74.1 (54.5)
Number of cylinders	4	
Engine displacement	cc	2,435
Rated speed	rpm	2,600
Turbocharger	Yes	
Fuel tank	l	85
Power-train		
Transmission	Mechanical gearbox	
Number of gears or HST ranges	24/24 F/R	
Shuttle Type	Power shuttle	
Creeper gear	Std.	
Maximum speed (forward)	km/h	0.17 - 37.86
Four-wheel drive	Std.	
Differential lock	Std. (rear axle)	
Steering type	Hydr. power steering	
PTO		
Rear PTO	rpm	540/540E
Rated PTO power	hp	62.9
Rear PTO clutch	Elec-hydr. engagement	
Front PTO (by engine)	Opt.	
	rpm	1,000
Hydraulics		
Number of double-acting spools at the rear	1 (Std.) 1 (opt.)	
Four-way cross control lever	Std.	
Number of mid double-acting spools	2	
Pump power (work / steering)	l/min	72.8 (41.6 / 31.2)
Pressure	bar	190
Three-point linkage (rear)		
Regulation	Position / draft / combination	
Category	Cat 2	
Maximum lifting capacity	kg	3,075
Lifting capacity at the coupling point (entire stroke)	kg	2,935
Lifting capacity 610mm behind coupling point (entire stroke)	kg	2,195
Three-point linkage (front)		
Available	Opt.	
Category	Cat 2	
Dimensions		
Total length (incl. three-point linkage)	mm	3,715
Width	mm	1,960 (ag tyres)
Total height (roll bar)	mm	2,819 (ag tyres)
Total height (cabin)	mm	-
Wheelbase	mm	2,130
Min. ground clearance	mm	433 (ag tyres)
Weight (roll bar)	2,540	
Weight (cabin)	kg	2,745
Permissible total weight	kg	4,450
Ab. Front axle load (max.)	kg	2,200
Ab. Rear axle load (max.)	kg	3,100
Towing capacity		
B1 - unbraked	kg	2,700
B2 - Overrun braked	kg	7,000
Extras		
Air conditioning	-	
Swivel steering column	Std.	
Air suspension driver's seat	Opt.	
Clutch button on gear shifter	-	

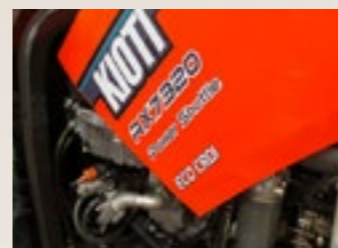

OPTIMISED POWER-TO-WEIGHT RATIO

Low ground pressure thanks to a high performance engine and low weight . Ideal for utility and agricultural operations.



CLEVIS DRAW BAR

A height adjustable clevis type draw bar can be installed to ease the hitching and unhitching of equipment.



AIR-SPRUNG DRIVER'S SEAT (OPTION)

The ergonomic, air-sprung seat ensures driver comfort on the road and across rough terrain.



MANUAL TRANSMISSION WITH POWER SHUTTLE

The Power shuttle enables a smooth change of direction. The gear lever button negates the need for manual operation of the clutch pedal.

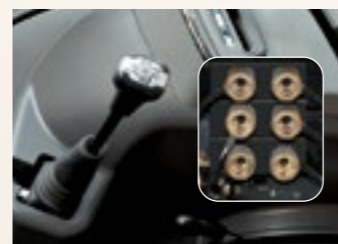

FRONT LOADER LEVER AND REAR HYDRAULICS

In addition to three double-acting rear spools, the front loader control lever is simple and convient to use.

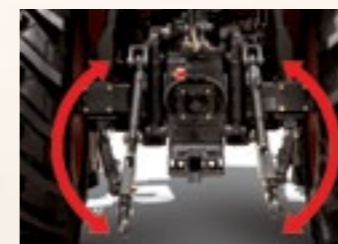

3-POINT LINKAGE

Two external hydraulic cylinders allow easy maintenance of the rear linkage and achieve a maximum lifting capacity of 3,075kg.



DRIVING SPEED

In addition to high power transmission, the efficient transmission of the RX also delivers a driving speed of 38 km/h during transport work.

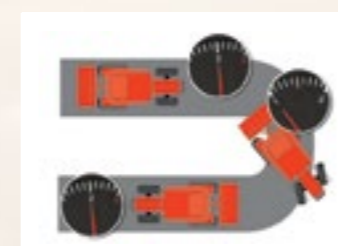

TURNING ASSISTANT

The Reversing assist lowers the engine speed when the steering angle is tight, improving cornering accuracy and safety.



**5 YEAR'S WARRANTY
(3,000 HOURS)
POWERTRAIN WARRANTY
COMMERCIAL &
PRIVATE USE**

KIOTI



The New Power House in the KIOTI-Team

HX Series (91-117 hp)

With Boost 100 – 127 hp

- 3.8l CRDI diesel engine.
- Boost for road and PTO work.
- Speed memory.
- Spacious 5-post cabin.
- Air seat with armrest controls
- Air conditioning / heating.
- Sunroof.
- Adjustable steering column.
- Comfortable passenger seat.
- Power shuttle gearbox.
- Creeper gears.
- Power switching stage.
- Clutch button.
- 3 PTO speeds.
- Auto. PTO switch.
- Front axle with LSD differential.



3,8L CRDI DIESEL ENGINE

The powerful Daedong CRDI engine has low fuel consumption and a boost function for transport and PTO work.



CLUTCH BUTTON ON GEAR SHIFT

The 32/32 Power Shuttle transmission has a powershift stage. The clutch button on the gear lever makes work easier, especially during transport.



FRONT AXLE WITH LSD DIFFERENTIAL

The robust Daedong front axle with lamellar locking differential (LSD) ensures maximum traction in all conditions.



REAR HYDRAULICS

3 double acting spools can be installed at the rear. The powerful CAT 2 rear lift has a lifting capacity of 4.4t.



SPACIOUS 5-POST CABIN

The spacious cabin provides a clear all-round view, air conditioning, many storage options and ergonomic controls.



AIR SPRING SEAT WITH CONTROL ARMREST

The air-sprung driver's seat with control armrest ensures relaxed working. The passenger seat with seat belt offers the passenger full safety.



ADJUSTABLE STEERING COLUMN

The swivel and telescopic steering column facilitates entry and exit and makes the working posture more ergonomic.



SUNROOF

The sunroof gives great visibility of the front loader. It can be darkened, and opened to provide additional fresh air.

HX Series

Model		HX9101PC Cabin	HX1001PC Cabin	HX1201PC Cabin
Motor				
Manufacturer		KIOTI	KIOTI	KIOTI
Control		Electronic (CRDI)	Electronic (CRDI)	Electronic (CRDI)
Emissions tier		5	5	5
Maximum power (ECE-R120) with boost	hp (kW)	91.2 (67.1) / 99.9 (73.5)	101.2 (74.5) / 111.5 (82.0)	116.8 (86.0) / 127.1 (93.5)
Number of cylinders		4	4	4
Engine displacement	cc	3,833	3,833	3,833
Rated speed	rpm	2,200	2,200	2,200
Turbocharger		Yes & inter-cooler	Yes & inter-cooler	Yes & inter-cooler
Fuel tank	l	180	180	180
Power-train				
Transmission		Mechanical gearbox	Mechanical gearbox	Mechanical gearbox
Number of gears or HST ranges		32x32 F/R	32x32 F/R	32x32 F/R
Shuttle Type		Power shuttle	Power shuttle	Power shuttle
Creeper gear		Std.	Std.	Std.
Power shift		Std.	Std.	Std.
Maximum speed (forward)	km/h	0.20 - 39.50	0.20 - 39.50	0.20 - 39.50
Four-wheel drive		Std.	Std.	Std.
Differential lock		Std.	Std.	Std.
Steering type		Hydr. power steering	Hydr. power steering	Hydr. power steering
PTO				
Rear PTO	rpm	540/540E/1,000	540/540E/1,000	540/540E/1,000
Rated PTO power	hp	78.8	81.5	100.6
Rear PTO clutch		Elec-hydr. engagement	Elec-hydr. engagement	Elec-hydr. engagement
Front PTO (by engine)		Opt.	Opt.	Opt.
	rrm	1,000	1,000	1,000
Hydraulics				
Number of double-acting spools at the rear		2 (Std.) 1 (Opt.)	2 (Std.) 1 (Opt.)	2 (Std.) 1 (Opt.)
Four-way cross control lever		Std.	Std.	Std.
Number of mid double-acting spools		2	2	2
Pump power (work / steering)	l/min	121.0 (74.8 / 46.2)	121.0 (74.8 / 46.2)	121.0 (74.8 / 46.2)
Pressure	bar	185	185	185
Three-point linkage (rear)				
Regulation		EHR	EHR	EHR
Category		Cat 2	Cat 2	Cat 2
Maximum lifting capacity	kg	4,410	4,410	4,410
Lifting capacity at the coupling point (entire stroke)	kg	3,665	3,665	3,665
Lifting capacity 610mm behind coupling point (entire stroke)	kg	3,630	3,630	3,630
Three-point linkage (front)				
Available		Opt.	Opt.	Opt.
Category		Cat 2	Cat 2	Cat 2
Dimensions				
Total length (incl. three-point linkage)	mm	4,398	4,398	4,398
Width	mm	2,126	2,126	2,126
Total height (cabin)	mm	2,820	2,820	2,820
Wheelbase	mm	2,410	2,410	2,410
Min. ground clearance	mm	459	459	459
Weight (cabin)	kg	4,428	4,428	4,428
Permissible total weight	kg	7,100	7,100	7,100
Ab. Front axle load (max.)	kg	3,200	3,200	3,200
Ab. Rear axle load (max.)	kg	4,270	4,270	4,270
Towing capacity				
B1 - unbraked	kg	3,500	3,500	3,500
B2 - Overrun braked	kg	8,000	8,000	8,000
B3 - Hydraulic braked	kg	-	-	-
B4 - Pneumatic braked	kg	On request	On request	On request
Extras				
Air conditioning		Std.	Std.	Std.
Swivel steering column		Std.	Std.	Std.
Air suspension driver's seat		Std.	Std.	Std.
Clutch button on gear shifter		Std.	Std.	Std.



2 YEARS' WARRANTY (Unlimited Hours)
KIOTI

"Being able to rely on such a handy and manouverable utility vehicle is great."

The Utility Vehicle for all Terrains and Jobs

K9 (25 hp)

- Powerful KIOTI diesel engine.
- Sporty design.
- Noise and vibration dampened.
- Robust CVT transmission.
- Independent double wishbones suspension.
- Illuminated dashboard.
- Swivel steering column.
- One-hand operation of the tailgate.
- Hydraulic system (Optional).
- Front linkage (Optional).
- High payload & ground clearance.



We have added a KIOTI K9 to our fleet work in our gardening and landscaping business. Mainly used in our tree nursery, we use our K9 for planting perennials, transporting materials and general transport. The hydraulically tipping loading area is great, and pulls a trailer without any problems, this makes our work a lot easier. I also regularly use the speedster privately: taking the children to school and going on short family trips over rougher terrain. We also use it to transport 240kg tons of vegetable waste to feed our Bentheim pigs. Being able to rely on such a handy and manoeuvrable utility vehicle is great, especially as we carry out so many diverse operations.

Bernhard Zurhake, Zurhake Garten & Gestaltung, Visbek

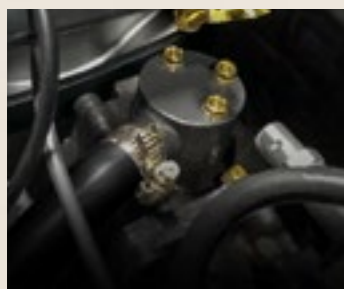

INTEGRATED HYDRAULICS

The K9 has an optional integrated hydraulic system for different attachments.



LARGE LOADING AREA & HIGH PAYLOAD

The large loading area - with a payload capacity of 500 kg - makes working with the K9 particularly easy. Hydraulic operation is available as an option.



HYDRAULIC DISC BRAKE

Durable, hydraulic disc brakes front and rear ensure excellent safety even when travelling at 40 or 50 km/h.



KIOTI DIESEL ENGINE

The 25 hp Stage V diesel engine runs smoothly and efficiently. On the K9 2400C, an engine brake acts via the CVT drive.



ADJUSTABLE STEERING WHEEL

The steering wheel is easy to adjust to suit individual drivers and the controls give the K9 an automotive feel.



DOORS AND CABIN

Available with ROPs frame and canopy, cabin with half doors or full cabin with optional heater. The K9 can meet individual requirements.



DASHBOARD

The elements of the digital Dashboard are ergonomically designed and easy to read at any time.



12V AND USB PORTS

Thanks to the 12V and USB ports, various devices can be conveniently charged while driving.



K9 Series



Model		K9 2400U-EU (red or green)	K9 2400C-EU (red or green)
Engine			
Type		Water-cooled three-cylinder 4-stroke diesel in-line engine	Water-cooled three-cylinder 4-stroke diesel in-line engine
Manufacturer		KIOTI	KIOTI
Emission tier		Stage 5 compliant	Stage 5 compliant
Maximum engine power	hp (kW)	24.3 (18)	24.8 (18,3)
No. of cylinders		3	3
Engine displacement	cc	1,007	1,007
Rated speed	rpm	3,000	3,200
Fuel tank capacity	l	37	37
Drive train			
Type		Drive belt, continuously variable (CVT)	Drive belt, continuously variable (CVT)
Gear ranges		L-H-N-R	L-H-N-R
Maximum speed (forward)	km/h	0 - 40	0 - 50
Brakes		Hydraulically disc brakes all round	Hydraulically disc brakes all round
Engine brake		-	Std.
Wheel suspension			
Front wheel suspension		Independent, double wishbone	Independent, double wishbone
Front suspension: total	mm	170	130
Front suspension: compression	mm	35	35
Front suspension: extension	mm	135	95
Rear wheel suspension		Independent, double wishbone	Independent, double wishbone
Rear suspension: total	mm	200	160
Rear suspension: compression	mm	110	70
Rear suspension: extension	mm	90	90
Steering			
		Hydrostatic power steering	Electric power steering (EPS)
Dimensions			
Overall length	mm	3,045	3,045
Overall width	mm	1,590	1,640
Overall height with sun canopy	mm	1,950	-
Overall height with full cabin	mm	2,050	1,990
Wheel base	mm	2,180	2,180
Min. ground clearance	mm	317	265
Unladen weight (basic equipment)	kg	930	1,050
Loading area payload	kg	500	500
Total payload	kg	770	650
Permissible total weight	kg	1,700	1,700
Tow-able load (unbraked)	kg	590	530
Turning radius	m	4.3 (2WD)	4.6 (2WD)
Loading area			
Length x width x height	mm	1,110 x 1,480x293	1,110 x 1,480x293
Single-hand tailgate op		Std.	Std.
Assisted bed tipping device		Hyd.	Elec.
Wheels & Tyres			
Wheel rims		Steel or alloy	Alloy
ATV off-road tyres		Front 25x10x12, rear 25x10x12	Front 25x10x12, rear 25x10x12
General purpose Worksite tyres		Front 25x10x12, rear 25x10x12	Front 25x10x12, rear 25x10x12
Grass tyres		Front 25x10x12, rear 25x10x12	Front 25x10x12, rear 25x10x12
Large ATV off-road tyres		Front 26x10x12, rear 26x10x12	-
Passenger cabin			
Number of seats		1 driver's seat, 2 passenger seats (bench)	1 driver's seat, 2 passenger seats (bench)
Roll bar		Std.	-
Full cabin (heater included)		Opt.	-
Full cabin (heater and air conditioner included)		-	Std.
Opening windscreen (safety glass with wiper)		Opt.	Std.
Doors (plastic, half-open)		Opt.	-
Doors (closed, with manual window opener)		-	Std.
Sun canopy (plastic)		Opt.	-
Floor mat (rubber)		Opt.	Std.
Headrests		Opt.	Std.
Speedometer		Std.	Std.
Radio		-	Opt.
Working lights (front)		Opt.	Opt.



STORAGE

Large and convenient storage areas built in to the dashboard for the secure storage of essential items



WINDSCREEN AND WINDSCREEN WIPERS

Available as an option for the K9, windscreen and windscreen wipers to protect the driver from wind and bad weather.



LIGHTING

The K9 is supplied with StVZO-compliant lighting as standard.



WORK LIGHTS

A work light kit is available as an option increasing visibility in low light. On the K9 2400C, this is already integrated into the roof as standard.



INDEPENDENT SUSPENSION

Both the front and rear wheels are suspended individually via robust double wishbones, ensuring a pleasant ride in any terrain.



TYRES

The heavy duty tyres are suitable for any application, while the coarse tread tyres are used where additional traction is required.



HITCH

The K9 comes with a clevis hitch at the front and a clevis draw bar at the rear complete with pins.



FRONT LINKAGE

Thanks to the optional hydraulic package, the K9 can be equipped with a front linkage (EcoTech) to use attachments such as a snow blade.



KIOTI Zero-turn Mower (ZTR) – Built for High Performance

ZX Series (24–25 hp)

- ZXR = Standard version.
- ZXC = Professional version.
- Excellent cutting quality.
- Extremely manoeuvrable zero-turn steering.
- Compact design for easy access.
- Simple and robust construction.
- Welded, indestructible mowing deck.
- Key-less start.
- Stable collision protection in the rear.
- Large fuel supply.
- Premium drives from Hydro-Gear ©.
- Convenient cutting height adjustment.
- Integrated LED headlights (Optional on ZXR).
- Easy maintenance.



COLLISION PROTECTION

Working in tight spaces at speed can lead to mis-hap. The rear impact protection helps protect the engine and drive from collisions.



KEYLESS START

All you need to do is enter a PIN code for ignition. Handing over keys when changing drivers is a problem of the past.



SIMPLE CUTTING HEIGHT ADJUSTMENT

The cutting height of the mower can be easily and finely adjusted from the seat via a rotary wheel.



POWERFUL MOWERS

The mowers produce an excellent finish. The drive is easily accessible for maintenance via a flap in the driver platform.

ZX Series

Model	ZXR48-EU	ZXC48SE-EU	ZXR54-EU	ZXC54SE-EU
Engine				
Field of application	Private use	Commercial use	Private use	Commercial use
Manufacturer / Type	Briggs & Stratton Professional Series™	Briggs & Stratton Commercial Series™	Briggs & Stratton Professional Series™	Briggs & Stratton Commercial Series™
Maximum engine power hp (kW)	24 (17.89)	25 (18.64)	24 (17.89)	25 (18.64)
Engine capacity cc	724	724	724	724
Choke	Automatic	Manual	Automatic	Manual
Type of fuel	Petrol	Petrol	Petrol	Petrol
Fuel tank capacity l	28.4 (1 tank, left-hand side)	47.3 (2 tanks, left & right)	28.4 (1 tank, left-hand side)	47.3 (2 tanks, left & right)
Mower deck				
Cutting width cm	122	122	137	137
Cutting height mm	38 - 127	38 - 127	38 - 127	38 - 127
Type	Welded	Welded	Welded	Welded
Discharge	Lateral (discharge channel from moulded rubber)	Lateral (discharge channel from moulded rubber)	Lateral (discharge channel from moulded rubber)	Lateral (discharge channel from moulded rubber)
Mower deck lift / lower	Mechanical via ergonomic foot pedal	Mechanical via ergonomic foot pedal	Mechanical via ergonomic foot pedal	Mechanical via ergonomic foot pedal
Number of guide wheels (F/R)	6 (4/2)	6 (4/2)	6 (4/2)	6 (4/2)
Mulch kit	Optional	Optional	Optional	Optional
Drive train				
Manufacturer / Type	Hydrogear ZT2800	Hydrogear ZT3400	Hydrogear ZT2800	Hydrogear ZT3400
Drive shaft (diameter) mm	25.4	28.6	25.4	28.6
Torque Nm	406	677	406	677
Maximum speed (forward) km/h	12.9	16.1	12.9	16.1
Hand brake	Integrated in axle	Integrated in axle	Integrated in axle	Integrated in axle
PTO				
Switch	Electronic	Electronic	Electronic	Electronic
Coupling	Standard	Heavy Duty	Standard	Heavy Duty
Electrics				
Voltage Volt	12	12	12	12
Dimensions				
Length mm	2,050	2,050	2,050	2,050
Width (tyre to tyre) mm	1,278	1,303	1,278	1,303
Width (Inc. discharge channel) mm	1,711	1,711	1,711	1,711
Height (inc. folding bracket) mm	1,791	1,816	1,791	1,816
Wheelbase mm	1,232	1,232	1,232	1,232
Curb weight kg	413	434	413	434
Tyres				
Front	13x5-6	13x6.5-6	13x5-6	13x6.5-6
Rear	22x9.5-10	23x10.5-12	22x9.5-10	23x10.5-12
Seat				
Suspension	-	Premium suspension with a high backrest	-	Premium suspension with a high backrest
Horizontal adjustment	Std.	Std.	Std.	Std.
Backrest	Normal	Extra high	Normal	Extra high
Armrest	Std.	Std.	Std.	Std.
Security				
Folding bracket	Std.	Std.	Std.	Std.
Contact seat switch	Std.	Std.	Std.	Std.
Coded ignition	Std.	Std.	Std.	Std.
Extras				
LED work lights	Opt.	Std.	Opt.	Std.
Additional work spotlight	Opt.	Opt.	Opt.	Opt.
Additional mower guide wheels	Opt.	Opt.	Opt.	Opt.
Rear towing eye	Opt.	Std.	Opt.	Std.
Area performance				
80% productivity ha/h (ca.)	1.41	1.76	1.41	1.76



Front Loader

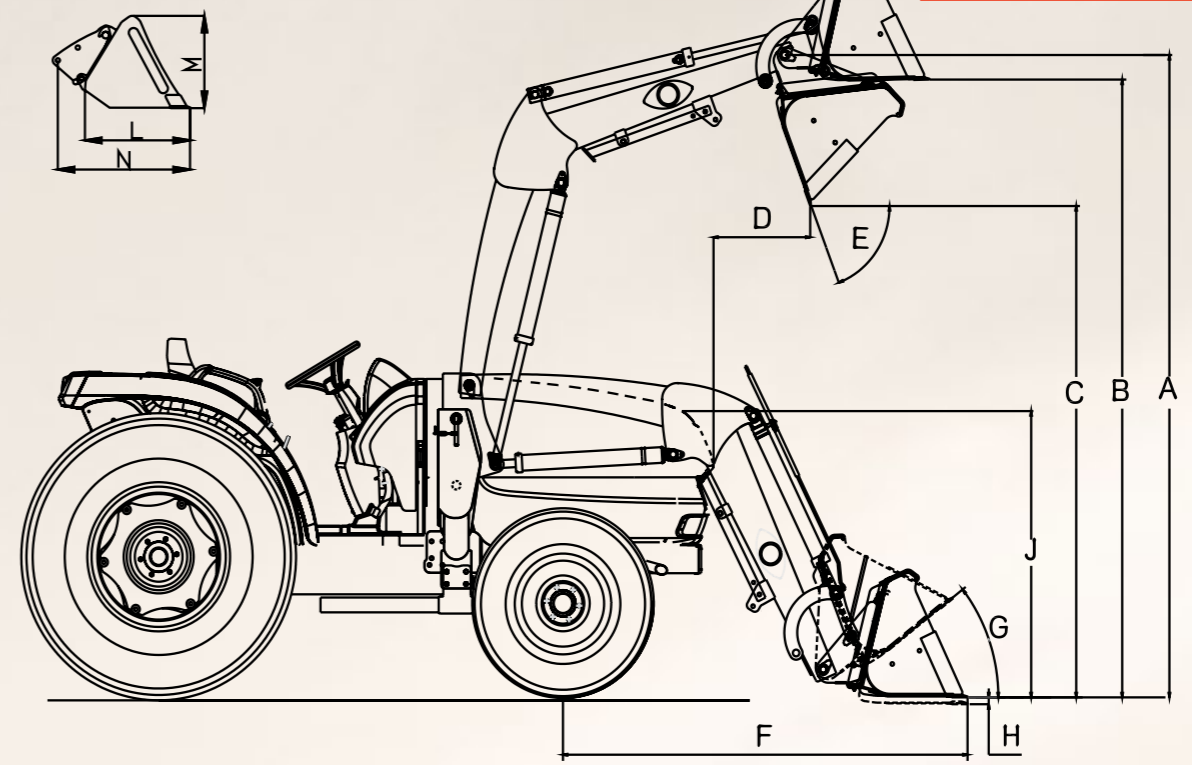

Compact Front Loader for Large Tasks

KL Series

- Robust construction.
- Optimal design for an outstanding lift.
- Low front axle load mounting.
- Precise mechanical parallel guidance.
- Perfect for KIOTI tractors.
- Standardised hitch for fast attachment changeover.
- Easy attachment and removal from the tractor.
- Operation via four-way lever.
- Changeover valves for hyd device operation (Optional).

Model		KL115A	KL115	KL115C	KL2510	KL4010	KL5510	KL7320	KL1103
Suitable for		CS2220U	CS2510H	CS2520H	CX-Series	CX-Series	DK-Series	RX-Series	PX-Series
Lifting force at tool pivot point (@ max. lifting height)	kg	527	527	527	495	766	1,207	1,535	1,941
Breakout force at tool pivot point	kg	875	875	875	835	1,162	1,769	2,431	2,775
Bucket breakout force (when tilting)	kg	288	288	288	863	1,363	2,227	2,155	3,432
Maximum lifting height at tool pivot point (A)	A mm	1,842	1,793	1,788	2,230	2,500	2,768	3,400	3,670
Loading height	B mm	1,682	1,632	1,628	2,141	2,234	2,449	3,123	3,307
Dump height	C mm	1,386	1,336	1,332	1,706	1,839	2,075	2,599	2,703
Dumping width	D mm	572	572	538	800	321	460	519	522
Tipping angle - upwards	E deg	73.8	73.8	74	53	55.5	58	47	60.3
Shovel Edge Reach (Bottom)	F mm	1,331	1,369	1,371	1,520	1,660	1,800	2,043	2,413
Tilt angle (down)	G deg	35	35	35	35	41.5	38.9	54	49.5
Digging depth	H mm	64	114	117	99	124	231	166	271
Overall height in transport position	J mm	1,157	1,065	1,104	1,016	1,345	1,465	1,760	2,048
Depth of bucket (inside)	L mm	374	374	374	505	485	470	592	720
Shovel Height (Vertical)	M mm	452	452	452	526	501	560	581	641
Depth of bucket (external)	N mm	485	485	485	682	665	660	838	907
Blade width	mm	1,220	1,220	1,220	1,270	1,524	1,676 / 1,830	2,083	2,210
Shovel capacity	m ³	0.17	0.17	0.17	0.19	0.19	0.41 or 0.45	0.60	0.78
Total weight with shovel	kg	209	210	209	274	412	651	860	1,020
Mechanical parallel guidance		Std.	Std.	Std.	-	Std.	Std.	Std.	Std.
Attachment plate		KIOTI (Opt.)	KIOTI (Opt.)	KIOTI (Opt.)	SKID (Std.)	EURO (Std.)	EURO (Std.)	EURO (Std.)	EURO (Std.)
Switching valve for hyd. attachments		Opt.	Opt.	Opt.	Opt.	Opt.	Opt.	Opt.	Opt.



COLLISION PROTECTION

Each KIOTI front loader features a partly foldable collision protection guard, protecting the tractor's front end.



POSITION

The position of the attachment can be checked at any time via the mechanical display.



FOUR-WAY CONTROL LEVER

All KIOTI front loaders are operated using a four-way control lever.



INTEGRATION

KL front are designed fit to KIOTI tractors, proving great all-round visibility.



QUICK CHANGE

For a quick change of attachments, the KL loaders have incorporate a quick-change locking mechanism.



FRONT BUCKET

The KIOTI attachments are built for tough use, providing reliable support every day.



ATTACHMENTS

A variety of high-quality attachments are available on request.



SM SERIES (137-152 CM)

The KIOTI-SM mid-deck mowers are designed for use with the CS range of tractors:

- Mulch insert, side ejection optionally with classic side suction
- Cutting height adjustment from the driver's seat.
- Robust construction with reliable drive.
- Attachment by driving over the mower (SM2420-54), or inserted sideways.



MOW-MM 152 (Matev)

The Matev MOW-MM 152 mid-deck mower is designed for use with the CX 2510 tractor:

- 152cm / 60" cutting width
- Mulch insert, rear or side ejection, optionally with classic side extraction.
- Suction integrated into the mower, for almost border-less mowing on both sides.
- Four caster sprung guide wheels.
- Attachment by driving over the mower, or inserted sideways using the new Matev quick-change system.

Manufacturer	KIOTI		Matev
Model	SM2420-54	SM2410	MOW-MM 152
Suitable for	CS Series		CX Series
Discharge (direction of travel)	Right	Right	Right or rear
Mulch kit	-	Opt.	Opt.
Cutting width	Inch (cm)	54" (137)	60" (152)
Total width (incl. chute)	cm	176	183
Transport width	cm	144	158
Cutting height	cm	2.3-9.6	3.0-11.0
Ground clearance in transport position (turf tyres)	cm	15.2	11.0
Blades - quantity		3	3
Lift with three-point linkage		Std.	-
Hydraulic lift		Opt. (only CS2520H)	Std.
Can be combined with KIOTI front loader		Yes	Yes
Can be combined with front linkage		Yes	Yes
Weight - base machine	kg (ca.)	113	150



Type	Agricultural narrow	Agricultural wide	Industrial	General purpose	Turf
	Diagonal	Radial	Diagonal	Radial	Diagonal
Characteristics*	Robustness	Very high	High	Very high	Average
	Traction	Very high	Very high	Average	High
	Driver Comfort	Average	High		Very high
	Self Cleaning	Very high	Very high	Average	High
Key Points*	Road Travel	+	++	++	+++
	Concrete/pavement	++	++	+++	+++
	Field	+++	+++	+	++
	Grassland	+	++	++	+++
	Forest	+++	+++	+	+
	Horse Arena	-	+	+++	+++
	Car Park	-	-	+	++
Comments		Narrow cleated ag tyre. Well suited in fields and forests, especially when operating in confined spaces.	Cleated radial ag tyre. Great traction and lower ground pressure in the field. Better driving comfort.	Flat profile industrial tyre. Well suited for concrete floors, horse arenas and general yard work.	All round tyre well suited for a wide range of applications, including grassland, yard work and road transport.
					Professional turf tyre for sensitive green spaces. Also performs well in winter and on the road. Can be driven with very low tyre pressure.

* The data contained within this table is for reference only, intended to give indication about the suitability of the different tyre choices in varying conditions.

	Model	Dimensions**				
		Agricultural narrow Diagonal	Agricultural wide Radial	Industrial Diagonal	General purpose Radial	Turf Diagonal
Sub Compact	CS2220	Front 5-12 6PR Rear 8-16 6PR	Front 23x8.5-12 Rear 260/70R16	Front 18x8.5-10 Rear 26x12.00-12	-	Front 18x8.5-10 Rear 26x12.00-12
	Overall width (mm)	1.070	1.187	1.169	-	1.185
	Height with cabin (mm)	-	-	-	-	-
	CS2510 & CS2520	-	-	Front 18x8.5-10 Rear 26x12.00-12	-	Front 18x8.5-10 Rear 26x12.00-12
	Overall width (mm)	-	-	1.169	-	1.185
Small Chassis	CX2510	Front 6-12/4 Rear 9.5-18/8	-	Front 23x8.5-12 Rear 12-16.5	Front 220/55R12 Rear 280/70R16	Front 23x8.5-12 Rear 33x12.5-16.5
	Overall width (mm)	1.169	-	1.290	1.247	1.300
	Height with cabin (mm)	2.200	-	2.168	2.153	2.170
	CK2630-CK5030	Front 7-16 Rear 11.2-24	Front 240/70R16 Rear 360/70R24	Front 25x8.5-14 Rear 15-19.5	Front 240/70R16 Rear 360/70R24	Front 27x8.5-15 Rear 41x14-20
	Overall width (mm)	1.385	1.497	1.595	1.510	1.543
Large Chassis	DK4520-DK6020	Front 8-16 Rear 12.4-24	Front 280/70R16 Rear 360/70R24	-	Front 280/70R16 Rear 380/70R24	Front 29x12-15 Rear 475/65D20
	Overall width (mm)	1.503	1.608	-	1.656	1.814
	Height with cabin (mm)	2.363	2.364	-	2.380	2.348
	DK4520-DK6020	-	Front 280/70R16 Rear 380/70R24	-	Front 280/70R16 Rear 420/70R24	-
	Overall width (mm)	-	1.631	-	1.735	-
Utility	RX7330	Front 11.2-24 Rear 16.9-30	Front 280/85R20 Rear 380/85R30	-	-	-
	Overall width (mm)	1.960	1.835	-	-	-
	Height with cabin (mm)	2.686	2.643	-	-	-
Small Ag	HX-Series	-	Front 380/70R24 Rear 480/70R34	-	-	-
	Overall width (mm)	-	2.145	-	-	-
	Height with cabin (mm)	-	2.801	-	-	-

** This overview includes the most common tires. Please contact your KIOTI sales partner for further tire options or individual special requests. It may be that not all tires are available for all models in a series. Some tires require individual acceptance or entry in the vehicle documents. All statements without guarantee.



Your local KIOTI dealer: