

# CLIPEX<sup>®</sup>

## ANIMAL HANDLING PRODUCT RANGE



STOCKED BY  
**THORBURN**  
GROUP



# ABOUT US

Clipex Fencing and Animal Handling products have been at the heart of innovation in the agricultural industry since 2007 when the company's founder, Ashley Olsson, made the decision to create a company capable of providing affordable engineered solutions for rural families. Since then, Clipex has revolutionised fencing and animal handling products.

Each product has been developed with a focus on safe handling, efficient farming practises and affordability. All our products from design concept to farm yards are created with the end user in mind.

Thorburn Group, based in Duns in the Scottish Borders, are one of the main Clipex Dealers in the United Kingdom, having specialised in Livestock Handling Solutions for over 20 years, they are well experienced and know exactly what equipment will work well for your farm. Thorburns create bespoke handling systems which can be designed around a specific Clipex Handling Solution.

To discuss individual enquiries, please contact our sales team and find out how Thorburn Group and Clipex can make your farm safer.



**PERSONALISED SOLUTIONS BUILT & COMPLETED  
BY OUR VERY OWN CLIPEX TEAM**

**GET A QUOTE**

**CALL**

01361 883245

**EMAIL**

[enquiries@thorburngroup.co.uk](mailto:enquiries@thorburngroup.co.uk)

**ONLINE**

[www.thorburngroup.co.uk](http://www.thorburngroup.co.uk)

**VISIT**

Thorburn Group, Unit 1,

Duns Industrial Estate, Station Road,

Duns, Berwickshire, TD11 3HS

# CONTENTS

## CATTLE

- HDX 900 Series Cattle Crush
- HDX 1100 Series Cattle Crush
- HD 1500 Cattle Crush
- HD 2000 Cattle Crush
- Cattle Accessories
  - Head Bail
  - Head Scoop
  - Gates
  - Cattle Crush Components
- Forcing Tub
  - Manual & Pneumatic
- Permanent Cattle Yards

04

## SHEEP

- Automatic Sheep Handler
- Auto Sheep Drafter
- Sheep Yards
  - Permanent & Semi-Permanent
- Sheep Components

18

## EQUINE

- Equine Range

26

# HDX 900 SERIES

## Manual Crush



### SINGLE SQUEEZE

- Chin Bar included.
- Heavy duty 100x series head bail.
- Fool proof operation with nylon brushes for silent and maintenance free operation.
- Single parallel squeeze.
- Infinite, silent lock on head bail & squeeze.
- Slam catches on all swinging doors.
- Head bail handle at front and rear.
- Galvanised heavy duty construction.
- Full vet section.
- 120mm anti-bruise rail.
- Split gates both sides.
- Sheeted slide gate and bottom doors.
- Load Bar mounts on feet.
- In-built floor section.
- 12 month warranty.

**The *HDX 900 SERIES CATTLE CRUSH* is a single squeeze, and our most affordable Clipex Crush. Featuring silent operation, ideal for keeping cattle at ease. Nylon brushes are used to create a maintenance free process and it even includes the heavy duty 100x series Head Bail.**





## FEATURES & SPECIFICATIONS

Product Code	CH-HDX900VC
VET Section	YES
Internal Lenth	2980MM
Internal Width	770MM
Minimum Squeeze Width	500MM
Manual Operation	YES
Pneumatic Operation	NO
Squeeze	SINGLE SIDE PARALLEL
Headbail Lock	ULTRA LOCK HYDRAULIC CELL
Headbail	MANUAL
Total Height	2250MM
Weight	840KG
Corrosion Protection	HOT DIPPED
Steel Corner Castings	NO
Entry Gate	MANUAL SINGLE SLIDE
Slam Catches	SLAM CATCHES
Rump Bar	YES
Side Access Doors	7
Head Holder	INCLUDED
Floor	WELDED FLOOR INCLUDED
Access Door Options	NO
Offside Option	YES
Automation Options	N/A
Front Adapter Posts	OPTIONAL
Warranty	12 MONTHS

# HDX 1100 SERIES

## Manual Crush



### DOUBLE SQUEEZE

- Head Scoop Included.
- Double Parallel Squeeze.
- Infinite, silent lock on head bail & squeeze.
- Anti-rattle catches on all swinging doors.
- Front & Rear head bail handle.
- Hot dip galvanised.
- Full Vet Section.
- 120mm anti-bruise rail.
- Split gates both sides.
- Sheeted slide gate and bottom doors.
- Load bar mounts on feet.
- In-built floor section.
- Rubber flooring over sheet metal.
- Lifting eyes on top of crush for easy transportation.
- Weighing options.
- Available in both left and right hand access.

The **HDX 1100 SERIES CATTLE CRUSH** is a double squeeze, and the best Cattle Crush in the PGX Series. This durable design allows you to squeeze the animal in the middle, to ensure safer and easier operations. The squeeze can also be used to slow down cattle to enable an easier catch.



## FEATURES & SPECIFICATIONS

Product Code	CH-HDX1100VC
VET Section	YES
Internal Lenth	2980MM
Internal Width	770MM
Minimum Squeeze Width	320MM
Manual Operation	YES
Pneumatic Operation	NO
Squeeze	DOUBLE SIDE PARALLEL
Headbail Lock	ULTRA LOCK HYDRAULIC CELL
Headbail	MANUAL
Total Height	2250MM
Weight	950KG
Corrosion Protection	HOT DIPPED
Steel Corner Castings	NO
Entry Gate	MANUAL SINGLE SLIDE
Slam Catches	SLAM CATCHES
Rump Bar	YES
Side Access Doors	7
Head Holder	INCLUDED
Floor	WELDED FLOOR INCLUDED
Access Door Options	NO
Offside Option	YES
Automation Options	N/A
Front Adapter Posts	OPTIONAL
Warranty	12 MONTHS



# HD 1500 SERIES

## *Pneumatic Crush*

### PARALLEL SQUEEZE

- Pneumatic Operation.
- 450 grade steel.
- Double Parallel Squeeze.
- Hot dip galvanised.
- Anti-rattle catches on all swinging doors.
- Super duty head scoop.
- Animal inspecting doors.
- Nylon brushes in all hinges.
- Three unique side doors for easy animal access.
- Infinite, silent lock on head scoop.
- Slam catches on all swinging doors.
- Clipex castings on steel corners.
- Full Vet section.
- Anti-bruise rail.
- Sheeted slide gate and bottom doors.
- Weigh bar mounting points.
- Excellent for calf access.
- Floor – HD Expanded mesh with polyurethane.
- Customisable door configurations.
- 1500kg construction.
- Lifting eyes on top of crush for easy transportation.
- Available in both left and right hand access.

**The *HD1500 SERIES CATTLE CRUSH* is a double parallel squeeze, Pneumatic model built to last and engineered to perform. Manufactured using 120x40 hot dip galvanised HD rail type, to create an extremely strong and durable crush, while reducing bruising and animal stress.**



## FEATURES & SPECIFICATIONS

Product Code	CH-HD1500VC
VET Section	YES
Internal Length	3150MM
Internal Width	750MM
Minimum Squeeze Width	350MM
Manual Operation	NO
Pneumatic Operation	YES
Squeeze	PARALLEL SQUEEZE
Headbail Lock	DOUBLE INFINITE LOCKING BAR
Headbail	HYBRID LOW AIR PRESSURE WITH MECHANICAL LOCK
Total Height	2290MM
Weight	1480KG
Corrosion Protection	HOT-GAL
Steel Corner Castings	YES
Entry Gate	PNEUMATIC SINGLE SIDE
Slam Catches	CLIPX RATTLE FREE SLAM CATCHES
Rump Bar	INDEPENDENT RUMP BAR DOOR
Side Access Doors	10 SERVICEABLE DOORS
Head Holder	INCLUDED
Floor	INCLUDED RUBBER FLOOR
Access Door Options	YES
Offside Option	YES
Automation Options	N/A
Front Adapter Posts	OPTIONAL
Warranty	5 YEARS

## 1500 Series

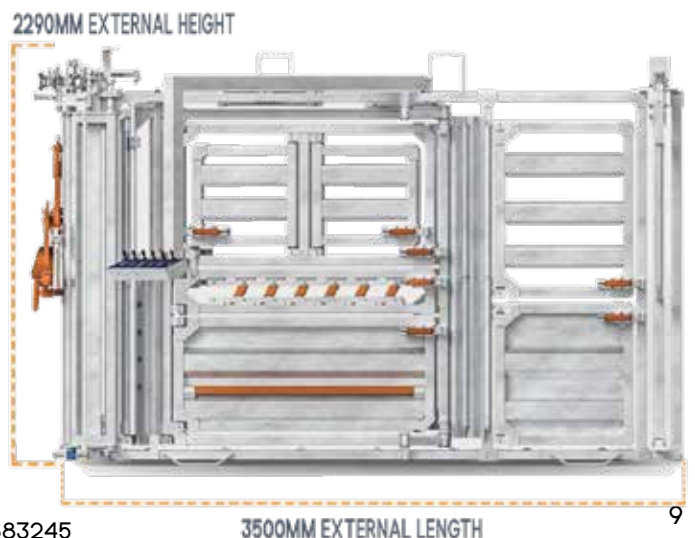
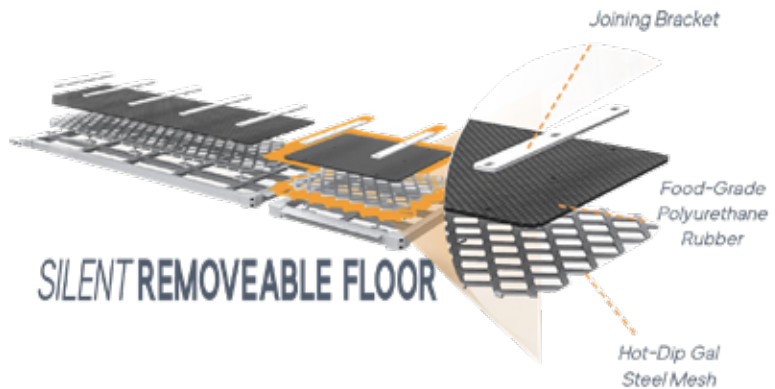
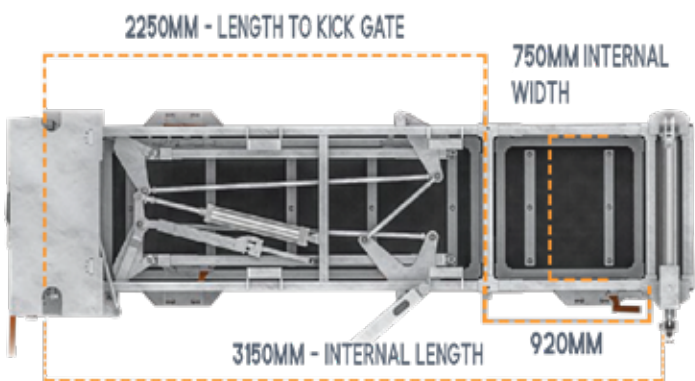

CALL US 01361 883245

# HD 2000 SERIES

## Pneumatic Crush

### PARALLEL SQUEEZE

- 450 grade steel.
- Hot dip galvanised.
- Anti-rattle catches on all swinging doors.
- Super duty head scoop.
- Animal inspecting doors.
- Nylon brushes in all hinges.
- 3 unique side doors for easy access.
- Infinite, silent lock on head scoop.
- Slam catches on all swinging doors.
- Manual override option.
- Clipex castings on steel corners.
- Auto lock rear sliding gate.
- Removable floor standard.
- Full Vet section.
- Anti-bruise rail.
- Weigh scale mounting points.
- Excellent for calf access.
- Floor – HD Expanded mesh with polyurethane.
- Customisable access door configurations.
- Weighing options.
- 2000kg construction.
- Lifting eyes on top of crush for easy transportation.
- Available in both left and right hand access.
- Heavy duty "split" entry gate.
- Auto locking rear sliding gate.
- Large control panel available on AUTO model.
- Automated weighing with auto drafting capabilities.
- Side draft capability.
- 4-6 way draft capable.
- Reduce labour costs.

The **HD2000 SERIES CATTLE CRUSH** is a double parallel squeeze, Pneumatic model built to last and engineered to perform. Manufactured using 120x40 hot dip galvanised HD rail type, to create an extremely strong and durable crush, while reducing bruising and animal stress.

## FEATURES & SPECIFICATIONS

Product Code	CH-HD200VC
VET Section	YES
Internal Length	3450MM
Internal Width	750MM
Minimum Squeeze Width	350MM
Manual Operation	NO
Pneumatic Operation	YES
Squeeze	PARALLEL SQUEEZE
Headbail Lock	DOUBLE INFINITE LOCKING BAR
Headbail	HYBRID LOW AIR PRESSURE WITH MECHANICAL LOCK
Total Height	2290MM
Weight	1860KG
Corrosion Protection	HOT-GAL
Steel Corner Castings	YES
Entry Gate	PNEUMATIC SPLIT DOORS
Slam Catches	CLIPX RATTLE FREE SLAM CATCHES
Rump Bar	INDEPENDENT RUMP BAR DOOR
Side Access Doors	10 SERVICEABLE DOORS
Head Holder	INCLUDED
Floor	INCLUDED RUBBER FLOOR
Access Door Options	YES
Offside Option	YES
Automation Options	OPTIONAL
Front Adapter Posts	OPTIONAL
Warranty	5 YEARS

2290MM EXTERNAL HEIGHT

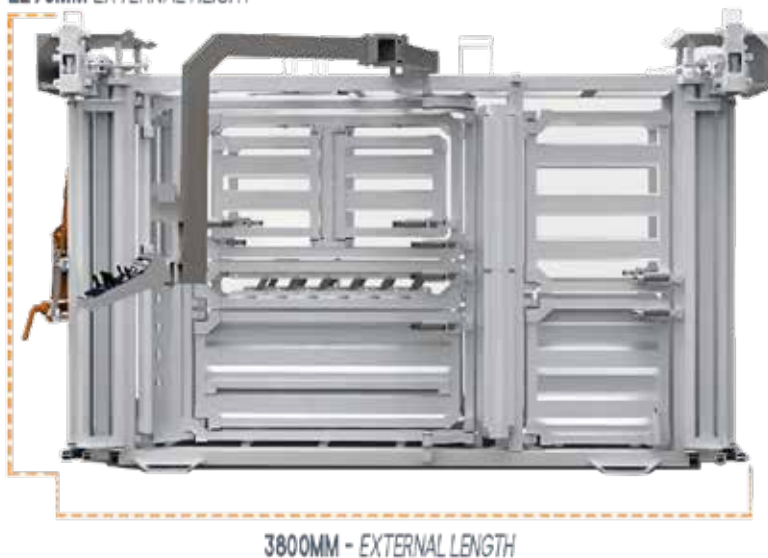

# 2000 Series

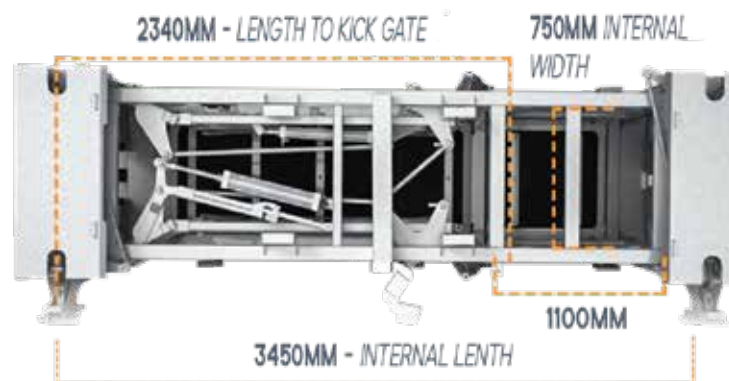

## AUTOMATIC DRAFTING OPTION



- The HD 2000 series crush comes with an automatic option that enables auto drafting on weight or EID, either through the side draft, or through our 5 way drafter module. The auto upgrade also includes remote control ability, to control the crush.
- Fully pneumatic with autonomous control.
- Comes complete with heavy duty floor & chin bar.
- Included load bar mount points for recommended 4500kg load bars.



# CATTLE ACCESSORIES

*Head Bail, Head Scoop, Gates, Components*



## HDX HEAD BAIL

If you only require the Head Bail, you can purchase our highly rated HDX Series Head Bail on it's own, we can even fit it into your cattle yard, if that is something you require. Not only is the Head Bail more responsive, the sound is kept to an absolute minimum.

### FEATURES:

- Infinite locking system.
- Rubber Design.
- Minimal gaps.
- Nylon brushes.
- Noise dampening panelling.
- Silent operations.
- HD galvanised construction.
- Heavy duty construction.
- Drop-down safety handle.
- Included with: HDX900 & HDX1100.

## GATES

The Clipex Studman Gates and Panels are Hot Dip Galvanised to improve strength and durability, complete with anti-bruising for animal and handler. To find out the size options available, get in touch on 01361 883245.





## HEAD SCOOP

The Clipex Head Scoop can be bought separately, or with one of the Crushes, featuring a lock release and extendable handle.

### FEATURES:

- Head brace.
- Lock release.
- Infinite locking mechanism.
- Extendable handle.
- Adjustable width.
- Nylon brushes in chin bar.

## CATTLE CRUSH COMPONENTS

Each of the different crush components are hot dip galvanised to improve strength and longevity, ensuring your cattle systems will last for years to come. Hot Dip Galvanising has approximately 600% more bonding strength than zinc rich paint, preventing the steel from rusting quickly. We have a range components to suit your individual system, get in touch for more details.

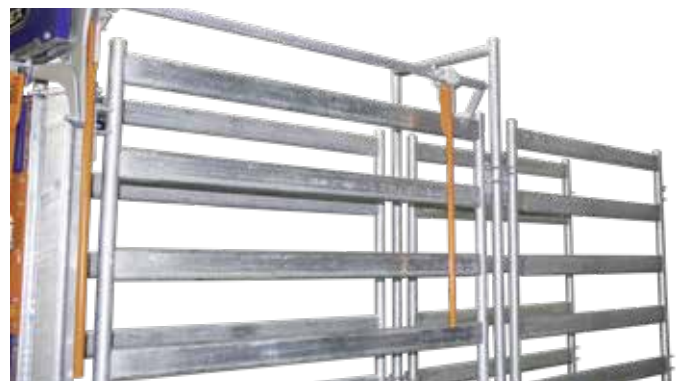

# FORCING TUB

*Pneumatic & Manual*



**Our patent featuring Forcing Tub – available in Pneumatic or Manual, was developed from the ground up to be the most efficient in its class featuring automatic processing. Both models are made from a hot dipped construction to improve strength and longevity. Suitable for 150–200 cattle, the tub automatically guides the cattle to the next section, streamlining the handling process.**

## **FEATURES:**

- HD Rotary Crowd Tub.
- Hot dip galvanised construction for longevity.
- Curved panels improves flow and reduces bruising.
- Walkway and platform.
- Adjustable with curved race.
- Adjustable v-straight race before crush improves flow.
- Designed to work with our HD2000 series auto crush for autonomous weighing and drafting. With compatible indicator, includes remote for head bail and draft (crush sold separately).
- Sheeted curved race.
- HD Sliding gates.
- 3-Way air draft module with access gates. Optional 5 way draft available.



## AUTOMATIC TUB

- Air operated via remote or control panel.
- Doors will automatically engage and disengage seamlessly to maximise flow.
- 360° rotation on doors, without need to return.
- Full walkway with multiple on and off areas
- Standard or wet-dry options available for internal race.
- Industrial rubber bumpers on doors for animal safety and reduced bruising.

## MANUAL TUB

- Ratchet operated.
- Doors automatically engage and disengage seamlessly to maximise flow.
- 360° rotation on doors, without need to return.
- Full walkway with multiple on and off areas.

SCAN THE QR CODE TO  
WATCH US BUILD THE  
SYSTEM ON YOUTUBE.



# CATTLE YARDS

## Permanent Solutions

We are driven by our on-going commitment to produce innovative farming solutions that make farming life easier, safer and are built to last. The dedicated team of Solutions Specialists, Engineering and Installations experts at Clipex work hand-in-hand with our clients to ensure that our purpose-built turnkey solutions are tailored to meet their individual needs.

The Clipex patented permanent yards were created from the ground up in consultation with farmers to become the most efficient in its class. Featuring a choice of pneumatic or manual operations and automatic processes, this range of premium quality solutions has been developed to be one of the safest, easiest and longest-lasting systems available.

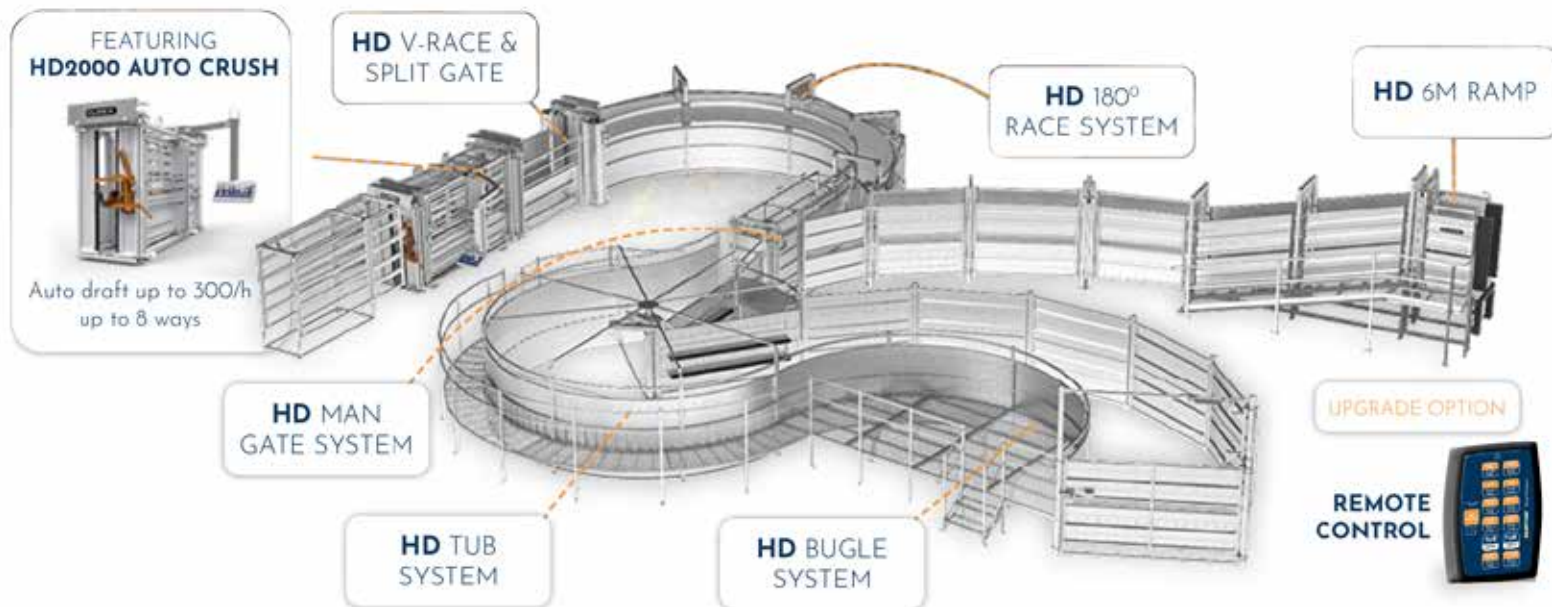

### HOT DIP GALVANISED

Galvanised materials to 600g/m<sup>2</sup>

### HEAVY DUTY CONSTRUCTION

Utilising premium 450 grade steel

### PATENTED TUB SYSTEM

Pneumatic operated with auto engaging doors

### CONCRETED POSTS

Rock solid heavy duty end posts

### BOLT & CLAMP SYSTEM

Panels bolted one side & clamped on other

### PREMIUM MANUFACTURING

All welds are welded in a horizontal position

### FLOATING RAIL 180 RACE

Made from super heavy duty 80mm tube and steel castings.

### HD WORK AREA SYSTEM

Lighter & cost effective alternative





### V-RACE & SPLIT GATE

- V-Race with width adjust on both sides.
- Pneumatic split slide gate.
- Ensuring single animal feed into cattle crush.



### 180° RACE SYSTEM

- Super heavy duty design
- 180° race & V-Race
- 2 air adjustable operating widths
- Floating rail system enables access to the animal while in the race.
- Made from super heavy duty 80mm tube and steel castings.
- Standard or wet-dry options available for internal race.



### MAN GATE SYSTEM

- Enables fast access to the either side of race.
- Includes safety pin locks on man gates
- Creates ability to lock off access to race.
- Draft for race or ramp direction.
- Ensuring operator safety.



### 3M TUB SYSTEM

- Air operated via remote or control panel.
- Doors will automatically engage and disengaged seamlessly to maximise flow.
- 360° rotation on doors, without need to return.
- Full walkway with multiple on and off areas
- Standard or wet-dry option available for race.
- Industrial rubber bumpers on doors for animal safety and reduced bruising.



### BUGLE SYSTEM

- Near 180° bugle
- Fully sheeted on both sides
- Walkway coverage of entire bugle area
- Allows space to effectively control animal stress & control stock movement.
- Rear full width entry gate with pneumatic options.



# AUTOMATIC SHEEP HANDLER

*Contractor or Fixed Models*

## FEATURES:

- Automatic drafting.
- Tilt table.
- Head access.
- Auto catching.
- Patented & auto pre-catch.
- Tail access.
- Tow hitch.
- Unique folding design.
- Weigh scale attachment.
- Electric jacks.
- Optional wireless foot pedal.
- Built to travel & increase productivity.
- Automated data collection.
- Included 3 way draft.
- Add a wireless foot pedal for full control.



The Clipex Sheep Handler is one of the best on the market, weigh and drafting up to 800 sheep an hour, handling up to 400 sheep an hour and crutching up to 120 sheep an hour. It includes a full tilt function which gives you access to the whole animal at a standing height and the patented pre-catch section revolutionises sheep handling.

The handler can easily be adjusted for different sized sheep and has automatic weighing for up to five way drafting. There are nylon brushes on all moving parts creating a truly silent operation to help sheep move through stress free.



**INCLUDED 3 WAY DRAFT**



**CATCH & TILT**



**PATENTED PRE-CATCH**

## MACHINE CONTROL



- CATCH
- RELEASE
- DRAFT
- SHEEP & GOAT HANDLER PRO & SHEEP & GOAT HANDLER PLUS



- CATCH & RELEASE
- TILT
- TILT RETURN\*
- SHEEP & GOAT HANDLER & SHEEP & GOAT DRAFTER

**DRAFT 800  
SHEEP  
PER HOUR**

**HANDLE  
UP TO  
400 SHEEP  
PER HOUR**

**CRUTCH  
UP TO 120  
SHEEP  
PER HOUR**

## CONTRACTOR OR FIXED MODEL?

If you opt for the Contractor Model, your Sheep Handler comes with features not included in the Fixed Model. A fully portable and mobile trailer, with off road axles and tow-bar, attaching to your vehicle for portable flexibility. This model comes with three electric jacks, which are height adjustable allowing you to lower the trailer to a more comfortable height for the operator and the wheels remove easily out of the way.

	Contractor Model	Fixed Model
Weight	800KG	700KG
Auto Catch	YES	YES
Tilt	YES	YES
Anti-Backing Flap	YES	YES
Head Flap Access	YES - FULLY TILTED	YES
Tail Flap Access	YES - FULLY TILTED	YES
Auto Pre-Catch Area	YES	YES
Electric Jacks	YES	NO - UPGRADE TO CONTRACTOR MODEL
Load Bars	YES	OPTIONAL UPGRADE
Hungry Board	OPTIONAL UPGRADE	OPTIONAL UPGRADE
Remote Foot Pedal	OPTIONAL UPGRADE	OPTIONAL UPGRADE
3 Way Auto Draft	YES	YES
Rubber Matting	YES	YES
Can be towed	YES	NO (UPGRADE TO CONTRACTOR)
Wireless Remote	YES	OPTIONAL UPGRADE
5 Way Draft	OPTIONAL UPGRADE	OPTIONAL UPGRADE



# AUTO SHEEP DRAFTER

*6 in 1 Auto Drafter*

The ClipeX 6 in 1 Auto Sheep Drafter is not only an incredibly fast auto drafter, but also to perform most critical tasks with ease. The Handler enables weighing, drafting, drenching, needling, mouthing & dagging in a compact design that can fit into most sheep yards.



## FEATURES:

- Affordable workhorse.
- Improve your flock data.
- Easy accurate weight gain mapping.
- Save your back & body.
- Included 3 way draft.
- Stationary catch platform.
- Straight lead up race.
- Rear access standing up.
- Front access standing up.
- Includes anti-backing hock bar.
- Catch and hold ensuring accurate weights.
- Auto Draft up to 800 sheep an hour.
- Drench up to 400 sheep per hour.
- Fully restrained, easy access needling.
- Open front access for easy mouthing.
- Stand up dagging with rear ccess.



**INCLUDED 3 WAY DRAFT**

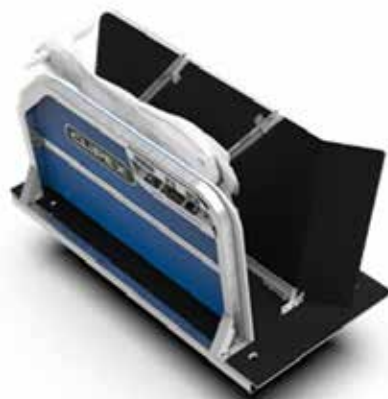

**STATIONARY CATCH PLATFORM**



**STRAIGHT LEAD UP RACE**



### FITS MOST YARDS

The Clipex Drafter suits most yard designs, simply put the drafter in place, and start drafting!



### AUTO CATCHING

Automatically catches and clamps the sheep quickly for weighing accuracy. The catch position is also fully adjustable.



### AUTO DRAFTING

Using a weigh indicator, the handler can draft up to 5 ways with a supported weigh scale indicator. The handler comes standard with 3 way drafting.



### MAXIMUM FLOW

Using our Backing Flap and Entry Gate system, sheep flow through effortlessly without weight errors or double catches.

## WHAT IS THE DIFFERENCE BETWEEN THE SHEEP HANDLER & AUTO DRAFTER?

### 6 in 1 Auto Sheep Drafter



#### NO TILT FUNCTION

- Rear access standing up
- Front access standing up

#### STRAIGHT RACE

- Short race lead up area to extend existing race. Includes anti-backing hock bar.

### All in One Sheep Handler



#### FULL TILT ACCESS

- Full Tilt
- Better Rear Access
- Better Front Access

#### PRE-CATCH AREA

- Auto catch and preload sheep.
- Ability to easily drench in area.



# SHEEP YARDS

*Permanent & Semi-Permanent*



## PERMANENT YARD FEATURES:

### **HOT DIP GALVANISED**

Galvanised materials to 600g/m<sup>2</sup>

### **HEAVY DUTY CONSTRUCTION**

Utilising premium 450 grade steel.

### **PREMIUM MANUFACTURING**

All welds are welded in a horizontal position.

### **SHEEP HANDLER INTEGRATION**

Yard designs to work with Clipex handles & drafters.

### **PANEL & CLAMP SYSTEM**

Minimising on site welding for increased life.

### **CONCRETED POSTS**

Rock solid heavy duty end posts.

### **CUSTOMISED DESIGNS**

We have our own in house draftsman team.

### **TURNKEY INSTALLATION**

We provide turnkey options for all permanent yards.



## SEMI-PERMANENT SHEEP YARDS

The Clipex semi-permanent sheep yards are extremely strong and durable. Made from high quality steel and cnc precision cut jigs. All sheep hurdles include 16mm pins. They also have an extended foot plate with a hole which the pin can be put through or used to bolt to the ground.

### S400 YARD



- Holds up to 400 Sheep.
- Includes V race with 3 way draft.
- 4 contained areas.
- 189M<sup>2</sup>

### S650 YARD



- Holds up to 650 Sheep.
- Includes V race with 3 way draft.
- 6 contained areas.
- 263M<sup>2</sup>
- Straight drenching race
- Permanent sheep rail.

## INSTALLING A PERMANENT SHEEP YARD



# SHEEP COMPONENTS

## *Gates & Hurdles*

All our Sheep components can be used to create a bespoke Sheep Handling System, whether that involves building into an existing system or creating a fully tailored solution that suits your farms requirements. We can also create any gate or hurdle to match the Clipex range to finish a bespoke system. If designing a bespoke system using the Clipex hurdles is something you are interested in, please get in touch by phoning us on 01361 883245 or emailing [enquiries@thorburngroup.co.uk](mailto:enquiries@thorburngroup.co.uk).



## **BENEFITS OF CLIPEX SHEEP HURDLES**

### **OVAL RAIL PANELS**

Premium quality oval rail sheep hurdles.

### **PREMIUM MANUFACTURING**

All welds are welded in a horizontal position.

### **GALVANISED**

Hot Dip Galvanised as standard.

### **INCLUDED HEAVY PINS**

16mm pins are used on all hurdles and gates.

### **ZINC PAINTED WELDS**

All welds are coated with a heavy zinc based coating.

### **HEAVY DUTY CONSTRUCTION**

Utilising high grade premium steel with 5mm lugs.



**SCAN THE QR CODE TO HEAD TO THE WEBSITE TO VIEW THE FULL RANGE OF SHEEP COMPONENTS.**







**SHEEP GATE IN FRAME WITH SLAM LATCH**



**SHEETED SHEEP HURDLE**



**SHEEP HURDLE**

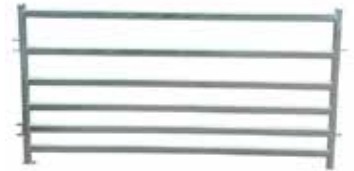

**SHEEP HURDLE**



**SHEEP HURDLE ADAPTER POST**



**RACE GATE**



**DOUBLE RACE GATE**



**SHEEP MAN GATE**



**DOUBLE RACE BOW**



**RACE BOW**



**WORKING RACE**



**WORKING SHEEP CURVE HURDLES**

## V-DRAFT

- V-race with 3 way draft module.
- Hot dip galvanised for longevity.
- Flat packed for easy relocation and freight.
- Permanent or semi-permanent.
- Improve sheep flow and stop sheep walking backwards with our anti-backing bars.
- Ergonomic draft handles.
- Draft gates available separately.
- Long draft gates for ease of drafting.



# EQUINE RANGE

## Gates & Yards



The whole Clipex Equine range was designed for optimum access and safety for when you are in the horse yard. Our equine gates and panels are designed using oval rail to minimise bruising while maintaining strength. The equine gates feature an adjustable top frame adjusting from a height of 2 metres to 2.7 metres.

**THE CLIPEX® EQUINE  
PANELS ARE DESIGNED  
FOR OPTIMUM ACCESS  
AND SAFETY WHEN  
YOU ARE IN THE HORSE  
YARDS.**

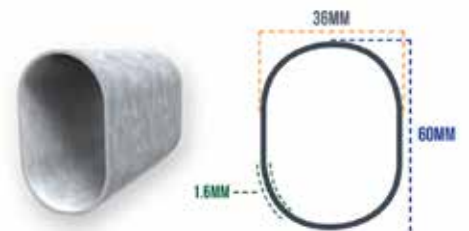

**EQUINE GATES**



**EQUINE PANELS**

# EQUINE YARDS

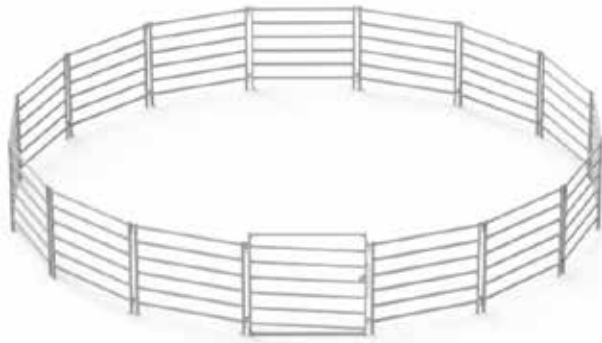

## 11M EQUINE YARD

- Breaking in
- Lunging
- General Purpose
- 15 Panels & 1 Gate
- 11.28m Diameter

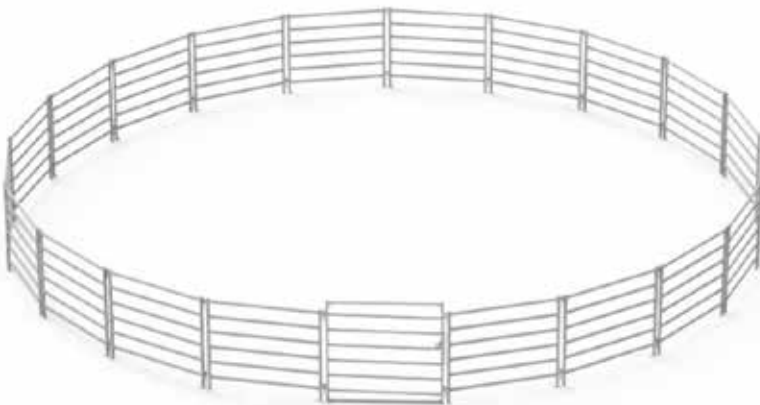

## 14M EQUINE YARD

- Lunging
- Exercise
- General Purpose
- 20 Panels & 1 Gate
- 14.71m Diameter

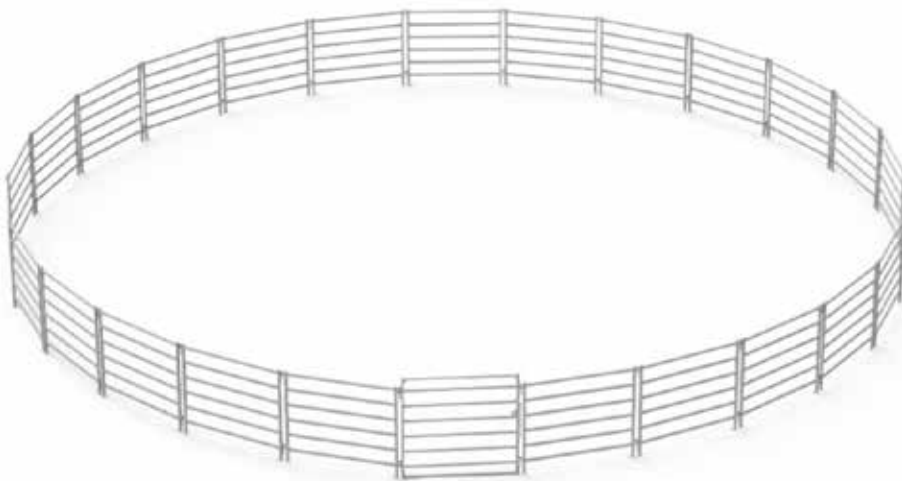

## 18M EQUINE YARD

- Lunging
- Exercise
- 25 Panels & 1 Gate
- 18.18m Diameter

### INNOVATION

We pride ourselves in creating Australia's best, most innovative agricultural products. We focus on creating products with unique, often patented features, designed to make farming easier and more efficient.

### QUALITY

Clipex® sheep equipment is designed and manufactured in house at our own factory.

### COATINGS

All Clipex Animal Handling Solutions incorporate hot dip galvanising to ensure guaranteed performance and longevity. Hot dip galvanising is the pinnacle of today's steel coatings.



## CALL

01361 883245

## EMAIL

enquiries@thorburngroup.co.uk

## ONLINE

www.thorburngroup.co.uk

## VISIT

Thorburn Group, Unit 1, Duns  
Industrial Estate, Duns, TD11 3HS

## FOLLOW

@thorburngroup

