

STORTH

EXPERTS IN SLURRY MANAGEMENT



PUMP IT



Storth have worked hard with the end user to develop a suitable range of Slurry Pumps which will aid Slurry Management on every farm allowing us to provide the right Pump solution every time.

High Performance Slurry Pumps

Specialist Manufacturers of
Slurry Handling Equipment



STORTH
Stoneleigh Park, Station Road,
Holme, Nr Carnforth, Lancashire, LA6 1HR.

Tel: 0044 1524 781 900

Email: sales@storthmachinery.co.uk



Manufactured in the UK

www.storthmachinery.co.uk

Superjet Static 5" & 6" (no agitator)

The Storth Superjet Static (no agitator) Pump is a PTO driven static pump, ideal for use in a reception tank to pump slurry to the slurrystore. The heavy duty, fully galvanised frame ensures long-lasting performance from this machine. Slurry is delivered directly from the impeller drum to the male bauer discharge fitting (as per cover page).

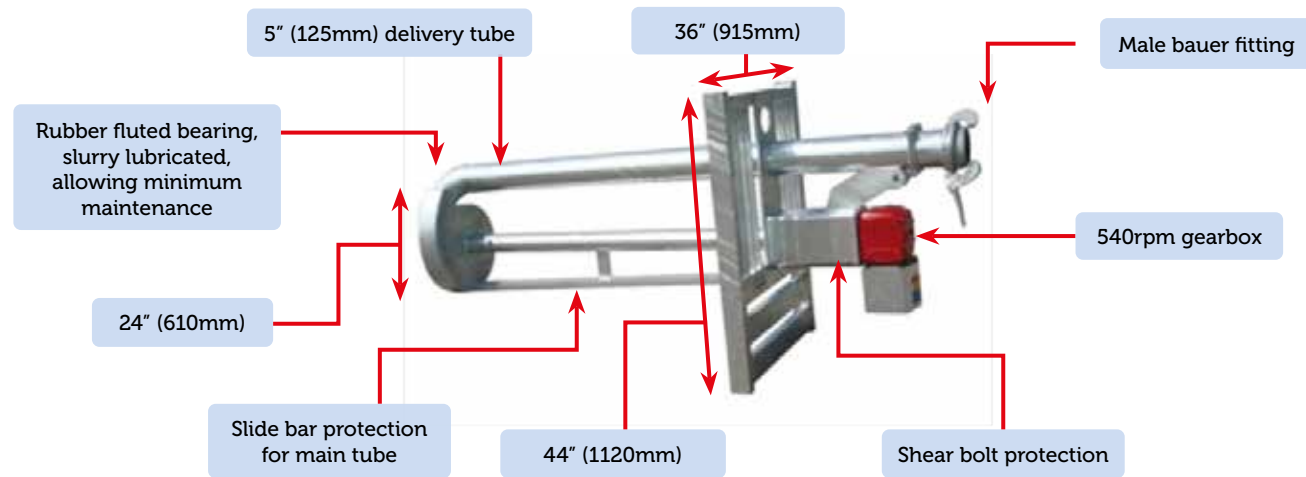

Superjet Static 5" & 6" (with agitator)

The Superjet Static (with agitator) Pump is ideal for use when slurry needs agitating in the reception tank before pumping it into the slurrystore. This pump is fitted with an under surface agitator to the main delivery tube to divert the slurry, causing a high pressure jet agitation. Moving a handle at the pump head diverts slurry up to the male bauer discharge fitting (standard) (as per cover page).

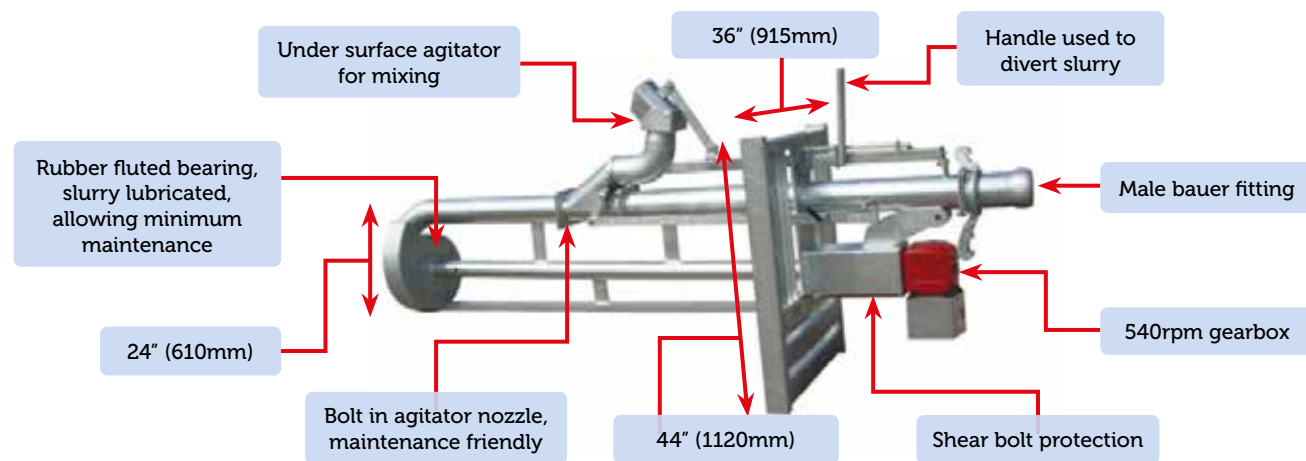

Technical Details

- 540rpm gearbox
- Fully galvanised
- 6 blade impeller, 360mm x 100mm

5" (125mm)

- 60-70hp required
- 5" (125mm) discharge pipe
- 2500 gallons (11,365L) mixing capacity per minute

6" (150mm)

- 100-120hp required
- 6" (150mm) discharge pipe
- 4500 gallons (20,475L) mixing capacity per minute

Lengths available from 5ft (1.5m) up to 16ft (5m). Lengths are measured in 1ft (300mm) increments.

Superjet 2-Point Linkage

The Superjet 2-Point Linkage Pump is a high specification design as is the Superjet 3-Point with quick attachment to the link arms. This machine has a high capacity output with options of 5" and 6" pipework. This machine will need to be placed into position before attaching the PTO shaft. The PTO shaft must be disconnected before moving the machine to different tanks. Full hydraulic movement is also available on all functions from the tractor seat.

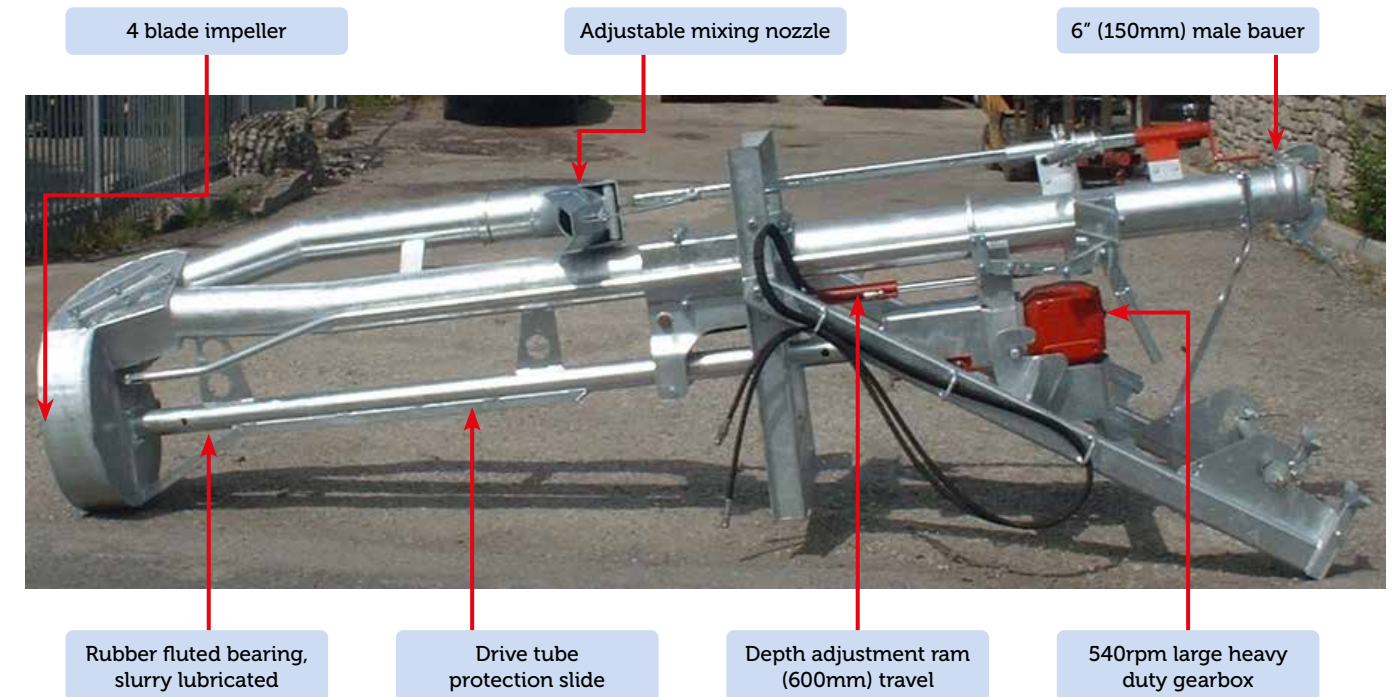

Technical Details

- Fully galvanised
- Hydraulic ram allowing 600mm travel on the depth
- 4 blade impeller, 430mm x 150mm
- 540rpm Large heavy duty gearbox
- Full hydraulic on all functions available

5" (125mm)

- 80-100hp required
- 5" (125mm) discharge pipe
- 3000 gallons (13,638L) mixing capacity per minute

6" (150mm)

- 100-120hp required
- 6" (150mm) discharge pipe
- 4500 gallons (20,457L) mixing capacity per minute

Models Available: 6-8ft (1.8-2.4m) length • 8-10ft (2.4-3.0m) length • 10-12ft (3.0-3.6m) length

Pump Accessories

As all applications of slurry management are not all the same, Storth have developed a range of accessories to fit all our Slurry pumps.

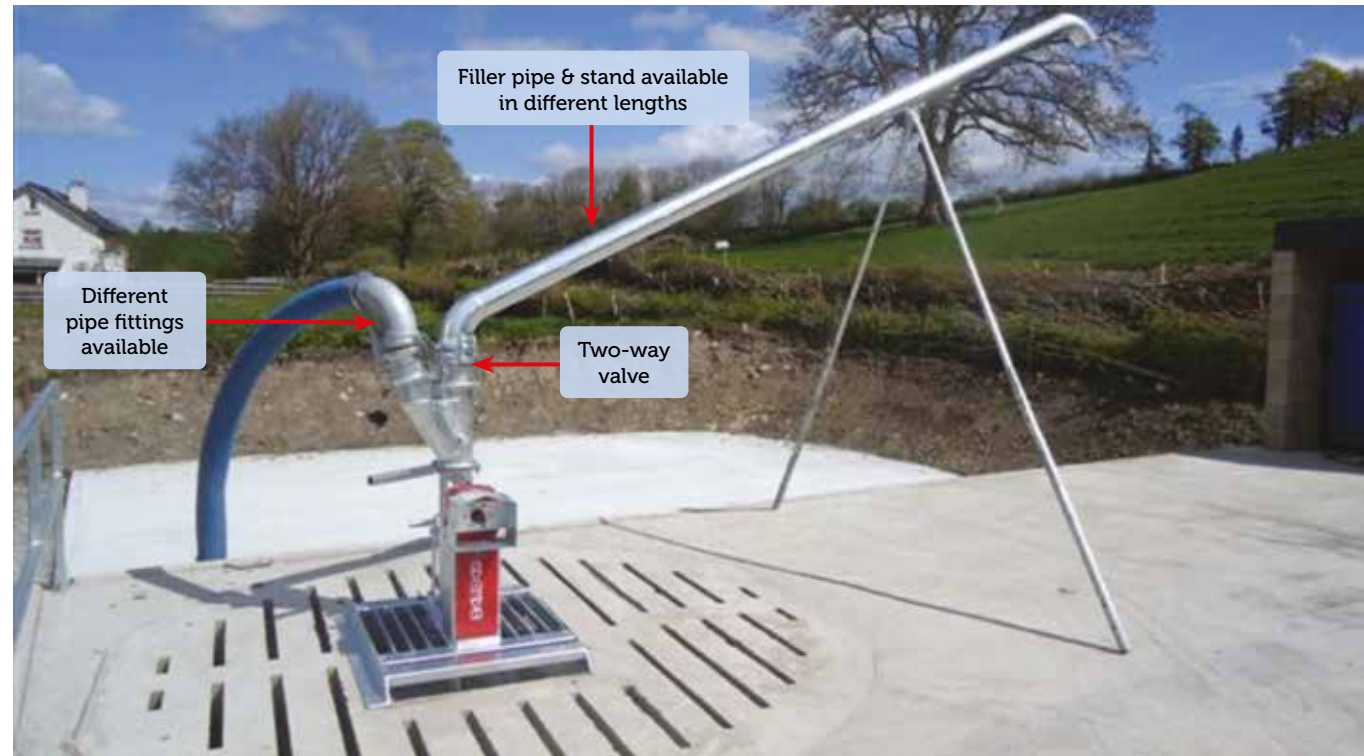

Re-Circulation Pump

The 6" Re-Circulation pump is used to enable the mixing of above ground storage tanks without the need for a reception tank. The slurry enters the re-circulation pump from a head pressure of slurry entering the impeller housing with a 1,000rpm input. The machine will discharge at 3,000gpm.



Technical Details

- Fully galvanised
- 3-point linkage frame

Superjet 3-Point Linkage 5" & 6"

The Superjet 3-Point Linkage is a high capacity pump with options of 5", 6" and 8" pipe work. Fitted with a high capacity drum, the Superjet 3-Point Pump enables high volumes of slurry to be moved long distances. The under surface agitator will give incredible agitation prior to pumping. When moving this pump from tank to tank the PTO can be left attached to the tractor and machine. This extra option is full hydraulic movement on all functions to allow full control from the tractor seat.

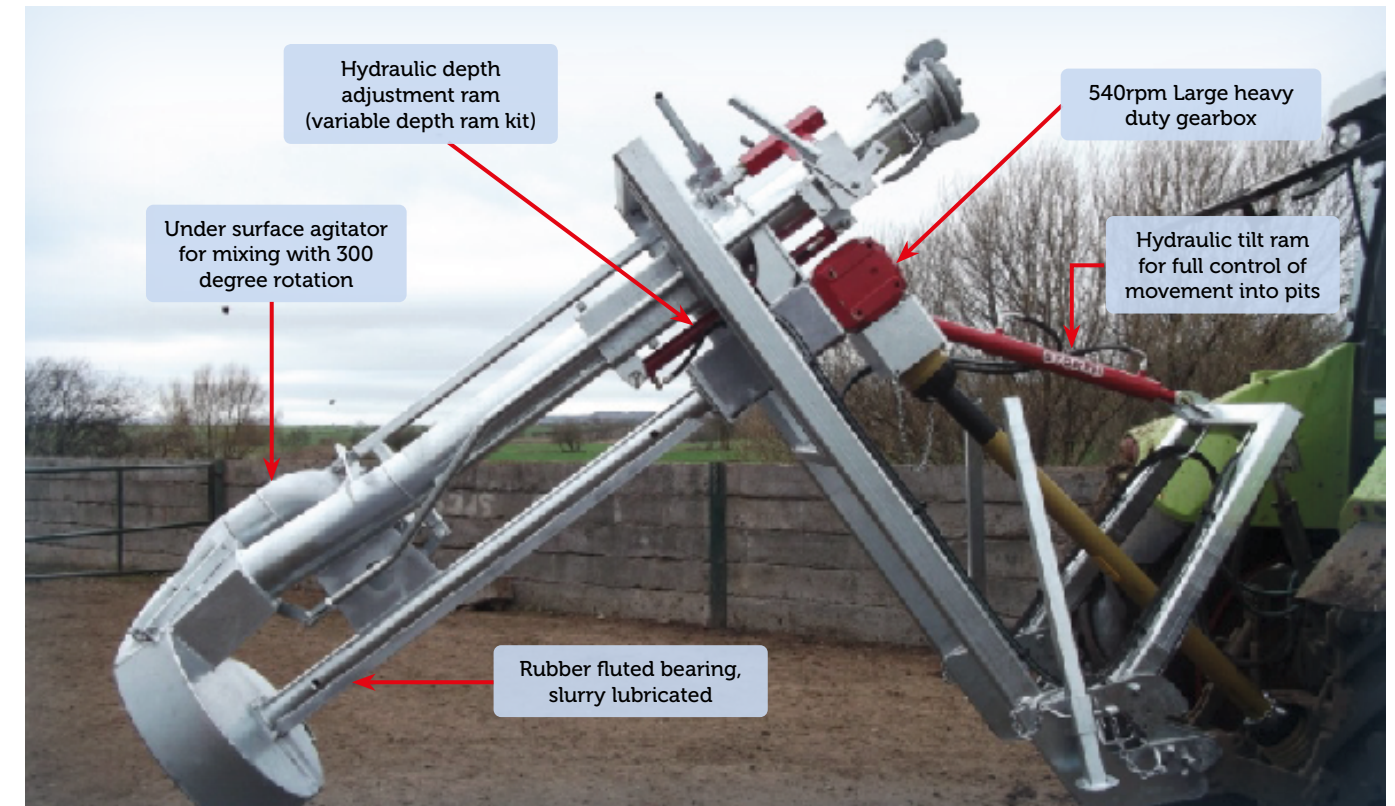

Technical Details

- Variable depth ram kit available to mix different tank depths
- 4 blade impeller
- 540rpm large heavy duty gearbox
- Full hydraulic on all functions available
- PTO included

Models Available

Lengths available from 6ft (1.8m) up to 12ft (3.6m). Lengths are measured in foot (300mm) increments.

Or models with variable depth Ram Kit

- 6-8ft (1.8-2.4m) length
- 8-10ft (2.4-3.0m) length
- 10-12ft (3.0-3.6m) length

Superjet 3-Point Linkage 8"

The Superjet 3-Point Linkage 8" Pump is the ultimate mixer pump with unrivalled performance and high quality construction which allows this machine to satisfy the larger farmer and contractor's slurry problems. All models are all fully hydraulic controlled from the tractor seat, hydraulic tilt ram, hydraulic depth adjustment, hydraulic motor for rotating the mixer nozzle and a hydraulic ram for moving the mixer nozzle flap up and down. All of these functions can be run from a minimum of two double acting services from the tractor.

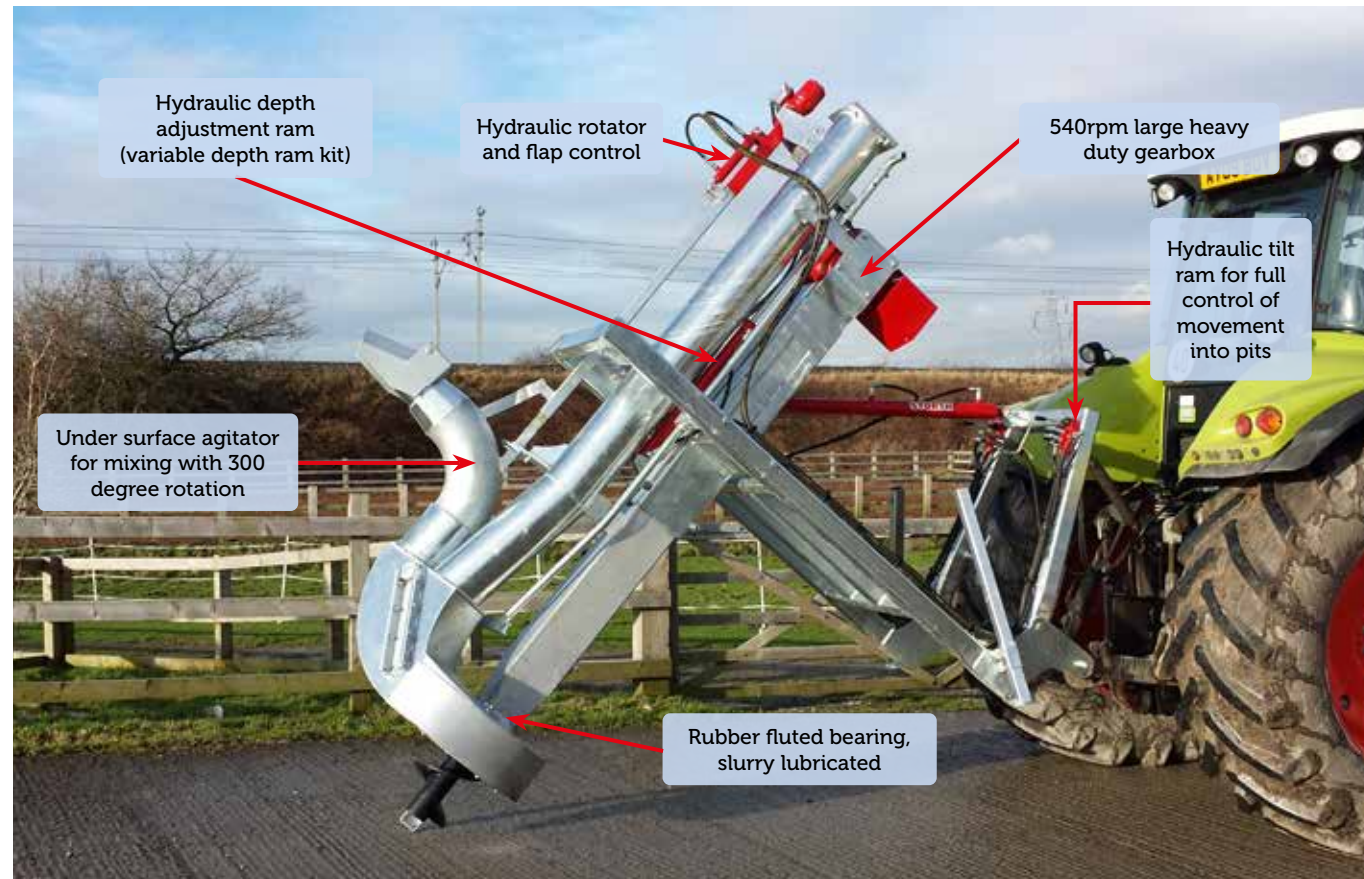

5" (125mm)

- 80-100hp required
- 5" (125mm) discharge pipe
- 3000 gallons (13,638L) mixing capacity per minute

6" (150mm)

- 100-120hp required
- 6" (150mm) discharge pipe
- 4500 gallons (20,457L) mixing capacity per minute

8" (175mm)

- 160-180hp required
- 8" (175mm) discharge pipe
- 6500 gallons (29,549L) mixing capacity per minute



Electric Pumps

Storth have developed a range of electric driven pumps to enable the farmer to manage slurry automatically without the use of a tractor. Storth Electric Pumps all require 3 phase electric and are available in different motor sizes, dependent on the application. Our Electric Pumps can be set up on float switches to allow the pump to start and stop automatically when the slurry reaches a certain level.

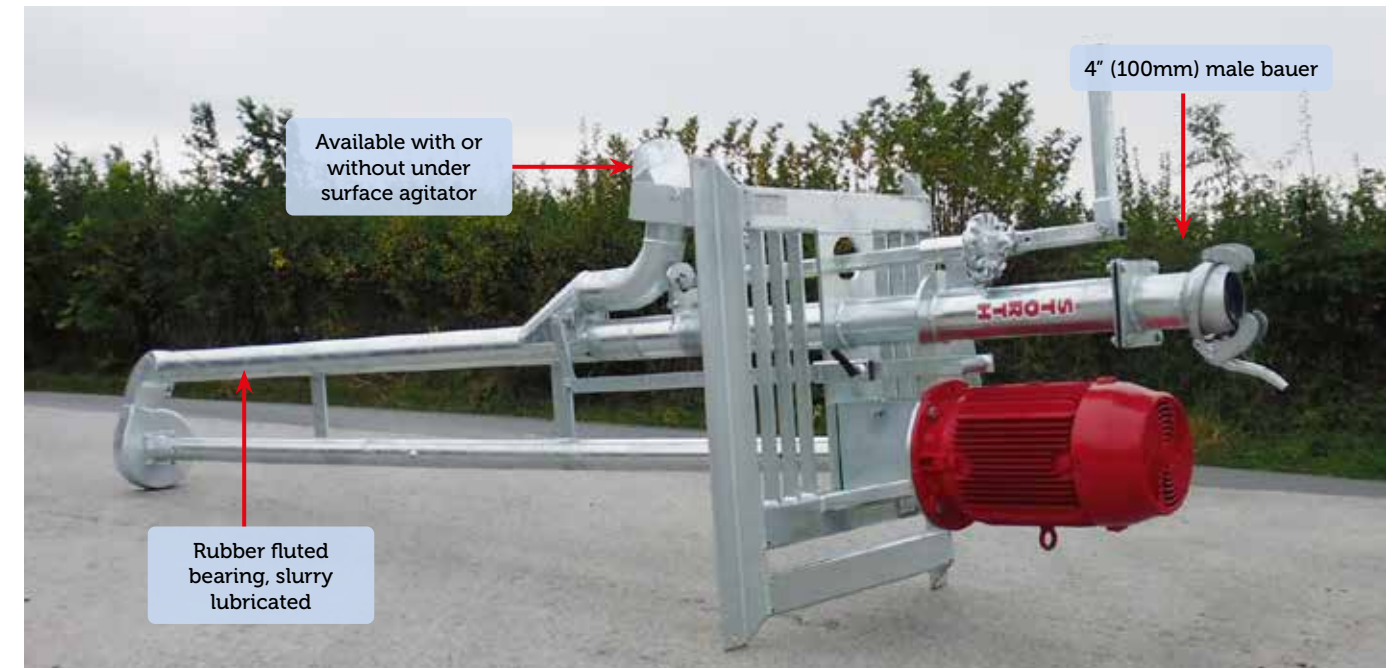

Technical Details

- 3 phase electric is required
- 4" & 5" (100mm & 125mm) discharge pipe
- Fully galvanised
- Available with or without the under surface agitator
- Supplied with Storth control panel

Models Available

- Lengths available from 6ft (1.8m) up to 16ft (5m).
- Different sizes of motor available on all lengths: 11kw, 15kw, 18.5kw & 22kw.

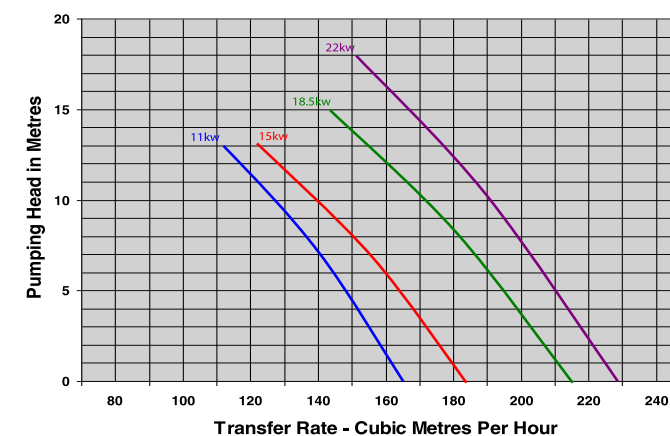

STORTH

EXPERTS IN SLURRY MANAGEMENT

For additional information and advice
please contact your Storth representative

Andrew Howatson

07393 149 598

andrew@storthmachinery.co.uk

Sales Manager

Neil Robinson

07887 855 048

neil@storthmachinery.co.uk

Gary Morland

07919 563 796

gary@storthmachinery.co.uk

Geraint Williams

07464 548 576

geraint@storthmachinery.co.uk

Fi Callaway

07818 053 159

fi@storthmachinery.co.uk

STORTH
EXPERTS IN SLURRY MANAGEMENT

Stoneleigh Park, Station Road,
Holme, Nr Carnforth, Lancashire, LA6 1HR.

Manufactured in the UK

Tel: 0044 1524 781 900

Email: sales@storthmachinery.co.uk

Global Sales

Julian Lopez

+44 (0) 7384 258 916

export@storthmachinery.co.uk



www.storthmachinery.co.uk

V2207