

BOOTH PANEL SPECIFICATION

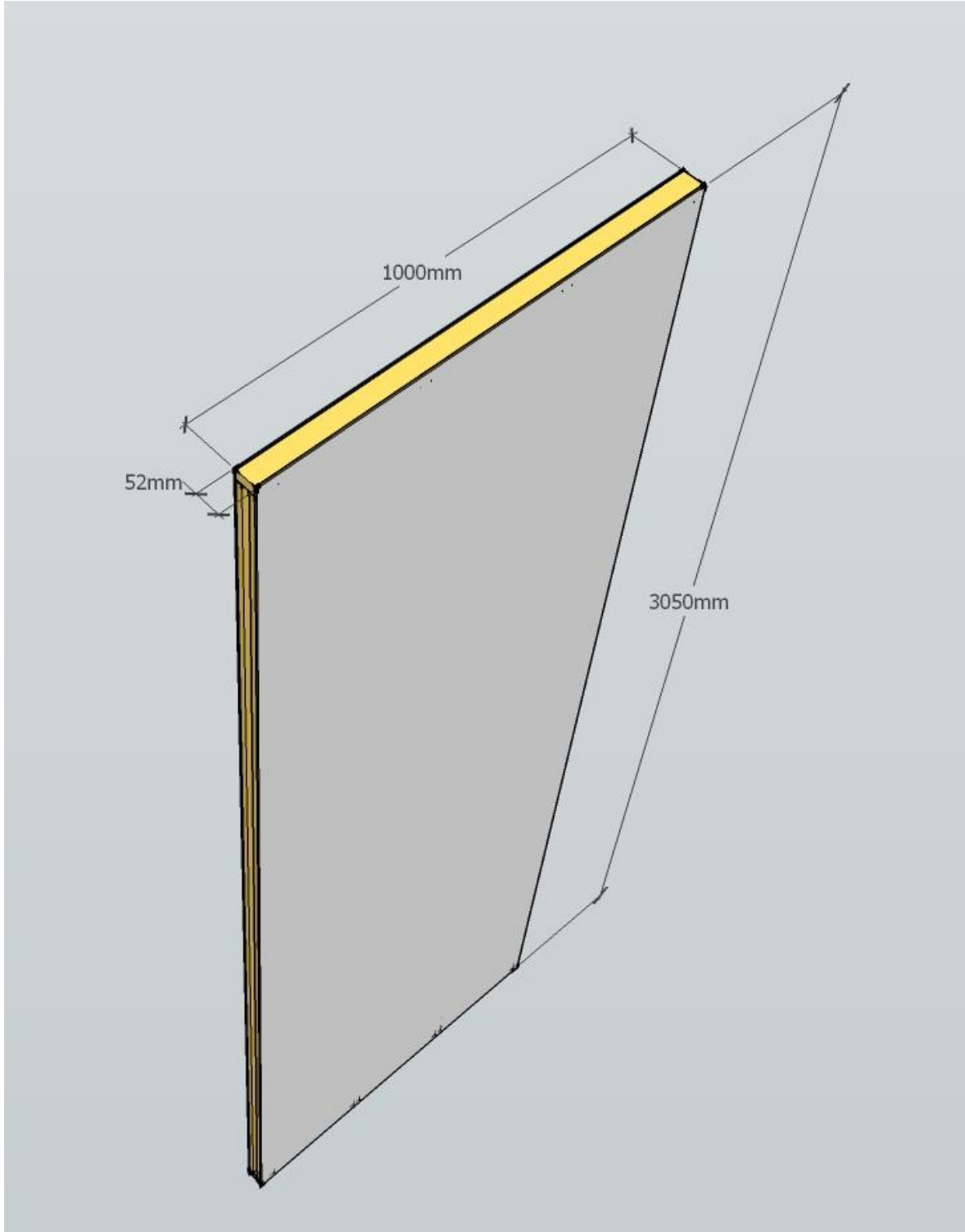

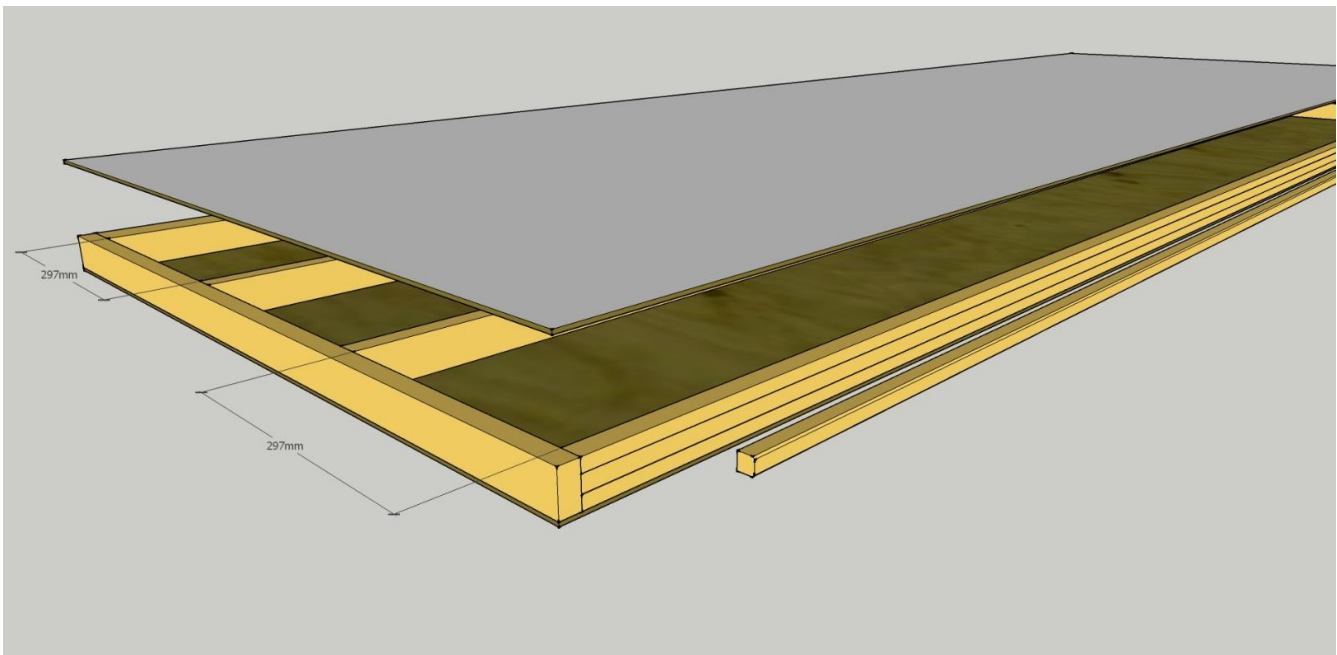
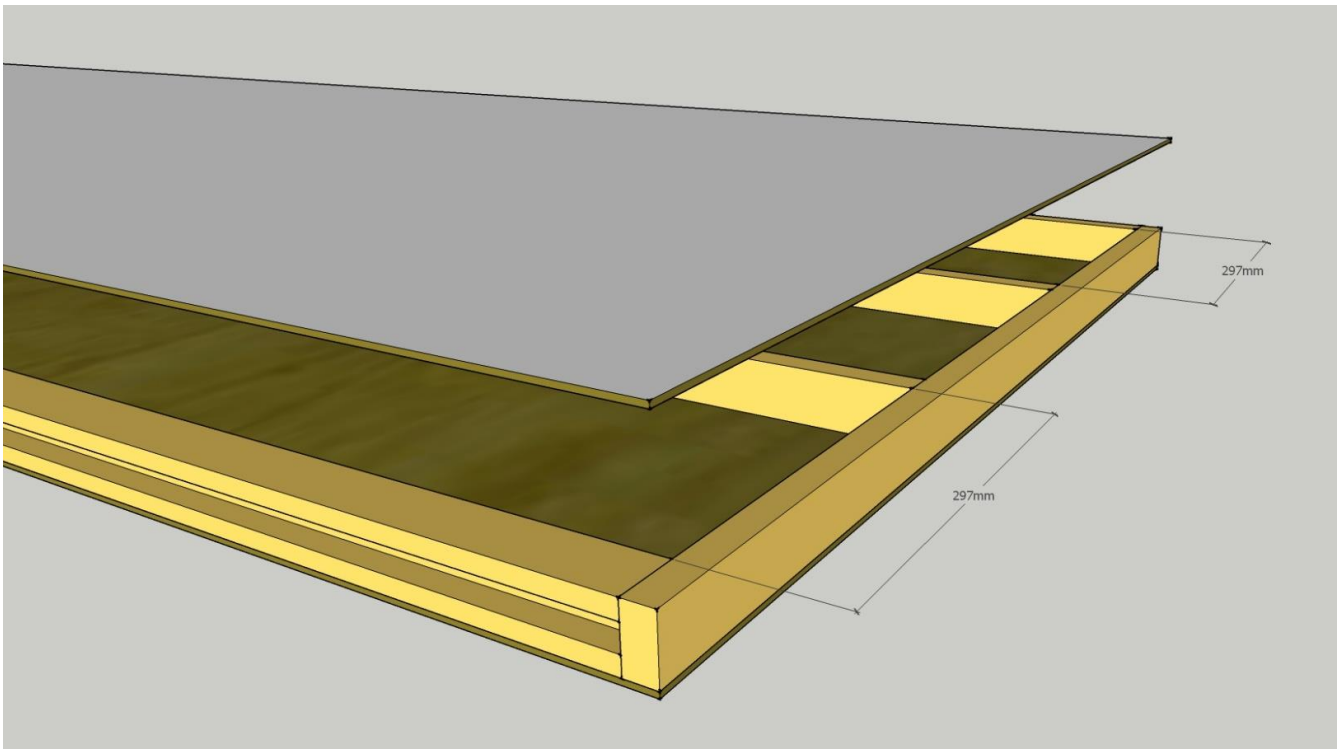

PANEL COMPONENTS OVERVIEW

Grooved external uprights – 3006mm soft wood timbers on the long sides of the Panels. The 1mm groove is for positioning of tongue

Internal uprights and cross members

-two 3006 mm pieces for reinforcing inside of the panel

-two 1000mm pieces on the top and the bottom of the panel

Tongue – 2700mm x 17mm x 17mm wide with 2 chamfered edges with 5 evenly spaced predrilled countersunk 4.5 mm diameter holes used to join the panels together

.Fire retardant ply – two sheets at 3050mm x 1000mm x 3.6mm