



Introducing the
EchoStar Mobile LoRaWAN[®]
Satellite Relay EM-SR



EchoStar Mobile LoRaWAN® Satellite Relay EM-SR

The EM-SR LoRaWAN® Satellite Relay from EchoStar Mobile is the most cost-efficient solution to fill the gaps in your LoRaWAN® network.

It's designed to be used in areas where there is no direct view of the sky for connecting to satellite, providing a solution for sensors and devices in those locations to be connected to the network. It works by receiving data from sensors via terrestrial wireless and pushing data forward to the satellite.



How EM-SR works

The EM-SR is a device that forwards uplink LoRa® data received from trusted end-devices. Likewise, the relay receives downlink LoRa® frames from the network server and forwards them to the appropriate end-devices.

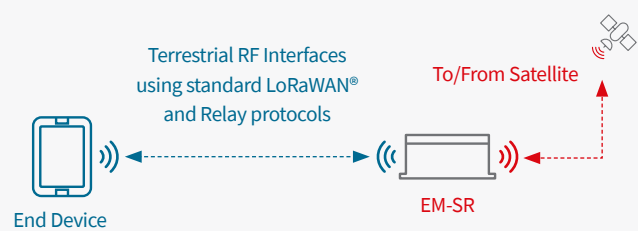

The EM-SR, a plug-and-play device, offers a practical, reliable and cost-effective way to fill the gap for sensors located at the edge of the RF coverage provided by conventional terrestrial gateways.

This could be the case for sensors located deep indoors, in basements or even inside metallic cabinets. A typical example is about smart metering use cases, where deploying an EM-SR eliminates the need for costly drive-by operations to collect meter readings in hard-to-reach spots.

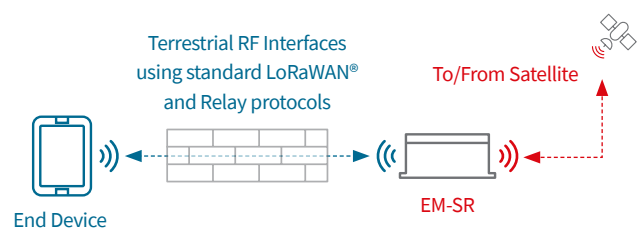

The EM-SR is particularly useful in zones where, from a cost or operational standpoint, it is not practical to add terrestrial conventional gateways, either due to lack of power supply, visibility or backhaul options.

The EM-SR is battery-powered and can use energy-harvesting solutions for long term deployments.

End-devices served by the EM-SR use class A mode.

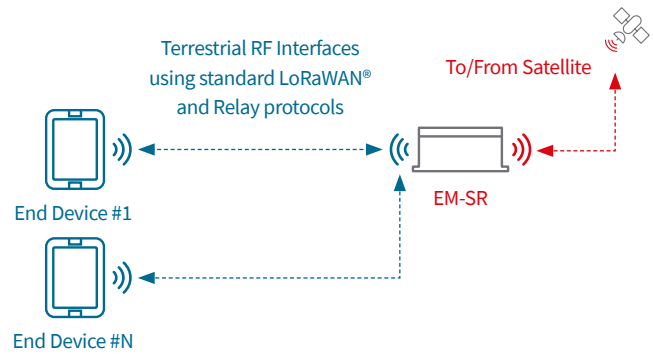

End-devices operating behind the EM-SR must support the relay stack in their software which allows them to use the standard radio protocol defined in LoRaWAN® TS011.



Capabilities

The EchoStar Mobile EM-SR LoRaWAN® Satellite Relay is a managed solution which includes both EM-SR management and FUOTA capabilities.

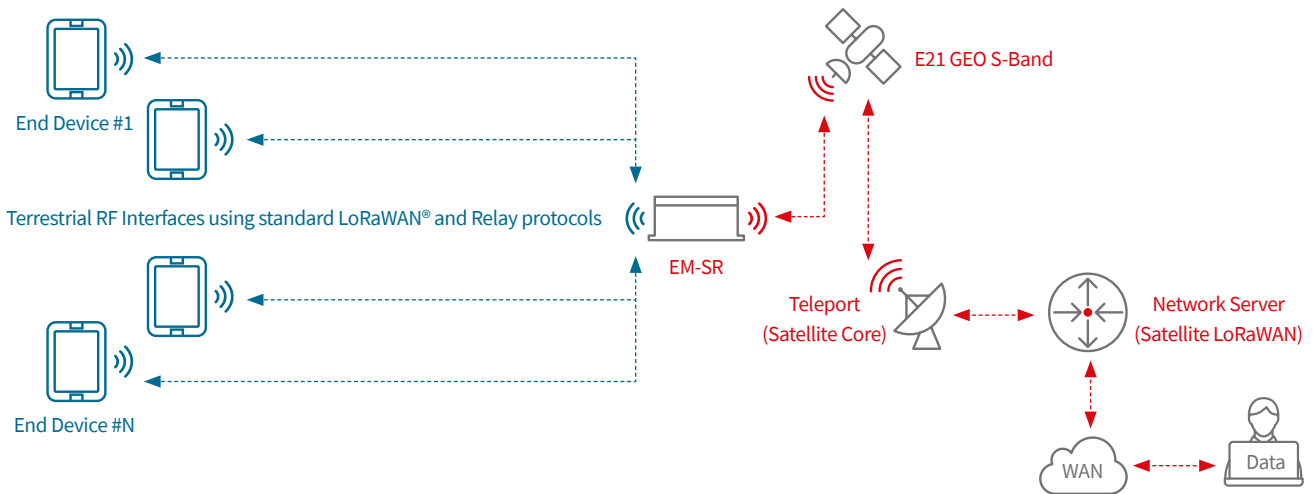

Benefits

The EchoStar Mobile EM-SR LoRaWAN® Satellite Relay brings the following benefits.

Hybrid Network Deployment	Remote Areas Deep Penetration	Lower Deployment & Ops Cost	Firmware Update Over The Air	Long Battery Life	Easy to Scale	Standards Compliance
100% Coverage	Extended Range & Underground	Low Total Cost of Ownership	Updates and Security Control	Long-Term Deployments	Enabling Additional Use Cases	LoRaWAN® TS011 Ecosystem



Want to know more?



[EchoStarMobile.com](https://www.EchoStarMobile.com)



+44(0)1908 422900

© 2024 EchoStar Mobile Ltd. All rights reserved. The EchoStar Mobile logo is a registered trademark of EchoStar Mobile Ltd and its affiliates. All other logos and trademarks are the property of their respective trademark owners.

About EchoStar: EchoStar Corporation (NASDAQ: SATS) is a premier global provider of satellite communication solutions. Headquartered in Englewood, Colo., and conducting business around the globe, EchoStar is a pioneer in secure communications technologies through its Hughes Network Systems and EchoStar Satellite Services business segments. For more information, visit [EchoStar.com](https://www.EchoStar.com). Follow [@EchoStar](https://twitter.com/EchoStar) on Twitter.