

HIGH SCHOOL (WESTERN REGION)

2015

TRIAL
HIGHER SCHOOL CERTIFICATE
EXAMINATION

Mathematics General 2

- **General Instructions**
- Reading time – 5 minutes
- Working time – $2\frac{1}{2}$ hours
- Write using black or blue pen
Black pen is preferred
- Board-approved calculators may be used
- A formulae and data sheet is provided at the back of this paper
- In Questions 26 – 30, show relevant mathematical reasoning and/or calculations

Total Marks – 100

Section I Pages 2 – 12

25 marks

- Attempt Questions 1 – 25
- Allow about 35 minutes for this section

Section II Pages 13 – 40

75 marks

- Attempt Questions 26 – 30
- Allow about 1 hour and 55 minutes for this section

Section I

25 marks

Attempt Questions 1 – 25.

Allow about 35 minutes for this section.

Use the multiple-choice answer sheet for Questions 1 – 25.

1. Find the value of $\frac{2(v-ut)}{t^2}$ when $v = 30$, $u = 4$ and $t = 3$.
(A) -4
(B) -2
(C) 2
(D) 4
2. David is playing a card game and has 12 cards in his hand.
He has to give two cards to Kayla.
How many different combinations of two cards could he give to her?
(A) 24
(B) 48
(C) 66
(D) 132
3. Theo works as a fitter in a factory and is paid normal rates of \$46.50 per hour for a 35 hour week, then time and a half for any overtime.
What would he earn for a week where he worked 42 hours?
(A) \$488.25
(B) \$1 953.00
(C) \$2 115.75
(D) \$2 929.50

4. Cynthia calculated the average speed of her 160 km train journey to Sydney to be 50 km/h. She then realised that the time that she used in the calculation was 42 minutes more than the actual time of the journey.

What was the correct average speed of the train?

- (A) 41 km/h
- (B) 45 km/h
- (C) 55 km/h
- (D) 64 km/h

5. The stamp duty for a vehicle is calculated as follows:

3% of the value of a vehicle up to \$45 000, plus 5% of the value of the vehicle over \$45 000.

What is the stamp duty payable on a vehicle valued at \$57 000?

- (A) \$600
- (B) \$1 350
- (C) \$1 950
- (D) \$2 850

6. Calculate the area of the sector shown, correct to 4 significant figures.

- (A) 107.2 cm²
- (B) 132.5 cm²
- (C) 201.1 cm²
- (D) 804.2 cm²

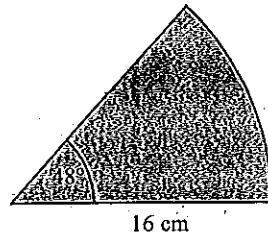

7. Louise is prescribed 900 mg per day of a drug called Londane. Londane is available in tablets which each contain 200 mg. If she is to take the Londane twice a day, how many tablets should Louise take each time?

- (A) $1\frac{3}{4}$ tablets.
- (B) $2\frac{1}{4}$ tablets.
- (C) $2\frac{1}{2}$ tablets.
- (D) $2\frac{3}{4}$ tablets.

8. Louisa has \$20 000 to invest for a period of three years. She has decided to invest the money in a bank account. She has narrowed her investment options to four options, all of which have no bank fees.

Which investment will earn her the most in interest?

- (A) Bank A offers 6.6% p.a. simple interest.
- (B) Bank B offers 6.5% p.a. interest compounding annually.
- (C) Bank C offers 6.4% p.a. interest compounding quarterly.
- (D) Bank D offers 6.0% p.a. interest compounding monthly.

9. The graph below illustrates the pricing for an individual voice call on the Lo-Cost Phone plan. Yesterday Dean made four calls which lasted for 5 minutes, 3 minutes, 2 minutes and 9 minutes respectively.

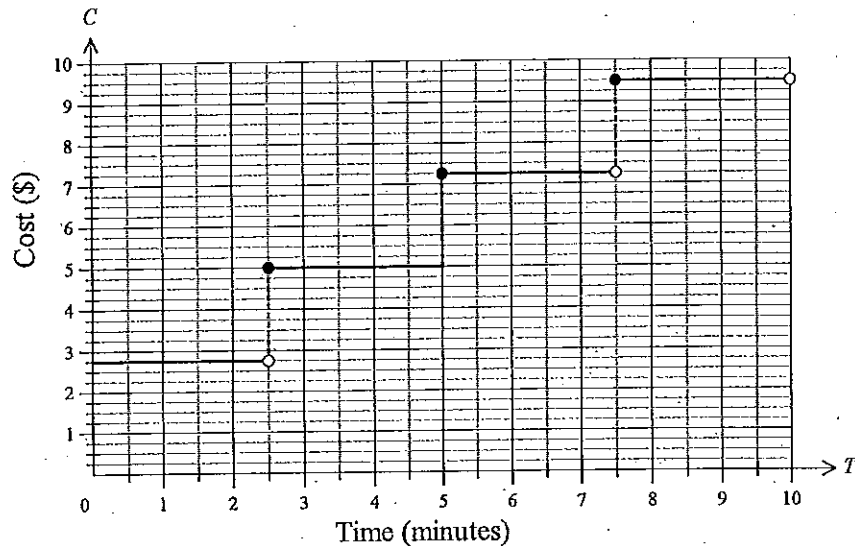

What was Dean charged in total for the four calls?

- (A) \$19.00
 (B) \$19.50
 (C) \$22.25
 (D) \$24.50
10. Calculate the size of angle F, correct to the nearest degree.

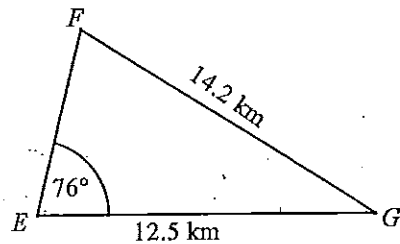

- (A) 31°
 (B) 41°
 (C) 49°
 (D) 59°

11. Jo draws a scatterplot to compare Hand Span (s) and Reaction Time (t) and notices a linear relationship. She calculates that there is a correlation coefficient of $r = -0.8$. She also calculates the results below for the means and standard deviations.

	Horizontal (s) axis	Vertical (t) axis
	Hand Span (mm)	Reaction Time (ms)
Mean	165	820
SD	25	324

What is the gradient of the least-squares line of best fit (correct to 3 s.f.)?

- (A) -10.4
 (B) -4.0
 (C) 4.0
 (D) 10.4
12. Jason had a gross weekly income of \$1 615.40 for all of the last financial year. Use the table below to calculate his income tax due for the financial year, if he had allowable deductions of \$3 240.00.

Taxable income	Tax on this income
0 – \$18,200	Nil
\$18,201 – \$37,000	19c for each \$1 over \$18,200
\$37,001 – \$80,000	\$3,572 plus 32.5c for each \$1 over \$37,000
\$80,001 – \$180,000	\$17,547 plus 37c for each \$1 over \$80,000
\$180,001 and over	\$54,547 plus 45c for each \$1 over \$180,000

- (A) \$17 828
 (B) \$20 226
 (C) \$31 080
 (D) \$84 000

13. Katie is driving at a speed of 110 km/h in a zone where the speed limit is 100 km/h. How many more metres does she travel in each second, compared to travelling at the speed limit?

- (A) 1.44 metres
 (B) 2.78 metres
 (C) 3.22 metres
 (D) 27.78 metres

14. A field diagram has been drawn from an offset survey. Find the area of the field.

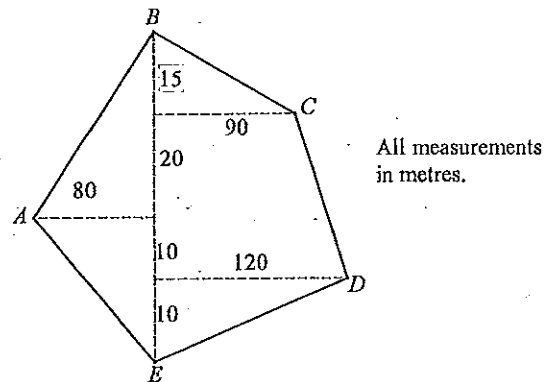

- (A) 6 625 m²
 (B) 7 225 m²
 (C) 7 300 m²
 (D) 8 825 m²

15. A survey was done of the incomes of 2 000 full time employed adults. The incomes were normally distributed with a mean of \$1 516 with a standard deviation of \$145. Approximately how many individuals from those surveyed had an income below \$1 226?

- (A) 50
 (B) 100
 (C) 200
 (D) 400

16. A straight line graph has a gradient of -2 . A point on the line has a y value of -8 when $x = 4$.

What is the equation of the line?

- (A) $y = -2x$
 (B) $y = -2x - 8$
 (C) $y = 2x$
 (D) $y = 4x - 8$

17. Express $\frac{24a^4d^3}{-6d^2e^3}$ in simplest form.

- (A) $-\frac{4a^4d}{e^3}$
 (B) $-\frac{a^4}{4de^3}$
 (C) $-\frac{4a^4}{de^3}$
 (D) $-\frac{a^4d}{4e^3}$

18. Jose collects data on class sizes in his school. The results are shown in the frequency table below.

Class Sizes at Gilmore High

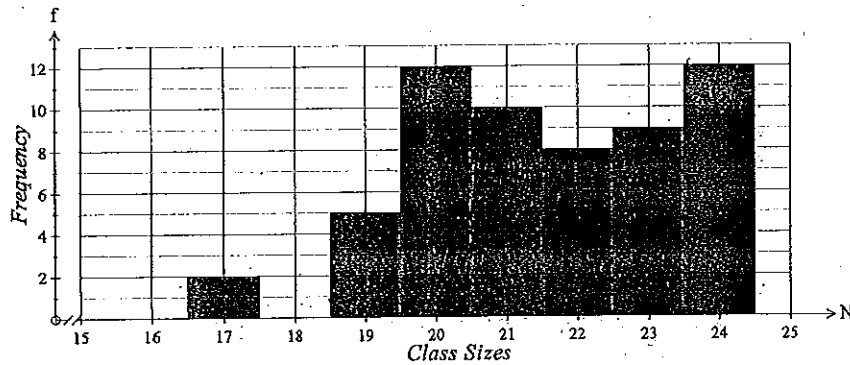

What are the mean and standard deviation of the class sizes?

- (A) Mean = 20.5; Standard deviation = 1.8
 (B) Mean = 20.5; Standard deviation = 2.3
 (C) Mean = 21.6; Standard deviation = 1.8
 (D) Mean = 21.6; Standard deviation = 2.3
19. In a game of chance, a player outlays \$3 and a single die is rolled. The table shows the returns for the different outcomes.

Number on die	Result
	Break even.
	Win \$2
	Win \$6
	Lose \$3.

What is the financial expectation of the game, to the nearest cent?

- (A) -\$0.50
 (B) -\$0.17
 (C) \$0.00
 (D) \$0.17

20. Mike has an apple orchard and employs six workers on a piecework basis. He has drawn up the spreadsheet below to calculate the pay due for each day.

	A	B	C	D	E	F
1		Pay Calculations For Piecework				
2	Name	Section	Number of Baskets	Hours Worked	Rate per Basket	Pay Due
3	Terry	Grannys	8	9.5	\$22.50	\$180.00
4	Ursula	Grannys	7	8.5	\$22.50	\$157.50
5	Vince	Gala	9	8.5	\$20.50	\$184.50
6	Wendy	Pink Lady	9	9	\$19.50	\$175.50
7	Xavier	Delicious	10	9	\$18.50	\$185.00
8	Yvonna	Pink Lady	8	7	\$19.50	\$156.00
9			Average Hours Worked	8.6	Total Payroll	\$1,038.50
10			Average Baskets Picked	8.5	Average Daily Pay	\$173.08

Mike changes the contents in a cell which causes changes in cells F4, F9 and F10.

Which cell could he have changed?

- (A) A4
 (B) B4
 (C) D4
 (D) E4
21. John buys an external hard drive with a capacity of 2.5 terabytes. The songs in John's digital music library have an average size of 3.2 megabytes. How many of these songs could he fit on the external hard drive?
- (A) 800
 (B) 25 600
 (C) 819 200
 (D) 838 860 800

22. The graph below shows the amount outstanding on a loan of \$500 000 with a term of 400 months.

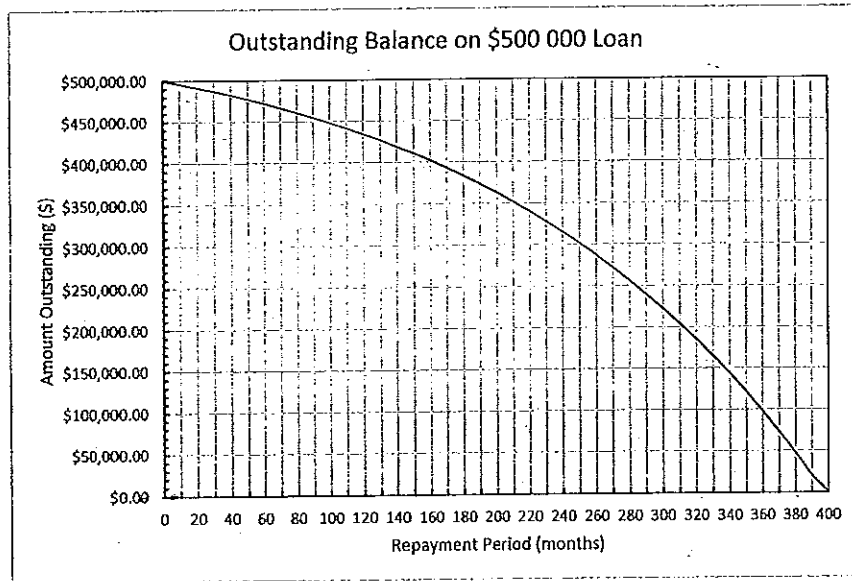

After how many months has half of the amount borrowed been paid back?

- (A) 200 months
 (B) 280 months
 (C) 281 months
 (D) 284 months
23. A scale drawing of a dam on a property is shown.
 The average depth of the dam is 1.8 metres.
 What is a reasonable estimate for the volume of the dam?
- (A) 150 m^3
 (B) 250 m^3
 (C) 350 m^3
 (D) 500 m^3

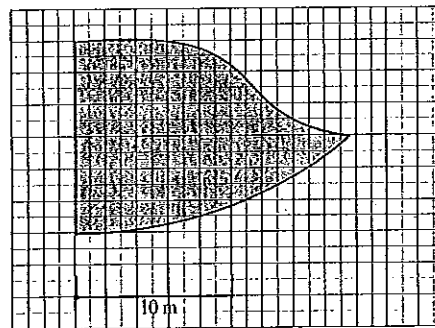

24. Julia used the capture recapture method to estimate the number of mice in a city building. On one day she captured 60 mice and tagged and released them. A week later she captured another 54 mice and of these, 24 were tagged. What is her estimate of the population of mice in the building?
- (A) 114 mice
 (B) 135 mice
 (C) 140 mice
 (D) 270 mice
25. To obtain a BASIX certificate for a new dwelling, the design must achieve a reduction in energy usage.
 Before the reduction it is assumed that each person living in the dwelling would use enough energy to produce 3,292 kg of CO_2 per year.
 The table below indicates the percentage reduction required.

Energy saving targets					
		Type of Dwelling			
		Detached	Low Rise	Mid Rise	High Rise
Zone of NSW	Zone 1	40%	35%	30%	20%
	Zone 2	35%	30%	25%	15%
	Zone 3	25%	20%	15%	5%

- Rosemary and David are building a low rise dwelling in Zone 2 which will have an expected occupancy of 6 people. How many tonnes of CO_2 would they be expected to save per year for the dwelling?
- (A) 1.0 tonnes
 (B) 5.9 tonnes
 (C) 6.9 tonnes
 (D) 19.7 tonnes

End of Section I

Mathematics General 2

Section II

75 marks

Attempt Questions 26-30

Allow about 1 hour and 55 minutes for this section

Answer the questions in the spaces provided.

Your responses should include relevant mathematical reasoning and/or calculations.

Extra writing space is provided on page 40. If you use this space, clearly indicate which question you are answering.

Class and Teacher

Student Number

Student Name

BLANK PAGE

Please turn over

Question 26 (15 marks)

(a) There are nine members on the Board of Directors of the Community Hospital. From the board, a President, Secretary and Treasurer need to be elected.

(i) How many different arrangements of President, Secretary and Treasurer are possible? 1

.....

.....

(ii) Two members of the board are also elected to be delegates to a medical conference. How many different pairs of delegates are possible? 1

.....

.....

(b) A vase is in the shape of a hexagonal prism, which has cross section shown below.

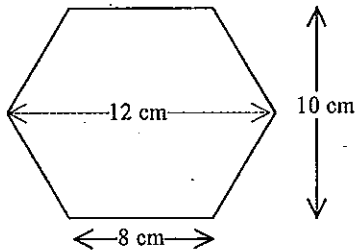

(i) Find the area of the cross section. 1

.....

.....

(ii) The vase is 18 cm tall. Calculate its capacity, to the nearest 10th of a litre, given that 1 cm³ holds 1 ml.

.....

.....

.....

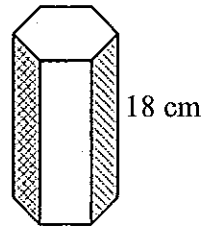

Question 26 continues on page 16

Question 26 (continued)

(c) To collect data on driver fatigue in long distance transport, Kasey goes to a truck stop on the M1 motorway and asks a sample of twenty drivers to fill in a survey.

(i) Outline one reason why this method of obtaining the sample could lead to biased results. 1

.....

.....

(ii) One of the questions on the survey asks: "How long have you been driving since you started your journey or took your last rest break?" 1
What type of data is being collected in this question?

.....

.....

.....

(d) Expand and simplify $4x(2x - 6y) - 3y(4x - y)$. 2

.....

.....

.....

Question 26 continues on page 17

Question 26 (continued)

(e) Jack is on the following mobile phone plan:

\$60 Saver Plan	
Minimum monthly cost \$ 60.00.	
\$100 of voice calls included each month.	Voice calls: Connection fee : \$0.20 Call cost : \$1.10 per minute
1 GB of data included each month.	Data: \$0.20 per MB.
\$40 of SMS included each month.	SMS: \$0.18 each.

(i) In August Jack used an average of 40 MB of data per day. How many MB of data did he use in excess of his included data for the month? 1

.....

.....

.....

.....

(ii) In August he also made 75 voice calls totalling 150 minutes and sent 120 SMS. What was his total cost for August? 2

.....

.....

.....

.....

.....

Question 26 continues on page 18

Question 26 (continued)

(f) Miriam was investigating the effect of lack of sleep on drivers. She collected data on reaction times and compared these to the hours of sleep of the participants. The results are shown on the scatterplot below.

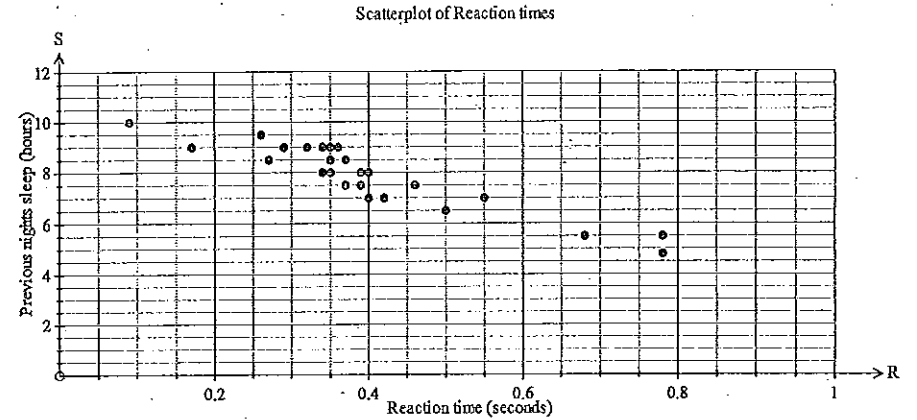

(i) Miriam calculates the least squares line of best fit to have an equation of: $S = -7.5R + 10.8$. 1
Draw the line on the graph above.

.....

.....

.....

(ii) Estimate the reaction time of a person who had 6 hours sleep before the test. 1

.....

.....

.....

Question 26 continues on page 19

Question 26 (continued)

- (g) Charlie buys a new car which is advertised by the car company at a price of \$25 600. In addition he has to pay the following "on road costs": 2

Stamp duty which is 3% of the value of the car
 CTP insurance of \$356.50
 Dealer delivery Fee of \$15.40 per \$1000 or part thereof.
 Registration fee of \$277.00.

What does it cost altogether for Charlie to purchase the car and get it on the road?

.....

End of Question 26.

Question 27 (15 marks)

- (a) Tahlia prepares the budget below to help her plan for an overseas trip. The cost of the trip is \$6 500 and she wants to take \$1 200 for expenses.

	A	B	C	D	E	F
2		Tahlia's Weekly Budget				
3		Income		Expenses		
4		Normal Wages	\$990.00	Rent	\$350.00	
5		Weekend work	\$300.00	Food	\$180.00	
6		Total Income	\$1,290.00	Utilities	\$90.00	
7				Clothing	\$100.00	
8				Other Expenses	\$150.00	
9				Total Expenses	\$870.00	
10				Savings		

- (i) How many weeks will she need to maintain the budget above in order to save enough for the trip and expenses? 1

.....

- (ii) Before she can start on the budget Tahlia loses her weekend work. She decides to divert money from the Other Expenses to Savings to allow her to save for the trip. 1

How much must she divert each week if she wants to save all that she needs for the trip and expenses within a year?

.....

Question 27 continues on page 21

Question 27 (continued)

- (b) Triangle ABC is similar to triangle DEF .

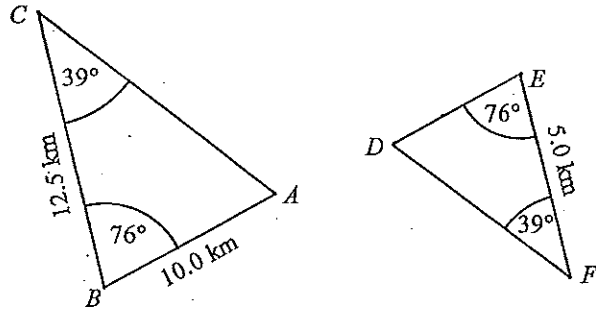

- (i) What is the scale factor for the similar triangles?

.....

- (ii) Calculate the length of DE .

.....

Question 27 continues on page 22

Question 27 (continued)

- (c) Mike and Leonie installed two water tanks to collect water from their roof, and Leonie collected data over the year on how much water was collected and consumed.

The stacked area chart compares the amount of water collected in the tanks and the amount of this water consumed for purposes such as garden, laundry, toilets and so on.

Domestic Water Collection and Consumption

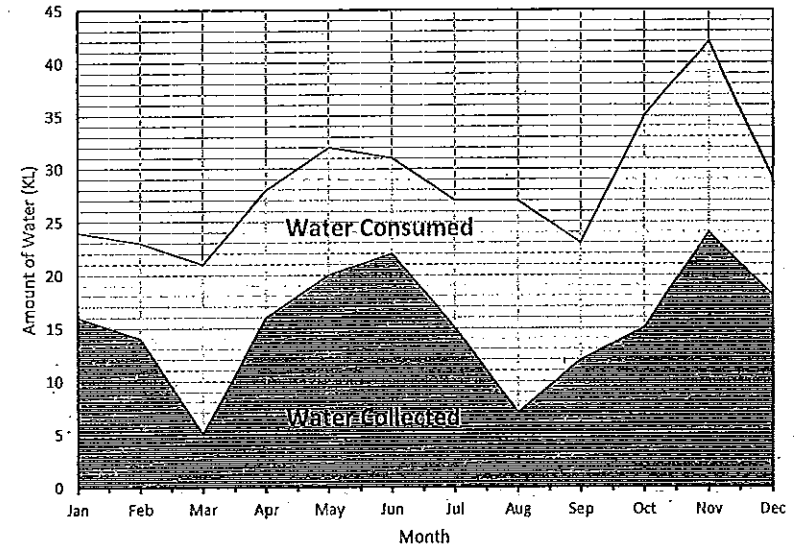

- (i) What was the greatest amount of water consumed in any one month?

.....

- (ii) The net increase or decrease in the water supply in a given month is the amount of water collected minus the amount consumed. What was the greatest net increase in water supply in any one month?

.....

Question 27 continues on page 23

Question 27 (continued)

- (d) Zane bought a car in July 2015 and wants to work out how long to keep the car. He asks for estimates of the resale value from three used car dealers. The results are summarised in the table below.

Dealer	Year							
	2015	2016	2017	2018	2019	2020	2021	2022
Davidson Auto	\$65,000	\$54,600	\$45,864	\$38,526	\$32,362	\$27,184	\$22,834	\$19,181
Gregson Motors	\$65,000	\$54,600	\$44,772	\$35,818	\$27,938	\$22,350	\$17,433	\$14,295
A1 Used Cars	\$65,000	\$57,000	\$49,000	\$41,000	\$33,000	\$25,000	\$17,000	\$9,000

- (i) Zane is deciding between keeping the car for either three years or six years. Outline how the result of this decision would influence his choice of dealer?

1

.....

.....

.....

- (ii) A1 Used Cars uses the straight line depreciation method. Explain how this method works and show how the straight line formula could be used to give the value of \$41 000 which appears in the table.

2

.....

.....

.....

- (iii) A fourth dealer, Smiths Caryard, uses the declining balance method of depreciation with a depreciation rate of 14% pa. What is the value of a car according to Smiths after 5 years?

1

.....

.....

.....

Question 27 (d) continues on page 24

Question 27 (d) (continued)

- (iv) The value of the car according to A1 Used Cars has been drawn on the graph below. On the same set of axes, draw a graph to show the value of the car according to Davidson's Autos for this period of time.

2

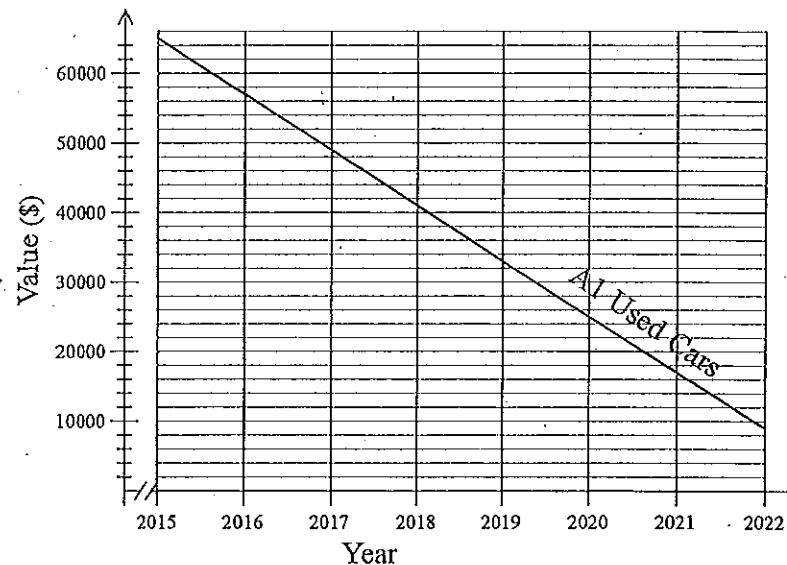

- (v) The value of the car according to Davidsons Autos and A1 Used Cars begins at the same value (\$65 000) in 2015. Is the value according to both dealers ever equal again, and if so what is this value?

1

.....

.....

.....

Question 27 continues on page 25

Question 27 (continued)

- (e) The table below shows the average life expectancy of Australian Females at different ages in 2015.

2

Average Life Expectancies for Females.			
Number of years to live from current age			
Current Age	Number of Years to live	Current Age	Number of Years to live
0	83.67	50	35.17
1	83.04	60	26.00
5	79.11	70	17.42
10	74.14	80	10.01
20	64.25	90	4.91
30	54.44	100	2.74
40	44.70	105	2.32

Consider the statement below.

*When you are born you are expected to live to 83 or 84.
 If you are ninety you are expected to live another 4 to 5 years, so to about 94 or 95.
 If you have already passed your life expectancy, how can you still have 4 or 5 more years to live?*

Explain how you can have an expectancy of 4.91 more years to live when you are ninety.

.....

End of Question 27

Question 28 (15 marks)

- (a) Janessa runs two fitness classes on Fridays at the Urban Active Gym. She records the performance of the members of each class on one of the activities, giving each member a score out of 50. The results are shown on the back to back stem and leaf plot below.

Morning Class		Afternoon Class	
9	0	2	
9 8 4 2	1	8 9	
9 8 5 4 3 3 2	2	2 5 6 6 7 9	
9 6 4 0	3	3 5 6 7 8	
2	4	2 3 9	

- (i) Compare the shape of the two distributions in terms of symmetry and skewness.

1

.....

- (ii) Find the interquartile range for the afternoon class.

1

.....

- (iii) Show that the score of 2 in the afternoon class is an outlier. (Justify your answer with mathematical calculations.)

1

.....

Question 28 continues on page 27

Question 28 (continued)

- (b) Declan's laptop has an internet connection with a download speed of 256 kilobits per second. How many minutes would it take him to download 45 photographs with an average size of 1.6 megabytes? (Answer to the nearest minute)

.....
.....
.....
.....

- (c) Althea and Kyla are twins and are given \$2 000 each by their grandparents for their 18th birthdays. On the day after their birthday, they both invest their money.

- (i) Althea uses her \$ 2 000 to buy a piece of antique jewellery which is predicted to appreciate at 6% pa.
What is the expected value of the jewellery after 6 years?

.....
.....

- (ii) Kyla invests her \$2 000 in shares which cost \$8.00 each and are predicted to pay a dividend of 60 cents per share, once each year. The dividends are paid into a transaction account which pays no interest.

Whose investment will be worth more after 6 years, and by how much?

.....
.....
.....

Question 28 continues on page 28

Question 28 (continued)

- (d) Maxine is designing a new dwelling and, to obtain a BASIX certificate, she must reduce the mains water usage for the dwelling by 120 kilolitres per year. She plans to do this in part by collecting and utilizing rainwater using the tank shown.

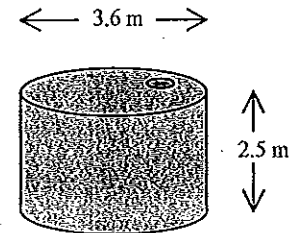

If the tank is filled completely by rain twice during the year, what percentage of her required saving will the tank achieve?

.....
.....
.....

Question 28 continues on page 29

Question 28 (continued)

- (e) Zeva wants to measure the vertical depth of the gully from M to K. She joins stringlines from L to K and J to K so that $\angle LKJ = 90^\circ$, and measures their lengths.

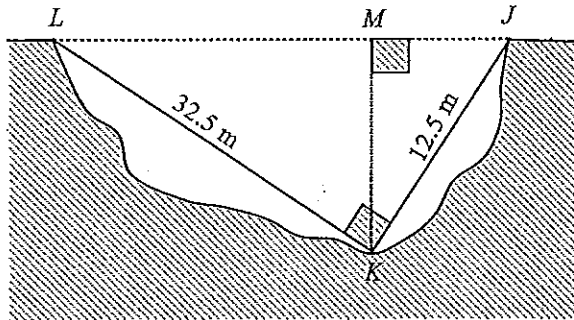

- (i) Calculate the size of $\angle JLK$ (to the nearest degree).

1

.....

.....

.....

- (ii) Calculate the depth of the gully from M to K, correct to the nearest 10^{th} of a metre.

1

.....

.....

.....

Question 28 continues on page 30

Question 28 (continued)

- (f) In a board game there are 50 cards in a pile which are picked up two at a time by the players. Of these cards, 20 have a good outcome for the player, 16 have a bad outcome and the remainder have neutral outcomes.

1

- (i) Complete the three missing probabilities on the tree diagram below for the first player's draw from the deck.

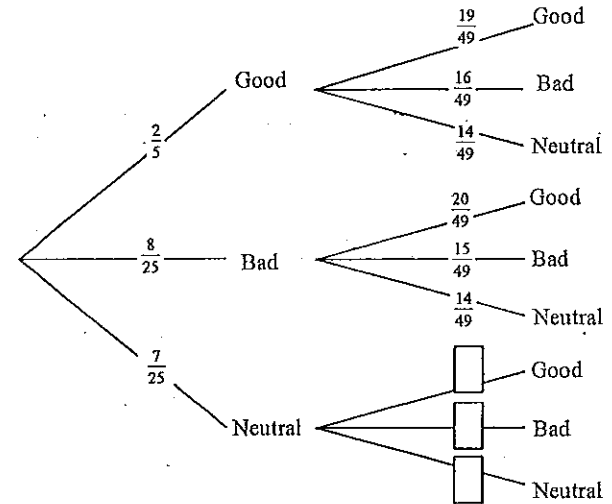

- (ii) What is the probability that the first two cards drawn are not both good outcomes?

1

.....

.....

- (iii) What is the probability that at least one of the first two cards drawn has a good outcome?

1

.....

.....

.....

End of Question 28

Question 29 (15 marks)

(a) Sally and Heather competed in a trivia competition and a dance competition. The scores on both competitions were normally distributed. The mean score in the trivia competition was 70 points with a standard deviation of 12.5, and in the dance competition the mean was 6.2 with a standard deviation of 1.2

(i) Sally scored 95 on the trivia competition. What is this as a z -score? 1

.....

(ii) Heather scored 86 on the trivia competition and 8.6 on the dance competition. In which competition did she do better, compared to the other contestants? 1

.....

(iii) Sally had a z -score of -1.5 on the dance competition. What was her actual score? 1

.....

Question 29 continues on page 32

Question 29 (continued)

(b) An extract from a credit card statement is shown below. 2

Australian Commercial Bank			
Name : Nicholas Shoard		Account number 145 784 683	
Interest rate = 18% p.a.		Daily rate = 0.049%	
Date	Credit	Debit	Balance
01/03/15	Opening balance.		\$842.00
12/03/15		\$362 purchase	\$1 204.00
20/03/15		\$199 purchase	\$1 403.00
25/03/15	\$760 payment		\$643.00
31/03/15	Closing balance		\$643.00

If interest is calculated daily on the maximum daily balance and charged at the end of the month, calculate the interest that will be due for the month of March.

.....

(c) Skeeter lives in Broken Hill (32°S, 141°E). She talks on Skype to two friends; Yumiko who lives in Sendai, Japan (38°N, 141°E) and Tatiana who lives in Calama, Chile (22°S, 69°W).

(i) What is the shortest distance between Broken Hill and Sendai? 1

.....

(ii) Tatiana calls Skeeter at 6pm on Friday, local time in Calama. What is the local time in Broken Hill when Skeeter receives the call? 2

.....

Question 29 continues on page 33

Question 29 (continued)

- (d) The Home Furniture Company makes an occasional chair that they sell to stores. The line on the set of axes below shows the cost of manufacturing up to 12 chairs on a given day. The graph is drawn as a continuous line, for convenience.

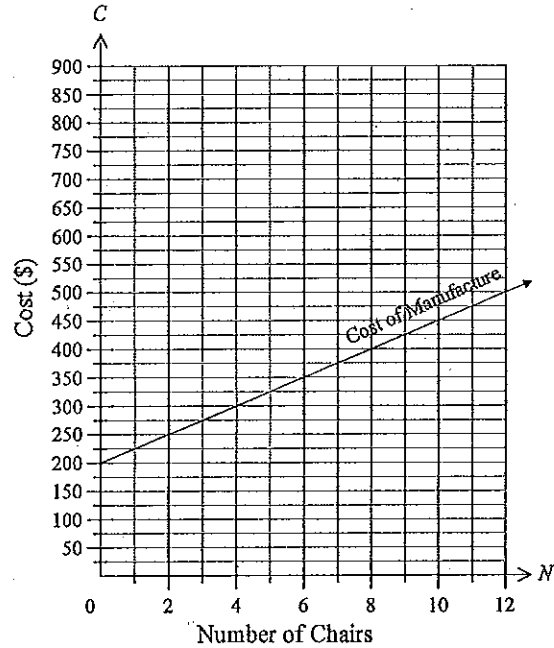

- (i) What is the equation of the line representing the cost of manufacture? 2

.....

.....

.....

- (ii) The chairs are sold for \$75 each. Write this as a linear equation and draw the graph of the equation on the axes above. 2

.....

.....

Question 29 (d) continues on page 34

Question 29 (continued)

- (iii) How many chairs need to be sold to break even? 1

.....

.....

.....

- (e) Solve the following equation: $\frac{5}{a} - 8 = 10 + \frac{9}{2a}$ 2

.....

.....

.....

.....

End of Question 29

Question 30 (15 marks)

(a) Mr and Mrs Jones take out a loan for \$150 000 at an interest rate of 6% pa compounding monthly.

(i) Use the table of present value interest factors to find the amount of the monthly repayment on the loan if it to be repaid in 4½ years.

Present Value Interest Factors

	0.004	0.0045	0.005	0.0055	0.006	0.0065	0.007	0.0075
48	43.59425	43.08315	42.58032	42.08559	41.59882	41.11986	40.64856	40.18478
49	44.41658	43.88567	43.36350	42.84992	42.34475	41.84785	41.35905	40.87820
50	45.23564	44.68459	44.14279	43.61006	43.08623	42.57113	42.06459	41.56645
51	46.05143	45.47993	44.91820	44.36605	43.82329	43.28975	42.76524	42.24958
52	46.86398	46.27170	45.68975	45.11790	44.55596	44.00373	43.46101	42.92762
53	47.67329	47.05993	46.45746	45.86564	45.28425	44.71309	44.15195	43.60061
54	48.47937	47.84463	47.22135	46.60929	46.00820	45.41787	44.83808	44.26860
55	49.28224	48.62582	47.98145	47.34887	46.72784	46.11811	45.51944	44.93161
56	50.08191	49.40350	48.73776	48.08440	47.44318	46.81382	46.19607	45.58969
57	50.87840	50.17770	49.49031	48.81592	48.15425	47.50503	46.86799	46.24287
58	51.67171	50.94843	50.23911	49.54343	48.86109	48.19179	47.53525	46.89118
59	52.46186	51.71571	50.98419	50.26696	49.56370	48.87411	48.19786	47.53467
60	53.24887	52.47956	51.72556	50.98653	50.26213	49.55202	48.85587	48.17337
61	54.03274	53.23998	52.46324	51.70217	50.95639	50.22555	49.50931	48.80732
62	54.81348	53.99699	53.19726	52.41389	51.64651	50.89474	50.15820	49.43654

Number of Periods (N)

(ii) How much additional interest would they pay, over the term of the loan, if they took it over 5 years rather than 4½ years?

Question 30 continues on page 36

Question 30 (continued)

(b) (i) The formula $I = \frac{240}{R}$ gives the amount of current I (in amperes) which flows in 240 volt electrical circuits with varying resistances R (measured in ohms).

What current flows when the resistance is 1.6 ohms?

(ii) What resistance will give a current of 25 amperes?

(iii) The graph of $I = \frac{240}{R}$ has been drawn on the axes below.

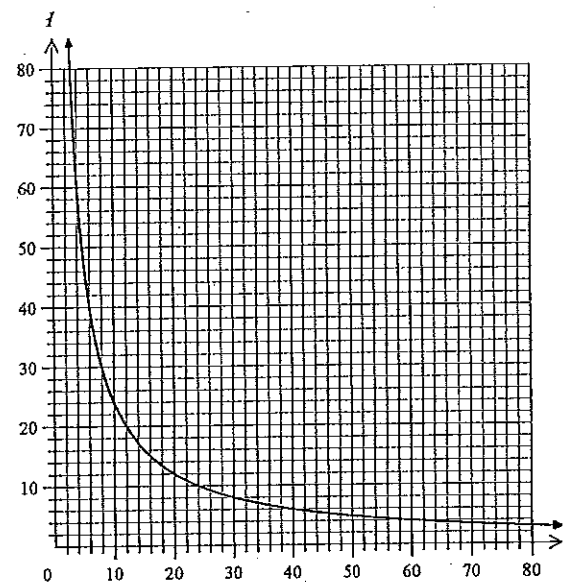

Use the graph to estimate when the resistance R and the current I have the same value on a 240 volt circuit.

Question 30 (b) continues on page 37

Question 30 (b) (continued)

- (iv) For a circuit which operates on a voltage of 1200 volts, the equation is

$$I = \frac{1200}{R}$$

Draw the graph of this equation on the set of axes above.

.....

.....

.....

- (v) For a resistance of 60 ohms, how much difference is there in the current in a 240 volt circuit, compared to a 1200 volt circuit?

.....

.....

.....

Question 30 continues on page 38

Question 30 (continued)

- (c) On her farm, Kelly has two paddocks and a dam as shown in the plan below.

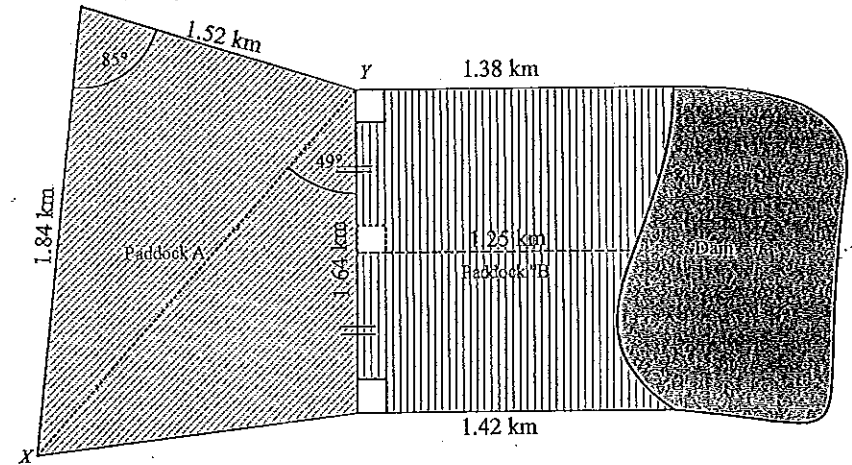

- (i) Show that the distance from X to Y is 2.28 km (correct to 3 significant figures).

.....

.....

.....

- (ii) Calculate the total area of paddock A.

.....

.....

.....

- (iii) Use Simpsons rule to estimate the area of Paddock B.

.....

.....

.....

Question 30 (c) continues on page 39

Question 30 (c) (continued)

- (iv) In one storm there was 25 mm of rain recorded in an hour all across the farm. 2
What amount of water (in megalitres) fell on the two paddocks?
(1 cubic metre holds 1 kilolitre of water)

.....
.....
.....

- (v) The dam holds 480 ML of water when it is full. 1
If 25.5 ML of rain fell directly into the dam and 65% of the rain that fell on the
two paddocks ran off into the dam, what percentage of the dam's capacity did the
storm add to the dam?

.....
.....
.....

End of Paper

Mathematics

General 2

SOLUTIONS

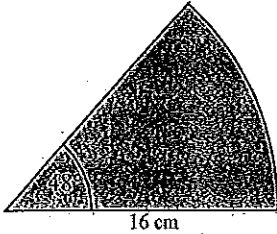
Multiple Choice Worked Solutions		
No	Working	Answer
1	$a = \frac{2(v-ut)}{t^2}$ $v = 30, u = 4 \text{ and } t = 3$ $a = \frac{2(30-4 \times 3)}{3^2}$ $a = \frac{2(18)}{9} = 4$	D
2	<p>Ordered selections of two chosen from 12 can be done in $12 \times 11 = 132$ ways. Unordered selections can be done in $\frac{132}{2} = 66$ ways.</p>	C
3	<p>42 hours is 35 hours at normal rates and 7 hours at time and a half. Earnings = $35 \times 46.5 + 7 \times 46.5 \times 1.5$ $= 1627.5 + 488.25$ $= \\$2\,115.75$</p>	C
4	<p>Find the time used in the calculation</p> $\text{Speed} = \frac{D}{T}$ $50 = \frac{160}{T}$ $T = \frac{160}{50}$ $= 3.2 \text{ hours}$ $= 3 \text{ hours and } 12 \text{ minutes}$ <p>Correct Time = 3 hours and 12 minutes - 42 minutes $= 2 \text{ hours and } 30 \text{ minutes}$</p> <p>Correct Speed = $160 \div 2.5$ $= 64 \text{ km/h}$</p>	D
5	<p>Stamp Duty = 3% of 45 000 + 5% of 12 000. $= \\$1\,350 + \\600 $= \\$1\,950$</p>	C
6	<p>Area = $\frac{48}{360} \times \pi \times 16^2$ $= 107.2 \text{ cm}^2$</p> 	A

7	Amount in each dose = $900 \div 2 = 450$ mg Number of tablets = $450 \div 200 = 2\frac{1}{4}$ tablets	B
8	Bank A Interest = $20000 \times 0.066 \times 3 = 3960$ Value of Investment = \$23 960 Bank B Value of Investment = $20000 \times (1.065)^3 = \$24 158.99$ Bank C Value of Investment = $20000 \times (1.016)^{12} = \$24 196.61$ Bank D Value of Investment = $20000 \times (1.005)^{36} = \$23 933.61$ Bank C gives the best interest.	C
9	Total cost of calls lasting 5 minutes, 3 minutes, 2 minutes and 9 minutes. Total cost = $9.50 + 7.25 + 5.00 + 2.75 = \24.50	D
10	Use the Sine Rule $\frac{\sin F}{12.5} = \frac{\sin 76^\circ}{14.2}$ $(\sin F) = \frac{12.5 \times \sin 76^\circ}{14.2}$ $= 0.8541$ $F = \sin^{-1} 0.8541$ $= 58.664145$ $= 59^\circ$ (nearest degree)	D
11	gradient = $r \times \frac{\text{standard deviation of } y \text{ scores}}{\text{standard deviation of } x \text{ scores}}$ $= -0.8 \times \frac{324}{25}$ $= -10.368$ $= -10.4$ (3 sf)	A

12	Gross annual income = $\$1615.40 \times 52 = \$84\,000.80$ Taxable income = $84000.80 - 3240.00 = \$80\,760.80$ Tax Due = $17547 + 760.8 \times 0.37 = 17547 + 281.496$ $= \$17\,828.496$ $= \$17\,828$	A
13	$S = \frac{D}{T}$ $D = S \times T$ 1 second = $\frac{1}{60 \times 60}$ hours At 100 km/h $D = 100 \times \frac{1}{60 \times 60} \times 1000 \text{ m} = 27.\dot{7}$ At 110 km/h $D = 110 \times \frac{1}{60 \times 60} \times 1000 \text{ m} = 30.\dot{5}$ Additional distance = $30.\dot{5} - 27.\dot{7} = 2.\dot{7} = 2.78$ correct to the nearest cm.	B
14	Area ABE = $\frac{1}{2} \times 80 \times 55$ $= 2200 \text{ m}^2$ Area BCH = $\frac{1}{2} \times 90 \times 15$ $= 675 \text{ m}^2$ Area FDE = $\frac{1}{2} \times 120 \times 10$ $= 600 \text{ m}^2$ Area HCDF = $\frac{30}{2} \times (90 + 120)$ $= 3150 \text{ m}^2$ Total area = 6625 m^2 	A
15	$1516 - 2 \times 145 = 1226$ So 2 SD's below the mean. 95% of scores between $z = \pm 2$ so 5% outside $z = \pm 2$ hence 2.5% below $z = \pm 2$ 2.5% of 2000 = 50	A
16	Line has a gradient of -2 , so equation $y = mx + b$ becomes $y = -2x + b$. When $x = 4$, $y = -8$, so substitute into equation. $8 = -2 \times (-4) + b$ $8 = 8 + b$ $b = 0$ Equation is $y = -2x$	A

17	$\frac{24a^4d^3}{-6d^2e^3} = -\frac{4a^4d}{e^3}$	A
18	From Calculator Mean = 21.6; Standard deviation = 1.8	C
19	Expectation = $\frac{1}{6} \times 0 + \frac{1}{6} \times 2 + \frac{1}{6} \times 6 + \frac{1}{2} \times (-3)$ $= 0 + \frac{1}{3} + 1 - 1\frac{1}{2}$ $= -\frac{1}{6}$ $= -\$0.17$ (nearest cent)	B
20	A4 and B4 are both text cells, so would not affect the calculation of Average Daily and Total Pay. D4 is the hours worked, and since the pay is piecework, this would make no change to the Pays. E4 is the Rate per basket and would be used to calculate the pays, so would affect both values.	D
21	No of songs in 2.5 TB = $\frac{2.5 \times 2^{40}}{3.2 \times 2^{20}}$ $= \frac{2.5 \times 2^{20}}{3.2}$ $= 819\,200$ songs	C
22	<p style="text-align: center;">Outstanding Balance on \$500 000 Loan</p>	D

23	<p>There are about 36 larger squares in the dam.</p> <p>From the scale each square is 2×2 m so area = 4 m^2.</p> <p>Total area = $4 \times 36 = 144 \text{ m}^2$</p> <p>Volume = $144 \times 1.8 = 259.2 \text{ m}^3$</p> <p>Good estimate = 250 m^3</p>		B
24	<p>24 of 54 mice were tagged = $\frac{21}{54} \times 100 = 44.4\%$ of mice in building</p> <p>44.4% of mice = 60 mice</p> <p>1% of mice = $60 \div 44.4 = 1.35$</p> <p>100% of mice = $1.35 \times 100 = 135$ mice</p>	B	
25	<p>Benchmark for the dwelling = $3292 \times 6 = 19752 \text{ kg}$</p> <p>Saving for low rise in zone 2 is $30\% = 0.3 \times 19752 = 5925.6 \text{ kg} = 5.9 \text{ tonnes}$</p>	B	

Question 26		2015	
	Solution	Marks	Allocation of marks
(a)	(i) Number of Ordered Selections = $9 \times 8 \times 7 = 504$	1	1 mark for correct answer
	(ii) Number of ordered pairs = $9 \times 8 = 72$ Number of unordered pairs = $\frac{72}{2} = 36$	1	1 mark for correct answer
(b)	(i) Area of trapezium = $\frac{h}{2}(a + b)$ $= \frac{5}{2}(8 + 12)$ $= 50 \text{ cm}^2$ Area of hexagon = $50 \times 2 = 100 \text{ cm}^2$	1	1 mark for correct answer
	(ii) Volume = Ah $= 100 \times 18$ $= 1800 \text{ cm}^3$ $= 1800 \text{ ml}$ $= 1.8 \text{ litres}$	1	1 mark for correct answer
(c)	(i) Any valid reason could be accepted, for example: Since surveys done at a truck stop, it excludes those who did not stop, or stop by at roadside rest stops. Since only one rest stop used, many drivers will be on the same journey, and all others will be excluded.	1	1 mark for either of these examples or any other valid answer
	(ii) The data is time, so it is quantitative and continuous.	1	1 mark for correct answer which includes both terms.
(d)	$4x(2x - 6y) - 3y(4x - y) = 8x^2 - 24xy - 12xy + 3y^2$ $= 8x^2 - 36xy + 3y^2$	2	2 marks for correct answer 1 mark for working which has either of the expansion or the simplification correct, but an error in the other.
(e)	i) Total data used = $40 \text{ MB} \times 31 \text{ days} = 1240 \text{ MB}$ Included data = $1 \text{ GB} = 1024 \text{ MB}$ Excess data = $1240 - 1024 = 216 \text{ MB}$	1	1 mark for correct answer

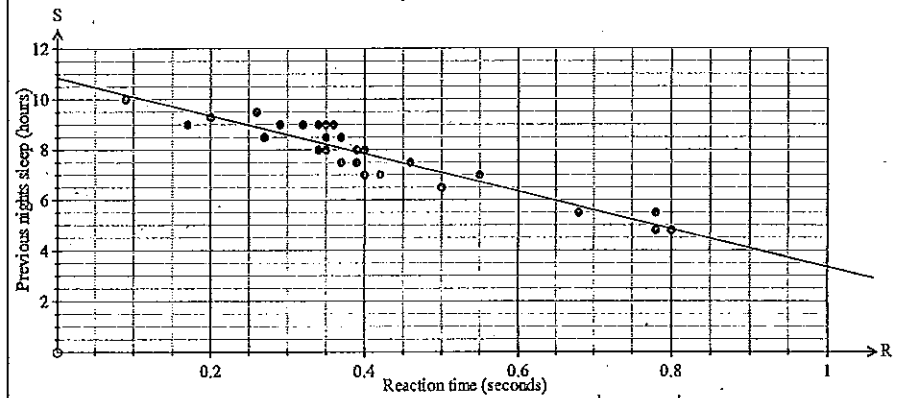
Question 26		2015	
	Solution	Marks	Allocation of marks
	ii) Cost of plan = \$60 Cost of excess data = $216 \times 0.20 = \$43.20$ Total cost of voice calls = $75 \times 0.2 + 150 \times 1.1 = \$15 + \$165$ \$100 allowed for voice calls, so cost of excess = \$80 Total cost of SMS = $120 \times 0.18 = \$21.60$ \$40 allowed for SMS, so no cost for SMS. Total cost for August = $\$60 + \$43.20 + \$80.00 = \183.20	2	2 marks for correct answer 1 mark for working which shows addition of the three amounts, but with excess data or excess voice being incorrect. 1 mark for working where one of the three items is left out in the calculation.
(f)	(i) Use equation to obtain any two points. For example: $R = 0.2$ $S = -7.5 \times 0.2 + 10.8 = 9.3$ Point (0.2, 9.3) $R = 1$ $S = -7.5 \times 1 + 10.8 = 3.3$ e.g. Point (1.0, 3.3)	1	1 mark for correct line using any method
	Scatterplot of Reaction times 		

Question 26		2015	
	Solution	Marks	Allocation of marks
	(ii) When $S = 6$ $6 = -7.5R + 10.8$ $6 - 10.8 = -7.5R$ $-4.8 = -7.5R$ $R = \frac{-4.8}{-7.5}$ $= 0.64$ $= 0.6$ (nearest 10th sec) Or from reading off graph.	1	1 mark for correct answer
(g)	Cash price for car = \$25600 Stamp duty = $0.03 \times 25\,600 = \$768$ CTP insurance = \$356.50 Dealer delivery = $26 \times 15.4 = \$400.40$ Registaration = \$277.00 Total cost to get on road = $25600 + 768 + 356.5 + 400.4 + 277 = \$27\,401.90$	2	2 marks for correct answer. 1 mark if either the stamp duty or Dealer delivery are calculated correctly.

Question 27		2015	
	Solution	Marks	Allocation of marks
(a)	(i) Weekly Savings = Income - expenses $= 1290 - 870 = \$420$ Total required = $6500 + 1200 = \$7\,700$ Number of weeks required = $7700 \div 420 = 18.33 = 19$ weeks	1	1 mark for correct answer
	(ii) Without weekend work, Savings = $990 - 870 = \$120$ To achieve in 52 weeks need = $7700 \div 120 = \$64.17$ per week Needs to take \$28.08 from Other expenses to achieve goal in one year.	1	1 mark for correct answer
(b)	(i) Scale factor = $\frac{12.5}{5.0} = 2.5$ or Scale factor = $\frac{5.0}{12.5} = 0.4$	1	1 mark for correct answer
	(ii) $DE \times 2.5 = 10.0$ or $DE = 10.0 \times 0.4$ $DE = 10.0 \div 2.5$ $DE = 4.0$ km	1	1 mark for correct answer
(c)	(i) In August there was 20 KL consumed. (on the graph 27 - 7 = 20)	1	1 mark for correct answer <i>Only the amount is needed</i>
	(ii) In June the amount collected was 22 KL with 9KL consumed, giving a net increase of 13 KL.	1	1 mark for correct answer <i>Only the amount is needed</i>
(d)	(i) If he keeps the car for 3 years A1 Used cars would give him the best resale price by around \$2 500 but after 6 year it would be the lowest, with Davidson's Auto being the best by around \$5 800.	1	1 mark for answer which indicated that the best deal is different for the two times.
	(ii) The straight line depreciation method operates on the vehicle reducing by the same amount each year. In this case, the annual amount is $65000 - 57000 = \$8\,000$. The formula $S = V_0 - Dn$ would become $S = 65000 - 8000n$ After three years $S = 65000 - 8000 \times 3 = \$41\,000$ as in the table.	2	1 mark for any reasonable explanation 1 mark for using the formula to get \$41 000.
	(iii) Use the formula $S = V_0(1 - r)^n$ $S = 65000(1 - 0.14)^5$ $= 65000(0.86)^5$ $= \$30578$ (to the nearest dollar)	1	1 mark for answer

Question 27		2015	
Solution	Marks	Allocation of marks	
<p>(iv)</p>	2	<p>2 marks for a smooth curve following the points for Davidson Autos.</p> <p>1 mark for a graph with only points plotted.</p> <p>1 mark for a curve with errors in plotting.</p> <p>1 mark if straight lines are used to join the points instead of a curve.</p>	
<p>(v) They both give a value of around \$31 000 late in 2019.</p>	1	<p>1 mark for a value between \$30 000 and \$32 000. (or for a correctly found answer from their incorrect graph in (iv)?)</p>	
<p>(e) Life expectancies need to be viewed as probabilities, based on data obtained from past records. The table gives the expectations based on the probabilities of related events.</p> <p>On being born, (not a certain event in itself) the data says that you are likely to live for another 83.67 years. If you reach ninety you have already beaten the odds and lived longer than most other people, but you still have a likelihood of living longer, (based on data for ninety year olds) and the expectation is that it will be 4.91 years.</p>	2	<p>2 marks for an answer which mentions probabilities (likelihoods) based on data and some mention that the expectancy at ninety is conditional on having reached that age.</p> <p>1 mark for any incomplete explanation that includes some of the relevant information.</p>	

Question 28		2015													
Solution	Marks	Allocation of marks													
<p>(a) (i) The morning class is symmetrical while the afternoon class is negatively skewed.</p>	1	1 mark for using the correct terms for each distribution.													
<p>(ii)</p> <table border="1" style="margin-left: 20px;"> <thead> <tr> <th colspan="2">Afternoon Class</th> </tr> </thead> <tbody> <tr> <td>0</td> <td>2</td> </tr> <tr> <td>1</td> <td>8 9</td> </tr> <tr> <td>2</td> <td>2 3 5 5 6 6 7 9</td> </tr> <tr> <td>3</td> <td>3 5 6 7 7 5 8</td> </tr> <tr> <td>4</td> <td>2 3 9</td> </tr> </tbody> </table> <p>Median $Q_M = 29$ $Q_L = 23.5$ $Q_U = 37.5$ $IQR = 37.5 - 23.5 = 14$</p>	Afternoon Class		0	2	1	8 9	2	2 3 5 5 6 6 7 9	3	3 5 6 7 7 5 8	4	2 3 9	1	1 mark for the correct answer	
Afternoon Class															
0	2														
1	8 9														
2	2 3 5 5 6 6 7 9														
3	3 5 6 7 7 5 8														
4	2 3 9														
<p>(iii) Outliers if less than $Q_L - 1.5 \times IQR = 23.5 - 1.5 \times 14 = 23.5 - 21 = 2.5$</p> <p>So 2 is an outlier as it is less than 2.5.</p>	1	1 for correct answer.													
<p>(b) Total amount to download = $45 \times 1.6 \text{ MB} = 72 \text{ MB} = 72 \times 2^{20} \text{ bytes} = 72 \times 2^{20} \times 8 \text{ bits} = 603\,979\,776 \text{ bits}$</p> <p>Download speed = $603\,979\,776 \div 256\,000 \text{ seconds} = 2359.296 \text{ seconds} = 39.3216 \text{ minutes} = 39 \text{ minutes (nearest minute)}$</p>	2	2 marks for correct answer, regardless of rounding. 1 mark for an incorrect answer which includes some of the correct working for the conversions required.													
<p>(c) (i) Value after 6 years = $2000(1.06)^6 = \\$2\,837.04$</p>	1	1 mark for correct answer													
<p>(ii) Number of shares = $2000 + 8 = 250$ Dividend = $250 \times 0.6 \times 6 = \\900 Value of investment = $\\$2\,900$ Kyla's investment is more by $\\$62.96$</p>	2	2 marks for correct answer. 1 mark for an answer which calculates the dividend correctly with other errors. or makes a minor error in an otherwise correct calculation of the answer.													

Question 28		2015	
	Solution	Marks	Allocation of marks
(d)	<p>Volume of tank = $\pi \times 1.8^2 \times 2.5$ $= 25.446 \text{ m}^3$ $= 25.446 \text{ kL}$</p> <p>If filled twice Water saved = $25.446 \text{ kL} \times 2$ $= 50.893 \text{ kL}$</p> <p>Percentage saved = $\frac{50.893}{120} \times 100$ $= 42.411$ $= 42\%$ (to nearest percent)</p>	2	<p>2 marks for correct answer, regardless of rounding.</p> <p>1 mark for an incorrect answer which includes either the correct volume or correct working for the percentage of the saving.</p>
(e)	<p>(i) In Δ JLK $\tan \angle JLK = \frac{12.5}{32.5}$ $\angle JLK = \tan^{-1}\left(\frac{12.5}{32.5}\right)$ $\angle JLK = 21.03751$ $= 21^\circ$ (nearest degree)</p>	1	1 mark for correct answer
	<p>(ii) In Δ LMK $\angle MLK = \angle JLK$ (same angle) $\sin \angle MLK = \frac{MK}{LK}$ $\sin 21^\circ = \frac{MK}{32.5}$ $MK = 32.5 \times \sin 21^\circ$ $= 11.666820077538244291242307092183$ $= 11.7 \text{ m}$ (nearest tenth of a metre) Also accept 11.6 m</p>	1	1 mark for correct answer
(f)	<p>(i)</p> <pre> graph LR Root(()) --- B1[2/5] -- Good Root --- B2[8/25] -- Bad Root --- B3[7/25] -- Neutral B1 --- B1G[19/49] -- Good B1 --- B1B[16/49] -- Bad B1 --- B1N[14/49] -- Neutral B2 --- B2G[20/49] -- Good B2 --- B2B[15/49] -- Bad B2 --- B2N[14/49] -- Neutral B3 --- B3G[20/49] -- Good B3 --- B3B[16/49] -- Bad B3 --- B3N[13/49] -- Neutral </pre>	1	1 mark if all three given correctly

Question 28		2015	
	Solution	Marks	Allocation of marks
	<p>(ii) $P(\text{Not both good}) = 1 - P(\text{Both good})$ $= 1 - \frac{2}{5} \times \frac{19}{49}$ $= 1 - \frac{38}{245}$ $= \frac{207}{245}$</p>	1	1 for correct answer
	<p>(iii) $P(\text{at least 1 good}) = \frac{2}{5} + \frac{8}{25} \times \frac{20}{49} + \frac{7}{25} \times \frac{20}{49}$ $= \frac{98}{245} + \frac{32}{245} + \frac{28}{245}$ $= \frac{158}{245}$</p>	1	1 for correct answer

Question 29		2015	
	Solution	Marks	Allocation of marks
(a)	(i) $z = \frac{x - \bar{x}}{s}$ $= \frac{95 - 70}{12.5}$ $= \frac{25}{12.5}$ $= 2$	1	1 mark for correct answer
	(ii) Trivia $z = \frac{86 - 70}{12.5}$ $= \frac{16}{12.5}$ $= 1.28$ Dance $z = \frac{8.6 - 6.2}{1.2}$ $= \frac{1.2}{1.2}$ $= 2.0$ The dance score has a higher z score, so is better in comparison.	1	1 mark for correct answer
	(iii) $z = \frac{x - \bar{x}}{s}$ $-1.5 = \frac{x - 6.2}{1.2}$ $x - 6.2 = -1.5 \times 1.2$ $x - 6.2 = -1.8$ $x = -1.8 + 6.2$ $= 4.4$ Her actual dance score was 4.4	1	1 mark for correct answer
(b)	Interest from 1st to 11th = $842 \times 0.00049 \times 11 = 4.53838$ Interest from 12th to 19th = $1204 \times 0.00049 \times 8 = 4.71968$ Interest from 20th to 25th = $1403 \times 0.00049 \times 6 = 4.12482$ Interest from 26th to 31st = $643 \times 0.00049 \times 6 = 1.89042$ Total Interest = $\$15.2733$ $= \$15.27$	2	2 marks for correct answer 1 mark for working which has a minor error in calculation or in method.
(c)	(i) Angle = $32^\circ + 38^\circ = 70^\circ$ Distance $l = \frac{\theta}{360} \times 2\pi r$ $= \frac{70}{360} \times 2 \times \pi \times 6400$ $= 7819 \text{ km}$	1	1 mark for correct answer

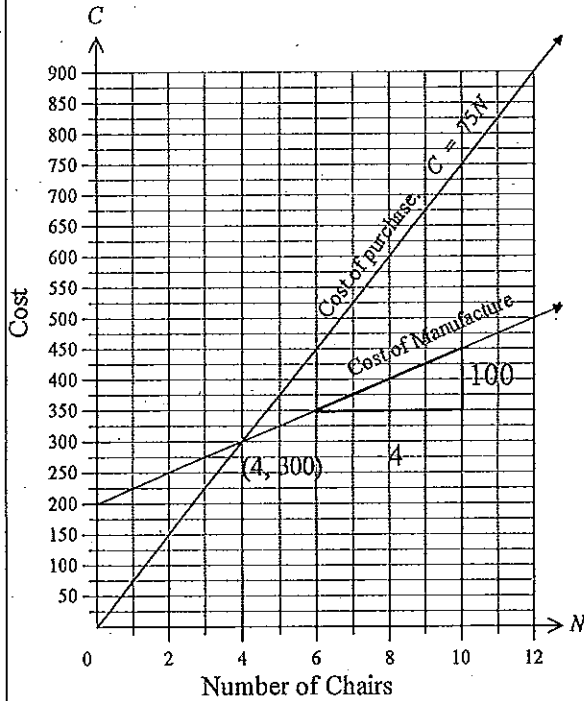
Question 29		2015	
	Solution	Marks	Allocation of marks
	(ii) Longitude difference = $141^\circ + 69^\circ = 210^\circ$ Time difference = $210^\circ \div 15 = 14 \text{ hours}$ Broken hill is 14 hours ahead of Calama. 6 pm + 14 hours = $1800 + 1400$ $= 3200$ (- 2400 as over 24 hrs) $= 0800$ on the next day $= 8 \text{ am}$ on Saturday.	2	2 marks for correct answer 1 mark for working which includes correct time difference or has a minor error in calculation or in method.
(d)	(i)  Gradient = $\frac{100}{4} = 25$ y (C) intercept = 200 Equation $C = 25N + 200$	2	2 marks for correct equation 1 mark for an equation which is of the correct form, but has one of the gradient or intercept incorrect.
	(ii) The equation of the line is $C = 75N$ and its' graph is shown on the axes above.	2	1 mark for correct equation 1 mark for correct graph of equation given by student.
	(iii) The break-even point is (4, 300) which means you need to make 4 chairs to break even.	1	1 mark for correct answer from students' graph.

Question 29		2015	
	Solution	Marks	Allocation of marks
(e)	$\frac{5}{a} - 8 = 10 + \frac{9}{2a}$ $2a \times \frac{5}{a} - 2a \times 8 = 2a \times 10 + 2a \times \frac{9}{2a}$ $10 - 16a = 20a + 9$ $1 - 16a = 20a$ $1 = 36a$ $a = \frac{1}{36}$	2	<p>2 marks for correct solution.</p> <p>1 mark for working which shows the correct elimination of the fractions, or which has a minor numerical or algebraic error.</p>

Question 30		2015	
	Solution	Marks	Allocation of marks
(a)	<p>(i) $6\% \text{ pa} = 6 \div 12 = 0.5\% \text{ per month } (r = 0.005)$</p> <p>$4\frac{1}{2} \text{ years} = 4\frac{1}{2} \times 12 = 54 \text{ months } (N = 54)$</p> <p>Interest factor = 47.22135</p> <p>Amount of loan = Repayment \times factor</p> <p>$150\,000 = \text{Repayment} \times 47.22135$</p> <p>Repayment = $\frac{150\,000}{47.22135} = \\$3\,176.53$</p>	1	1 mark for answer
	<p>(ii) Over 54 months total amount paid = $54 \times 3176.53 = \\$171\,532.62$</p> <p>Interest paid = $171\,532.62 - 150\,000 = 21\,532.62$</p> <p>Over 5 years (60 months) factor = 51.72556</p> <p>Repayment = $\frac{150\,000}{51.72556} = \\2899.92</p> <p>Over 60 months total amount paid = $60 \times 2899.92 = \\$173\,995.20$</p> <p>Interest paid = $173\,995.20 - 150\,000 = 23\,995.20$</p> <p>Extra interest = $23995.20 - 21532.62 = \\$2\,462.58$</p>	2	<p>2 marks for correct answer.</p> <p>1 mark for working which shows some progress toward the correct answer, such as calculation of the total interest for at least one of the time periods.</p>
(b)	<p>(i) $I = \frac{240}{R}$</p> <p>$I = \frac{240}{1.6}$</p> <p>$= 150 \text{ amperes}$</p>	1	1 mark for correct answer.
	<p>(ii) $I = \frac{240}{R}$</p> <p>$25 = \frac{240}{R}$</p> <p>$R \times 25 = 240$</p> <p>$R = \frac{240}{25}$</p> <p>$R = 9.6 \text{ ohms}$</p>	1	1 mark for correct answer.

Question 30		2015	
Solution	Marks	Allocation of marks	
(iii) <p>The dotted line shows where R and I are equal. The line meets the graph at around (15.5, 15.5) The resistance and current have the same value at 15.5.</p>	1	1 mark for correct answer. Accept answers between 15 and 16	
(iv) See Graph above of $I = \frac{1200}{R}$	1	1 mark for correct answer.	
(v) For 1200 volt current is 20 and for 240 volt current is 4, so difference is $20 - 4 = 16$ amperes.	1	1 mark for correct answer.	

Question 30		2015	
Solution	Marks	Allocation of marks	
(c)			
(i) Using the cosine rule $XY^2 = 1.84^2 + 1.52^2 - 2 \times 1.84 \times 1.52 \times \cos 85^\circ$ $= 5.696 - 0.487514$ $= 5.20848$ $XY = \sqrt{5.20848}$ $= 2.28221$ $= 2.28 \text{ km (3 sf)}$	1	1 mark for correct answer	
(ii) Area 1 = $\frac{1}{2} \times 1.84 \times 1.52 \times \sin 85^\circ$ $= 1.393$ Area 2 = $\frac{1}{2} \times 2.28 \times 1.64 \times \sin 49^\circ$ $= 1.411$ Area Paddock A = $1.393 + 1.411$ $= 2.804$ $= 2.8 \text{ km}^2 \text{ (2 s.f.)}$	2	2 marks for correct answer (any rounding acceptable) 1 mark for calculating either of the triangles correctly.	
(iii) Area = $\frac{0.82}{3} (1.42 + 4 \times 1.25 + 1.38)$ $= \frac{0.82}{3} (7.8)$ $= 2.132$ $= 2.13 \text{ km}^2 \text{ (3 s.f.)}$	1	1 mark for correct answer	

	Solution	Marks	Allocation of marks
	(iv) Total area of the two paddocks = $2.13 + 2.81$ = 4.94 km^2 $1 \text{ km}^2 = 1000 \text{ m} \times 1000 \text{ m}$ = $1\,000\,000 \text{ m}^2$ Total area of the two paddocks = $4.94 \times 1\,000\,000$ = $4\,940\,000 \text{ m}^2$ Depth of rain = $25 \text{ mm} = 0.025 \text{ m}$ Volume of rain = $4\,940\,000 \times 0.025$ = $123\,500 \text{ m}^3$ = $123\,500 \text{ kL}$ = 123.5 ML	2	2 marks for correct answer (or correct working obtained from a previous incorrect answer) 1 mark for an incorrect answer which has a single error in calculation or in reasoning, or conversion of quantities.
	(v) 65% of 123.5 ML = 80.275 ML Amount added = $80.275 + 25.5$ = 105.775 ML Percentage added = $\frac{105.775}{480} \times 100$ = 22.036 = 22% (nearest percent)	1	1 mark for correct answer or correct working obtained from a previous incorrect answer)