

# Revision & Practice

## A Cartesian plane: Plotting cubic equations

Generate a set of points for these cubics and plot them on a set of axes:

1  $y = \frac{1}{2}x^3 - 4$

x	-2	-1	0	1	2
y					

2  $y = 1 + x - x^3$

x	-2	-1	0	1	2
y					

3  $y = 2x^3 - 5x$

x	-2	-1	0	1	2
y					

## B Geometry: Properties of circles

Find the missing sides or angles:

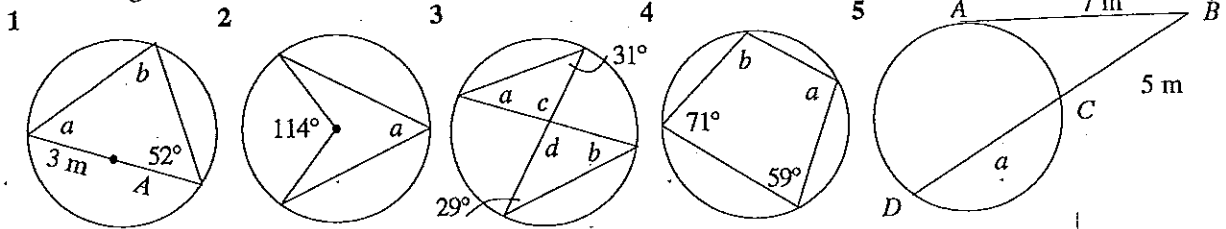

## C Geometry: Symmetrical properties of plane shapes

- List the first ten letters of the alphabet and show any axes of symmetry
- Identify the angle through which these shapes need to be rotated to show that they have rotational symmetry. Which of these have point symmetry?



## D Measurement: Surface area of solids

Find the total surface area of these solids:

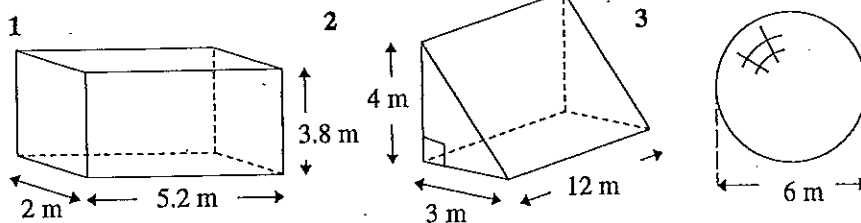

## E Trigonometry: Using cos to find side lengths

Find the missing lengths:

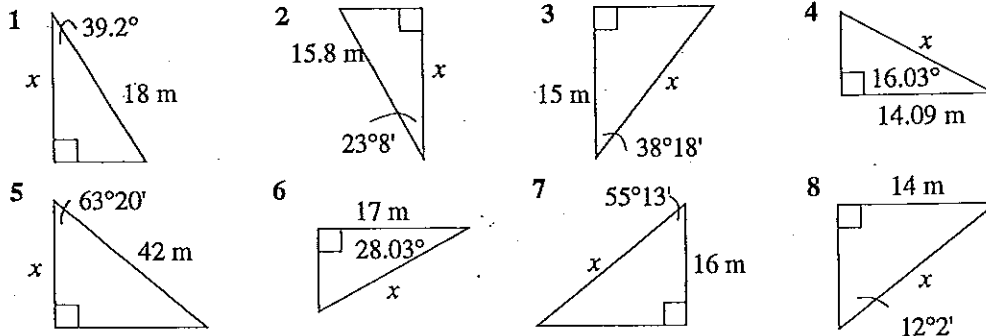

A 1  $(-8, -4\frac{1}{2}, -4, -3\frac{1}{2}, 0)$  2  $(7, 1, 1, 1, -5)$

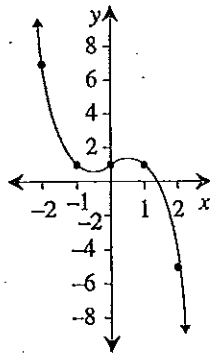
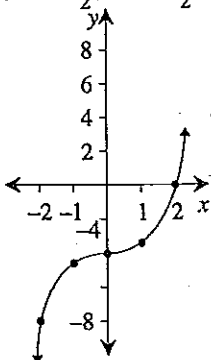

3  $(-6, 3, 0, -3, 6)$

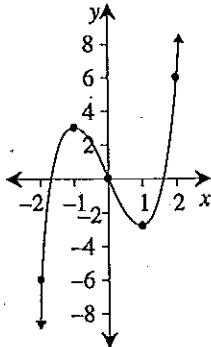

B 1  $a = 38^\circ$  2  $a = 57^\circ$

$b = 90^\circ$   
 $A = 3 \text{ m}$

3  $a = 29^\circ$  4  $a = 109^\circ$   
 $b = 31^\circ$   $b = 121^\circ$

$c = d = 120^\circ$

5  $A = 9.8 \text{ m}$

C 1 **ABCDEFGHIJ**

**A<sup>1</sup>B<sup>1</sup>C<sup>1</sup>D<sup>1</sup>E<sup>1</sup>H<sup>1</sup>I<sup>1</sup>I<sup>2</sup>I<sup>2</sup>**

2 (a)  $180^\circ$  point symmetry (b)  $51\frac{3}{7}^\circ$

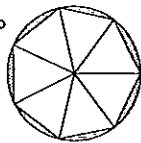

(c)  $180^\circ$  point symmetry

D 1  $75.52 \text{ m}^2$  2  $96 \text{ m}^2$  3  $113.10 \text{ m}^2$

E 1  $13.95 \text{ m}$  2  $14.53 \text{ m}$  3  $19.11 \text{ m}$

4  $14.66 \text{ m}$  5  $18.85 \text{ m}$  6  $19.26 \text{ m}$

7  $28.05 \text{ m}$  8  $14.31 \text{ m}$