

Perimeter and area

Question 1 Find the perimeter of each of the following figures:

(a)

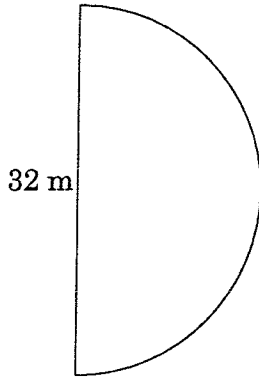

$P =$ _____

(b)

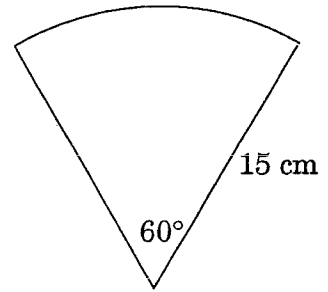

$P =$ _____

(c)

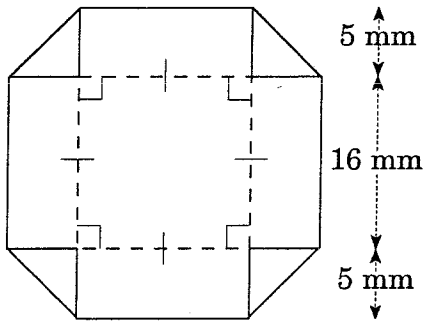

$P =$ _____

(d)

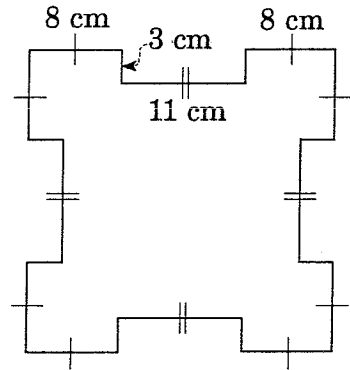

$P =$ _____

Question 2

(a) An athlete runs along the inside track of the field.
 How far does he run if he does three laps?

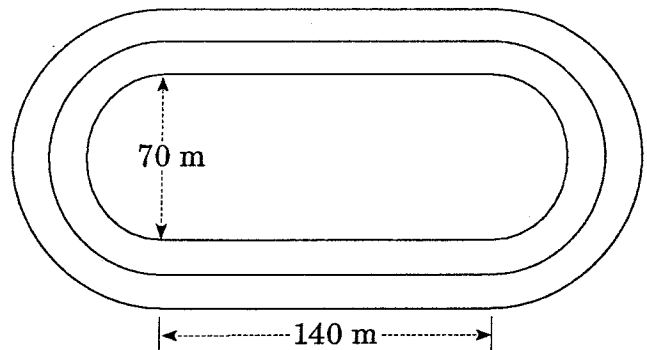

(b) A second athlete runs in the next lane, 1 m further out. How far ahead must the second athlete start in order to run the same distance as the first athlete if they run only one lap?



Question 3

Calculate the shaded area of each of the following figures:

(a)

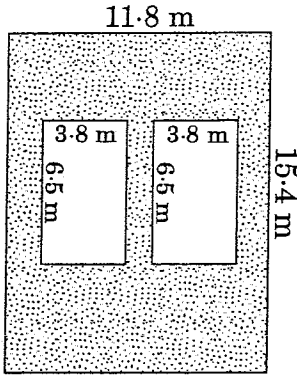

A = _____

(b)

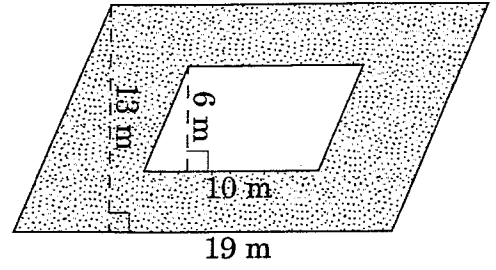

A = _____

(c)

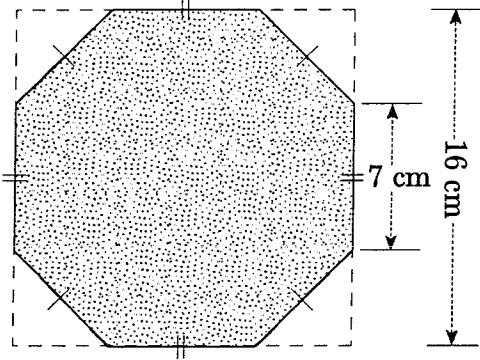

A = _____

(d)

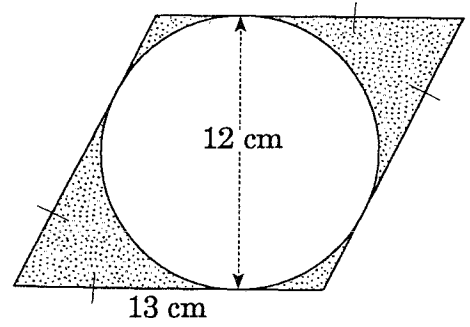

A = _____

(e)

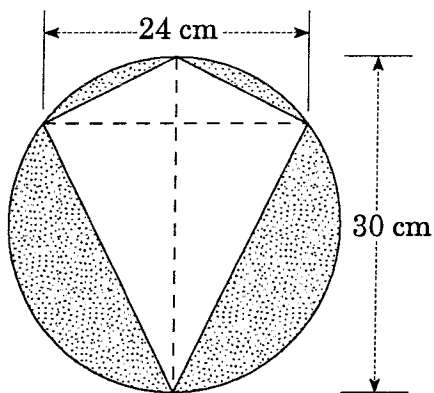

A = _____

(f)

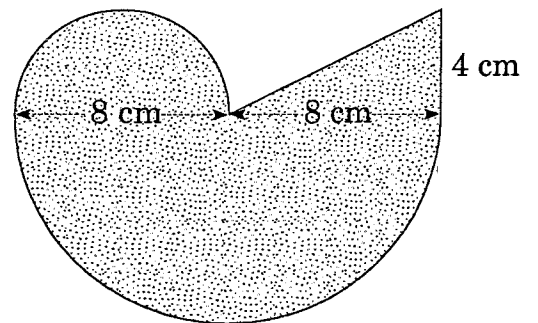

A = _____

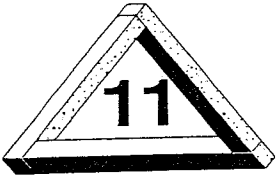

Volume and surface area

Question 1 Calculate the volume and the surface area of each of the following solids:

(a)

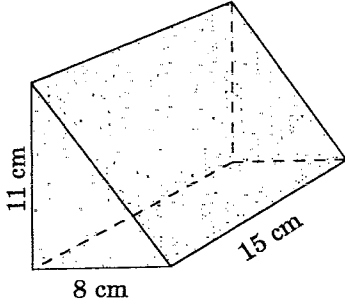

V = _____
 SA = _____

(c)

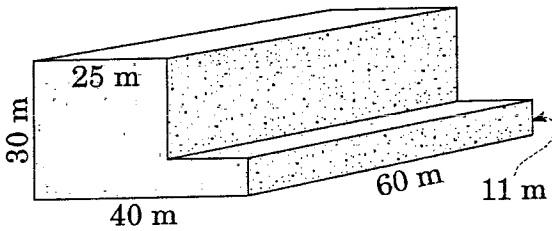

V = _____
 SA = _____

(e)

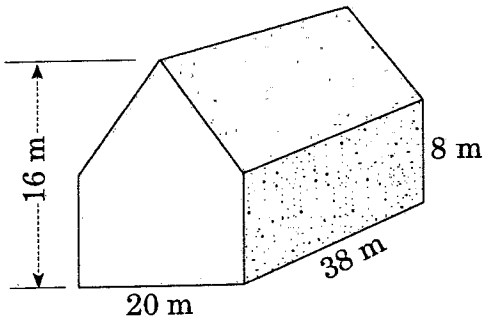

V = _____
 SA = _____

(b)

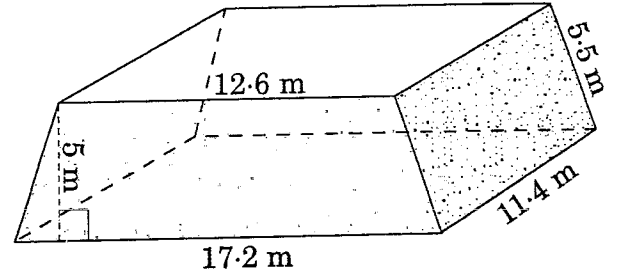

V = _____
 SA = _____

(d)

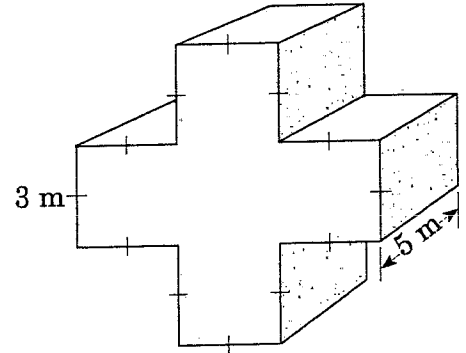

V = _____
 SA = _____

(f)

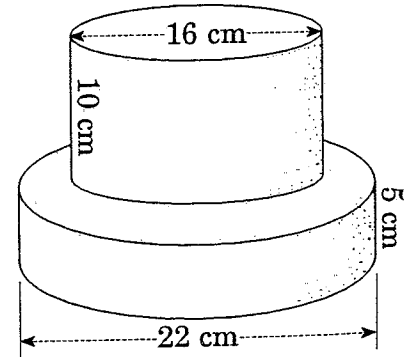

V = _____
 SA = _____

(g)

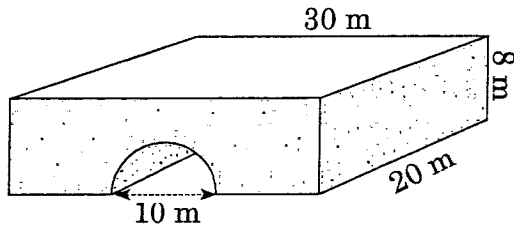

$V =$ _____

$SA =$ _____

(h)

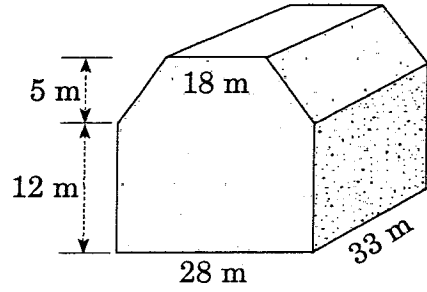

$V =$ _____

$SA =$ _____

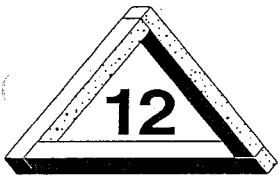

Solving problems with equations

By first setting up an equation, solve each of the following problems:

1 The sum of three consecutive integers is 471. Find the middle one.

4 The length of a rectangle is 5 more than twice the width. Find its dimensions if the perimeter is 64 cm.

2 In a class of 36 students there are 12 more girls than boys. How many girls are there?

5 In a yacht race the second leg is twice as long as the first, while the third leg is 10 km longer than the second.

Find the length of the second leg if the race is run over a distance of 15 km.

3 A triangle has a perimeter of 47 cm. If one side is 9 cm longer than the second side, and the third side is 4 cm shorter than the second side, find the length of the second side.



Area and volume: problems

Sketch a diagram to help solve these problems:

- 1 The cross-section of a steel pipe is an annulus with inner and outer radii of 10.5 cm and 14 cm respectively.

Find the volume of metal in a length of 10 metres of pipe.

- 2 A car's engine has 4 cylinders, each of diameter 7.8 cm and height 8.4 cm.

Find the capacity of the engine in cc.

- 3 A swimming pool has a length of 50 m and width 30 m. At the shallow end the water is 0.9 m deep and at the other end it is 2.3 m deep.

Find the volume in cubic metres and hence the capacity in litres.

- 4 A closed cube has a volume of 216 m^3 . Find the length of each side, and hence the surface area.

- 5 A rectangular prism has its surface area equal to 184 cm^2 . If its length and breadth are respectively 8 cm and 4 cm, find its height.

- 6 A cylinder has a volume of 462 cm^3 . Find:
(a) the height if its radius is 3.5 cm

- (b) the radius if the height is 3 cm.

The curved surface area of a cylinder is 264 cm^2 . Find the height if the radius is 14 cm.

A car's engine has 6 cylinders, with a total capacity of 3000 cc.

(a) If the diameter of each cylinder is 8.2 cm, find the height of each cylinder.

(b) If the height of each cylinder is 12 cm, find the radius of each cylinder.

9 A square sheet of metal of side 12 cm has a square piece cut out from each corner. The remaining piece is folded to form a cube with an open top.

(a) Find the area cut off.

(b) Find the volume of the cube.

10 A rectangular prism 4 m long by 3 m wide by 1 m high is half filled with water. The water is drained into a cylindrical tank of diameter 2.4 m. To what height will the water rise in the tank?



Indices

Question 1 Simplify the following:

(a) $n^4 \times n =$

(b) $y^3 \times y \times y^6 =$

(c) $n^6 \div n =$

(d) $p^3 \times p^7 \div p^4 =$

(e) $\frac{m^6}{m^5} =$

(f) $(a^3)^4 =$

(g) $7n^5 \times 5n^7 =$

(h) $x^4 y^2 \times x^5 y^3 =$

(i) $4x^{10} y^6 \div 2x^5 y^3 =$

9 Equations

- 1 (a) $m = 7$ (b) $a = -26$ (c) $x = 4$
 (d) $y = -2$ (e) $p = -3\frac{1}{2}$ (f) $b = -13$
- 2 (a) $y = 5\frac{4}{7}$ (b) $x = 1\frac{3}{5}$ (c) $a = -4\frac{3}{4}$
 (d) $y = -\frac{3}{5}$ (e) $m = 9\frac{2}{5}$ (f) $r = -3$
- 3 (a) $a = 3$ (b) $x = -1\frac{1}{5}$ (c) $m = 4\frac{1}{2}$
 (d) $r = -4$ (e) $x = -2\frac{1}{2}$ (f) $y = 2$
- 4 (a) $x = 3\frac{1}{3}$ (b) $p = -2\frac{3}{4}$ (c) $m = 1\frac{5}{8}$
 (d) $x = 3\frac{3}{5}$ (e) $q = 30$ (f) $n = 15\frac{3}{4}$
- 5 (a) $p = 32$ (b) $n = 3$ (c) $d = -5\frac{4}{5}$
 (d) $q = 14\frac{1}{2}$ (e) $x = 11$ or $x = -1$
 (f) $x = 22$
- 6 (a) $S = 90$ (b) $v = 15.52$ (c) $V = 40192$
 (d) $C = 35$ (e) $V = 2662.95$ (f) $S = 1440$
 (g) $x = -1$ or $-\frac{2}{3}$ (h) $R = 15$

10 Perimeter and area

Answers may vary slightly, depending on the value of π used.

- 1 (a) 82.27 m (b) 45.71 cm
 (c) 92.28 mm (d) 132 cm
- 2 (a) 499.91 m (b) 6.28 m
- 3 (a) 132.32 m² (b) 187 m² (c) 215.5 cm²
 (d) 42.9 cm² (e) 346.86 cm² (f) 141.66 cm²

11 Volume and surface area

- 1 (a) $V = 660 \text{ cm}^3$ (b) $V = 849.3 \text{ m}^3$
 $SA = 577.02 \text{ cm}^2$ $SA = 614.12 \text{ m}^2$
- (c) $V = 54900 \text{ m}^3$ (d) $V = 225 \text{ m}^3$
 $SA = 10230 \text{ m}^2$ $SA = 270 \text{ m}^2$
- (e) $V = 9120 \text{ m}^3$ (f) $V = 3911.3 \text{ cm}^3$
 $SA = 2821.27 \text{ m}^2$ $SA = 1608.5 \text{ cm}^2$
- (g) $V = 4014.6 \text{ m}^3$ (h) $V = 14883 \text{ m}^3$
 $SA = 2035.5 \text{ m}^2$ $SA = 2886.69 \text{ m}^2$

12 Solving problems with equations

- 1 157
 2 24 girls
 3 14 cm
 4 9 cm by 23 cm
 5 2 km

13 Area and volume: problems

- 1 269 391.57 cm³
 2 1605.5 cc
 3 2400 m³; 2 400 000 litres
 4 length 6 m; surface area 216 m²
 5 5 cm
 6 (a) 12 cm (b) 7 cm
 7 ~~6 cm~~ 3 cm
 8 (a) 9.5 cm (b) 3.6 cm
 9 (a) 64 cm² (b) 64 cm³
 10 1.3 m

14 Indices

- 1 (a) n^5 (b) y^{10} (c) n^5
 (d) p^6 (e) m (f) a^{12}
 (g) $35n^{12}$ (h) x^9y^5 (i) $2x^5y$
 (j) $1024p^5q^{15}$ (k) $8m^3$ (l) $36x^{12}$
- 2 (a) $121x^{14}y^6z^{24}$ (b) a^2 (c) x^{10}
 (d) m^7 (e) $9m^4p^6$ (f) $2x^4y$
 (g) p^7q^5 (h) $4m^3n^6$ (i) $10x^5$
- 3 (a) 3^{2x} (b) 5^{x+11} (c) 5^{2m+1}
 (d) 3^{x-y} (e) 2^{3n-1} (f) a^{m+3}
 (g) $\frac{m^3n^2}{4}$ (h) $\frac{3(a+b)^3}{x^6}$ (i) $\frac{m^5}{n^2(m^2)}$
- 4 (a) $\frac{1}{a^2}$ (b) x^4 (c) $\frac{1}{n^{15}}$
 (d) $\frac{p^{12}}{8}$ (e) $\frac{3}{x^9}$ (f) $\frac{15}{ab^4}$
- 5 (a) 2 (b) 4 (c) 100
 (d) 625 (e) 27 (f) 0.2
 (g) 0.1 (h) 8 (i) 0.17
- 6 (a) p^4 (b) $m^{1/2}$ (c) $4n^{3/2}$
 (d) $4p^2$ (e) $m^{-7/6}$ (f) a^2
 (g) $4n^2$ (h) m^3n^2 (i) $4a^8b^{12}$
- 7 (a) 5 (b) 3 (c) 0.1 or
 (d) 0.06 or $\frac{1}{16}$ (e) 9 (f) 0.13 or
 (g) 5 (h) 0.36 (i) 0.1 or
 (j) 0.59 or $\frac{8}{27}$ (k) 6.06 or $\frac{81}{16}$ (l) 0.2 or
- 8 (a) $a^5 + 2a^2$ (b) $x^4 - 5x^2$
 (c) $n^5 + 3n^3$ (d) $10p^7 - 15p^4$
 (e) $2x^5 - 3x^2y^2$ (f) $35m^3n + 14mn^2$
 (g) $a^6 - 1$ (h) $x^4 + 2x^2 - 3$
 (i) $6m^4 + 13n^2 - 5n^4$