

Name: _____ Class: _____

St George Girls High School

Year 9

Common Test 1

May 2008



Mathematics

Time Allowed: 75minutes

Marks 74

Instructions:

- Set out work clearly
- Show all working when required.
- Calculators may be used.

	Marks
Section A	/20
Section B	
Question 1	/13
Question 2	/13
Question 3	/14
Question 4	/14
Total	/74

SECTION A

20 questions - 1 mark each.
 (Answers only in the ANSWER column).

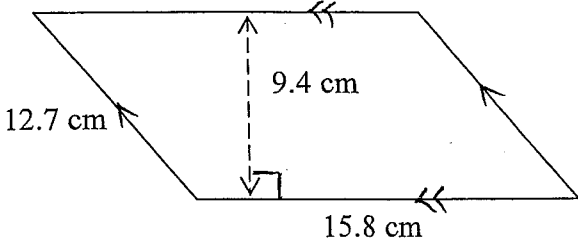
QUESTION	ANSWER																				
1. Expand $5x(2x - 7)$																					
2. Express 3 570 000 in scientific notation																					
3. Find the area of the parallelogram  NOT DRAWN TO SCALE																					
4. This spreadsheet shows winners of a book award <table border="1" data-bbox="252 1370 1007 1576"> <thead> <tr> <th></th> <th>A</th> <th>B</th> <th>C</th> </tr> </thead> <tbody> <tr> <td>1</td> <td>Year</td> <td>Author</td> <td>Title</td> </tr> <tr> <td>2</td> <td>2001</td> <td>Frances Clarke</td> <td>A Town's Lament</td> </tr> <tr> <td>3</td> <td>2002</td> <td>Jill Saunders</td> <td>Kitten and Snake</td> </tr> <tr> <td>4</td> <td>2003</td> <td>Jeff Hardy</td> <td>The Quiet Room</td> </tr> </tbody> </table> <p>What is the content of cell B3?</p> <p>(A) 2003 (B) Jill Saunders (C) Kitten and Snake (D) Jeff Hardy</p>		A	B	C	1	Year	Author	Title	2	2001	Frances Clarke	A Town's Lament	3	2002	Jill Saunders	Kitten and Snake	4	2003	Jeff Hardy	The Quiet Room	
	A	B	C																		
1	Year	Author	Title																		
2	2001	Frances Clarke	A Town's Lament																		
3	2002	Jill Saunders	Kitten and Snake																		
4	2003	Jeff Hardy	The Quiet Room																		
5. Solve the equation. $\frac{5n+3}{6} = 8$																					

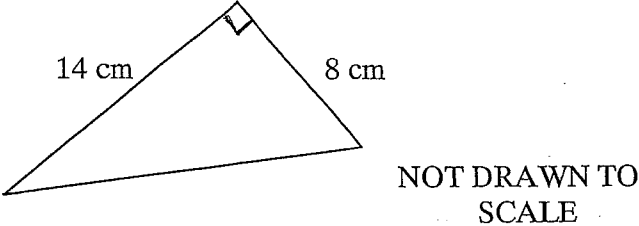
QUESTION	ANSWER
6. Change $8 \cdot 104 \times 10^{-7}$ to its basic numeral	
7. Find the perimeter of the triangle (1 decimal place) 	
8. Write $\sqrt[4]{y^3}$ in full index notation	
9. Solve the equation. $(y + 5)^2 = 36$	
10. Estimate the result of 9.476×17.489	
11. Factorise fully $12m^3 - 9m^2$	
12. Change the subject of the equation to m . $k = mn - y$	
13. A rectangular swimming pool is 25 metres long by 8 metres wide and is surrounded by a path of width 1 metre. What is the perimeter around the outside edge of the path?	

QUESTION	ANSWER																																								
<p>14. The students of Jones High School need to purchase their own textbooks. This spreadsheet shows the cost of each textbook to be purchased by Felicity Howard, a year 9 student.</p> <table border="1" style="margin: 10px auto; border-collapse: collapse; text-align: center;"> <thead> <tr> <th style="width: 5%;"></th> <th style="width: 30%;">A</th> <th style="width: 30%;">B</th> <th style="width: 35%;">C</th> </tr> </thead> <tbody> <tr> <td>1</td> <td>Felicity Howard</td> <td></td> <td></td> </tr> <tr> <td>2</td> <td></td> <td></td> <td></td> </tr> <tr> <td>3</td> <td>Textbook</td> <td>Price</td> <td></td> </tr> <tr> <td>4</td> <td>Mathematics</td> <td>\$42.85</td> <td></td> </tr> <tr> <td>5</td> <td>English</td> <td>\$31.45</td> <td></td> </tr> <tr> <td>6</td> <td>Science</td> <td>\$64.95</td> <td></td> </tr> <tr> <td>7</td> <td>History</td> <td>\$23.95</td> <td></td> </tr> <tr> <td>8</td> <td>Creative Arts</td> <td>\$18.00</td> <td></td> </tr> <tr> <td>9</td> <td></td> <td></td> <td></td> </tr> </tbody> </table> <p>If the formula =B4+B5+B6+B7+B8 is entered into cell B1, what value is shown in B1?</p>		A	B	C	1	Felicity Howard			2				3	Textbook	Price		4	Mathematics	\$42.85		5	English	\$31.45		6	Science	\$64.95		7	History	\$23.95		8	Creative Arts	\$18.00		9				
	A	B	C																																						
1	Felicity Howard																																								
2																																									
3	Textbook	Price																																							
4	Mathematics	\$42.85																																							
5	English	\$31.45																																							
6	Science	\$64.95																																							
7	History	\$23.95																																							
8	Creative Arts	\$18.00																																							
9																																									
<p>15. A rhombus has one diagonal equal to 12 cm and has an area of 78 cm². What is the length of the other diagonal?</p>																																									
<p>16. Express 27 kg/h in g/s.</p>																																									
<p>17. Simplify by expanding the brackets.</p> $(27x^6y^3)^{\frac{1}{3}}$																																									

Questions 18. and 19. relate to the following spreadsheet.

This spreadsheet shows the times taken for a group of students to each walk 50 metres. The speed of each student was calculated using a formula.

	A	B	C
1	Name	Time(s)	Speed (m/s)
2	Sarah	25	2.00
3	Ben	22	2.27
4	Alex	27	1.85
5	Cynthia	30	1.67
6	Rhys	18	2.78
7	Michael	19	2.63
8	Ellen	20	2.50
9	Maria	16	3.13

18. What formula could be entered into cell C2 to get the result shown (the formula must use a cell address)?

19. After entering the formula into cell C2, which option allowed the formula to be copied into the remaining cells?

- (A) Cut and Paste (C) Fill Down
(B) Replace (D) Sort

20. Write the inequality that is represented by the diagram

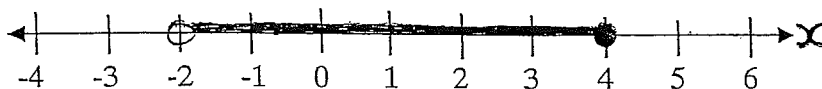

End of Section A

SECTION B

Show all necessary working in the space provided.

MARKS

Question 1 – (13 marks) Rational Numbers – Show all working

(a) Evaluate giving your answer in scientific notation correct to 3 significant figures.

(i) $4.86 \times 10^{-3} + 5.97 \times 10^{-2}$

2

(ii) $3.75 \times 10^6 \div 6.28 \times 10^{10}$

2

(b) A worker in a local factory earns \$12.72 per hour.

(i) How much does she earn in a 40 hour week?

1

(ii) If she receives the same amount for the week's work but only works a 38 hour week, what will be her new hourly rate to the nearest cent?

1

(c) The temperature at 2:30 pm was 11°C and fell steadily until it reached -2°C at 1:45 am. Find the average rate of decrease per hour correct to 2 decimal places.

2

Question 1 (cont'd)

MARKS

(d) 18 litres of petrol are needed for a car to travel 261 km.

(i) How far would the same car travel on 13 litres of petrol?

1

(ii) How much petrol would the car use to travel 340 km?

1

(e) For the calculation $\frac{4.76 + (5.2)^2}{3.87}$

(i) Find the upper and lower boundary estimates

2

(ii) Calculate the answer correct to 2 decimal places.

1

Question 2 – (13 marks) Measurement – Show all working

MARKS

- (a) A circular path with diameters is shown in the diagram. Find the shaded area correct to 3 significant figures.

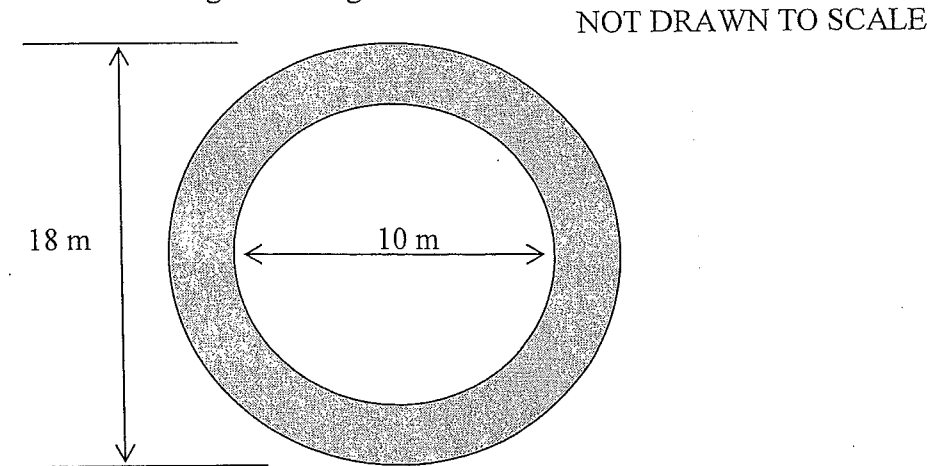

- (b) A rectangular sheet of metal has a semicircle cut out of one side as shown. Find the perimeter correct to the nearest metre.

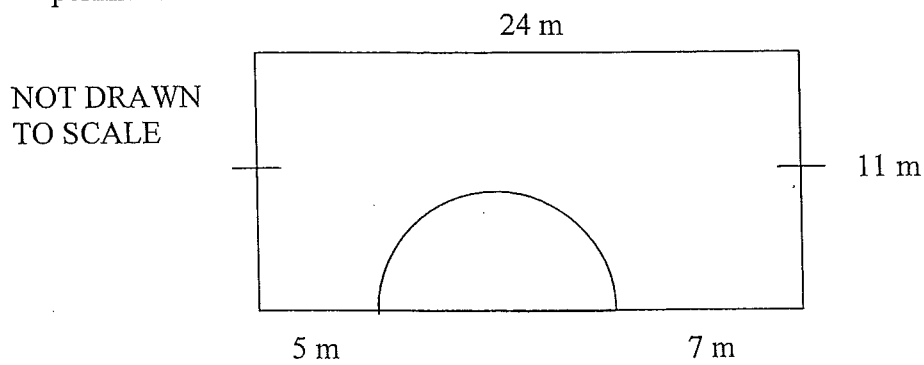

Question 2 (cont'd)

MARKS

- (c) Find the perimeter of the sector in centimetres correct to 2 decimal places.

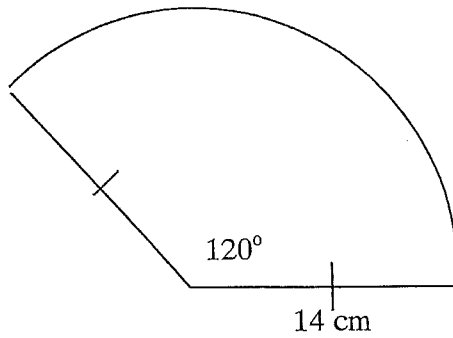

NOT DRAWN TO SCALE

2

- (d) Find the area of the composite shape in ~~mm~~^{cm²} correct to 2 decimal places.

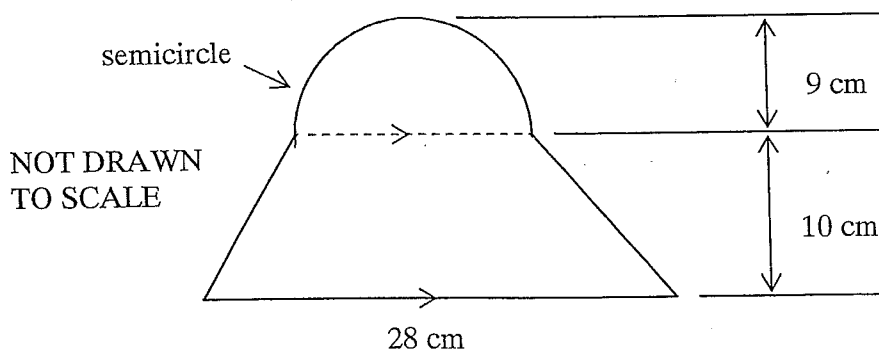

NOT DRAWN TO SCALE

Question 2 (cont'd)

MARKS

- (e) A circle and a square have the same area. If the radius of the circle is 8 cm, find the length of each side of the square in centimetres correct to 2 decimal places.

2

- (f) Find the size of the angle x° in the sector correct to the nearest degree if its area is 84 mm^2 .

NOT DRAWN TO SCALE

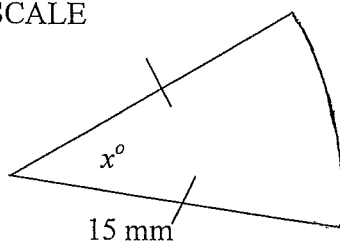

2

MARKS

Question 3 – (14 marks) Equations – Show all working

(a) Solve the equations

(i) $3(5x - 2) + 3x = 2(7x + 6)$

2

(ii) $\frac{2m}{3m-4} = \frac{3}{5}$

2

(b) Solve the inequation and display the solution on the number line.

$5 - 3x \leq -13$

2

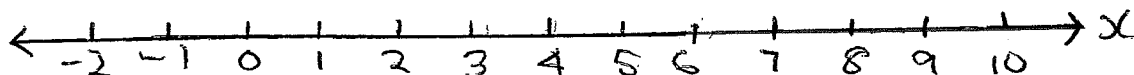

MARKS

Question 3 (cont'd)

(c) Given that $M = \frac{a^2 + b^2}{12}$ find a when $M = 97.15$ and $b = 19.65$

2

(d) Solve the inequation for x when we know that x is always positive

$$13 - 3x \geq 3 + 2x$$

2

(e) Gladys has only 20 cent pieces and 50 cent pieces in her purse. The total value of these coins is \$12.30. She has two less 50 cent pieces than 20 cent pieces. Use x to represent the number of 20 cent pieces and:

(i) Form an equation from the above information.

2

(ii) Solve the equation and state how many 20 cent pieces she has in her purse

2

MARKS

Question 4 – (14 marks) Algebra – Show all working

(a) Expand

(i) $(4x + 5)^2$

(ii) $\frac{-3}{4}n^2(4n^2 - 8n + 5)$

(b) Expand and simplify

(i) $2n(3n - 2) - 2(n - n^2)$

(ii) $n^2 - (2n + 1)(2n - 1)$

4

(c) Factorise fully

(i) $6m^2n - 12mn + 18mn^2$

(ii) $(3x + 1)(x + 1) + 5(x + 1)$

3

Question 4 (cont'd)

MARKS

(d) Simplify

(i) $(x^{-3})^{-2}$

(ii) $m^0 \div m$

(iii) $\frac{a^5 b^4 c^2 \times bc}{(abc^2)^3}$

3

(e) Find x

$9^x = 27$

2

End of Paper

SECTION A

20 questions - 1 mark each.
(Answers only in the ANSWER column).

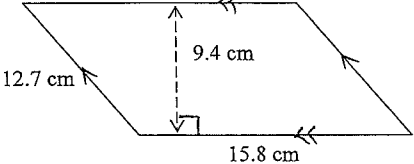
QUESTION	ANSWER																				
1. Expand $5x(2x-7)$ $= 10x^2 - 35x$	$10x^2 - 35x$ ✓																				
2. Express <u>3 570 000</u> in scientific notation	3.57×10^6 ✓																				
3. Find the area of the parallelogram  NOT DRAWN TO SCALE	9.4×15.8 $= 148.52 \text{ cm}^2$ ✓																				
4. This spreadsheet shows winners of a book award <table border="1" data-bbox="181 965 714 1114"> <thead> <tr> <th></th> <th>A</th> <th>B</th> <th>C</th> </tr> </thead> <tbody> <tr> <td>1</td> <td>Year</td> <td>Author</td> <td>Title</td> </tr> <tr> <td>2</td> <td>2001</td> <td>Frances Clarke</td> <td>A Town's Lament</td> </tr> <tr> <td>3</td> <td>2002</td> <td>Jill Saunders</td> <td>Kitten and Snake</td> </tr> <tr> <td>4</td> <td>2003</td> <td>Jeff Hardy</td> <td>The Quiet Room</td> </tr> </tbody> </table> What is the content of cell B3? (A) 2003 (B) Jill Saunders (C) Kitten and Snake (D) Jeff Hardy		A	B	C	1	Year	Author	Title	2	2001	Frances Clarke	A Town's Lament	3	2002	Jill Saunders	Kitten and Snake	4	2003	Jeff Hardy	The Quiet Room	✓
	A	B	C																		
1	Year	Author	Title																		
2	2001	Frances Clarke	A Town's Lament																		
3	2002	Jill Saunders	Kitten and Snake																		
4	2003	Jeff Hardy	The Quiet Room																		
5. Solve the equation. $\frac{5n+3}{6} = 8$	$5n+3=48$ $5n=45$ $n=9$ $n=9$ ✓																				



$$y^2 + 10y + 25 = 36$$

$$y^2 + 10y = 11$$

$$(y+5)(y+5)$$

$$= y(y+5) + 5(y+5)$$

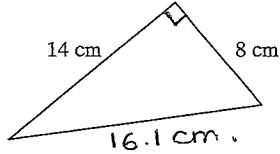
$$= y^2 + 5y + 5y + 25$$

QUESTION	ANSWER
6. Change $8 \cdot 104 \times 10^{-7}$ to its basic numeral	0.0000008104 ✓
7. Find the perimeter of the triangle (1 decimal place)  NOT DRAWN TO SCALE	38.1 cm ✓ (correct to 2 decimal place)
8. Write $\sqrt[4]{y^3}$ in full index notation	$y^{\frac{3}{4}}$ ✓
9. Solve the equation. $(y+5)^2 = 36$	$y^2 + 10y = 11$ ✓
10. Estimate the result of 9.476×17.489	9.5×17.5 $= 166.25$ ✓
11. Factorise fully $12m^3 - 9m^2$	$3m^2(4m-3)$ ✓
12. Change the subject of the equation to m . $k = mn - y$	$m = \frac{k+y}{n}$ ✓
13. A rectangular swimming pool is 25 metres long by 8 metres wide and is surrounded by a path of width 1 metre. What is the perimeter around the outside edge of the path? 	74m ✓

QUESTION			ANSWER																																								
<p>14. The students of Jones High School need to purchase their own textbooks. This spreadsheet shows the cost of each textbook to be purchased by Felicity Howard, a year 9 student.</p> <table border="1"> <thead> <tr> <th></th> <th>A</th> <th>B</th> <th>C</th> </tr> </thead> <tbody> <tr> <td>1</td> <td>Felicity Howard</td> <td></td> <td></td> </tr> <tr> <td>2</td> <td></td> <td></td> <td></td> </tr> <tr> <td>3</td> <td>Textbook</td> <td>Price</td> <td></td> </tr> <tr> <td>4</td> <td>Mathematics</td> <td>\$42.85</td> <td></td> </tr> <tr> <td>5</td> <td>English</td> <td>\$31.45</td> <td></td> </tr> <tr> <td>6</td> <td>Science</td> <td>\$64.95</td> <td></td> </tr> <tr> <td>7</td> <td>History</td> <td>\$23.95</td> <td></td> </tr> <tr> <td>8</td> <td>Creative Arts</td> <td>\$18.00</td> <td></td> </tr> <tr> <td>9</td> <td></td> <td></td> <td></td> </tr> </tbody> </table>				A	B	C	1	Felicity Howard			2				3	Textbook	Price		4	Mathematics	\$42.85		5	English	\$31.45		6	Science	\$64.95		7	History	\$23.95		8	Creative Arts	\$18.00		9				<p>\$181.20</p>
	A	B	C																																								
1	Felicity Howard																																										
2																																											
3	Textbook	Price																																									
4	Mathematics	\$42.85																																									
5	English	\$31.45																																									
6	Science	\$64.95																																									
7	History	\$23.95																																									
8	Creative Arts	\$18.00																																									
9																																											
<p>If the formula =B4+B5+B6+B7+B8 is entered into cell B1, what value is shown in B1?</p>			<p>✓</p>																																								
<p>15. A rhombus has one diagonal equal to 12 cm and has an area of 78 cm². What is the length of the other diagonal?</p>  $\frac{12 \times x}{2} = 78 \quad 12 \times x = 156 \quad x = 13$			<p>length of the other diagonal is 13 cm ✓</p>																																								
<p>16. Express 27 kg/h in g/s.</p> $\frac{27000 \text{ g/h}}{450 \text{ g/min}} = 7.5 \text{ g/s}$			<p>7.5 g/s ✓</p>																																								
<p>17. Simplify by expanding the brackets.</p> $(27x^6y^3)^{\frac{1}{3}}$ $3x^2y$			<p>3x²y ✓</p>																																								



<p>Questions 18. and 19. relate to the following spreadsheet.</p> <p>This spreadsheet shows the times taken for a group of students to each walk 50 metres. The speed of each student was calculated using a formula.</p> <table border="1"> <thead> <tr> <th></th> <th>A</th> <th>B</th> <th>C</th> </tr> </thead> <tbody> <tr> <td>1</td> <td>Name</td> <td>Time(s)</td> <td>Speed (m/s)</td> </tr> <tr> <td>2</td> <td>Sarah</td> <td>25</td> <td>2.00</td> </tr> <tr> <td>3</td> <td>Ben</td> <td>22</td> <td>2.27</td> </tr> <tr> <td>4</td> <td>Alex</td> <td>27</td> <td>1.85</td> </tr> <tr> <td>5</td> <td>Cynthia</td> <td>30</td> <td>1.67</td> </tr> <tr> <td>6</td> <td>Rhys</td> <td>18</td> <td>2.78</td> </tr> <tr> <td>7</td> <td>Michael</td> <td>19</td> <td>2.63</td> </tr> <tr> <td>8</td> <td>Ellen</td> <td>20</td> <td>2.50</td> </tr> <tr> <td>9</td> <td>Maria</td> <td>16</td> <td>3.13</td> </tr> </tbody> </table>			A	B	C	1	Name	Time(s)	Speed (m/s)	2	Sarah	25	2.00	3	Ben	22	2.27	4	Alex	27	1.85	5	Cynthia	30	1.67	6	Rhys	18	2.78	7	Michael	19	2.63	8	Ellen	20	2.50	9	Maria	16	3.13	
	A	B	C																																							
1	Name	Time(s)	Speed (m/s)																																							
2	Sarah	25	2.00																																							
3	Ben	22	2.27																																							
4	Alex	27	1.85																																							
5	Cynthia	30	1.67																																							
6	Rhys	18	2.78																																							
7	Michael	19	2.63																																							
8	Ellen	20	2.50																																							
9	Maria	16	3.13																																							
<p>18. What formula could be entered into cell C2 to get the result shown (the formula must use a cell address)?</p> <p>50 ÷ B2</p>		<p>50 ÷ B2 ✓</p>																																								
<p>19. After entering the formula into cell C2, which option allowed the formula to be copied into the remaining cells?</p> <p>(A) Cut and Paste (C) Fill Down (B) Replace (D) Sort</p>		<p>C ✓</p>																																								
<p>20. Write the inequality that is represented by the diagram</p> 		<p>-2 < x ≤ 4 ✓</p>																																								

End of Section A

SECTION B

Show all necessary working in the space provided.

MARKS

Question 1 – (13 marks) Rational Numbers – Show all working

(a) Evaluate giving your answer in scientific notation correct to 3 significant figures.

(i) $4.86 \times 10^{-3} + 5.97 \times 10^{-2}$

6.46×10^{-2} ✓

2

(ii) $3.75 \times 10^6 + 6.28 \times 10^{10}$

5.97×10^{-5} ✓

2

(b) A worker in a local factory earns \$12.72 per hour.

(i) How much does she earn in a 40 hour week?

$\$508.80$ ✓

1

(ii) If she receives the same amount for the week's work but only works a 38 hour week, what will be her new hourly rate to the nearest cent?

$\$13.40^{39}$ is her new hourly rate

1

$\frac{\$508.80}{38} = 13.39$ ✓

(c) The temperature at 2:30 pm was 11°C and fell steadily until it reached -2°C at 1:45 am. Find the average rate of decrease per hour correct to 2 decimal places.

fell 13°C

1.18° of decrease per hour

$13 \div 11.25$

(-1)

- ~~2:30~~
- 3:30
- 4:30
- 5:30
- 6:30
- 7:30
- 8:30
- 9:30

- 11:30
- 12:30
- 1:30

12 hrs.
+ 15 min



Question 1 (cont'd)

MARKS

(d) 18 litres of petrol are needed for a car to travel 261 km.

(i) How far would the same car travel on 13 litres of petrol?

$14.5 \text{ km/per litte}$

188.5 km ✓

1

(ii) How much petrol would the car use to travel 340 km?

23 litres
(rounded to whole number)

1

(e) For the calculation $\frac{4.76 + (5.2)^2}{3.87}$

(i) Find the upper and lower boundary estimates

$8.5 \sim 9.0$
 $7.5 \quad 8.5$
 $5 + 27 = \frac{32}{4} = 8$

2

$(-1\frac{1}{2})$

(ii) Calculate the answer correct to 2 decimal places.

8.22 ✓

1

Question 2 – (13 marks) Measurement – Show all working

MARKS

- (a) A circular path with diameters is shown in the diagram. Find the shaded area correct to 3 significant figures.

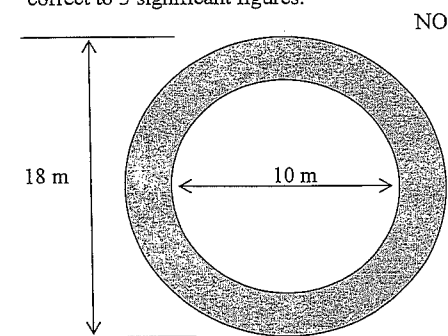

~~78.5 m²~~
 $254 \text{ m}^2 - 79 \text{ m}^2$
 $= 175 \text{ m}^2$ ✓
 $A = \pi R^2 - \pi r^2$
 $= \pi \times 9^2 - \pi \times 5^2$
 $= 175.929 \dots$ (-1)
 $\approx 176 \text{ m}^2$

- (b) A rectangular sheet of metal has a semicircle cut out of one side as shown. Find the perimeter correct to the nearest metre.

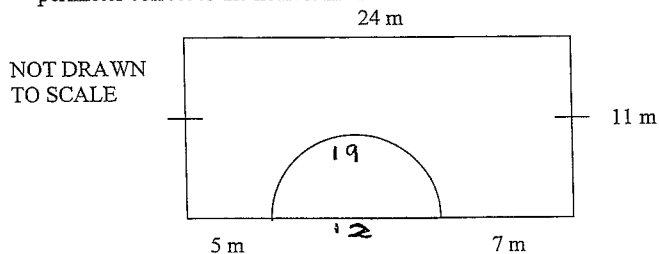

$11 + 24 + 11 + 7 + 19 + 5 = 77 \text{ m}$

∴ the perimeter is 77 m. ✓

Question 2 (cont'd)

MARKS

- (c) Find the perimeter of the sector in centimetres correct to 2 decimal places.

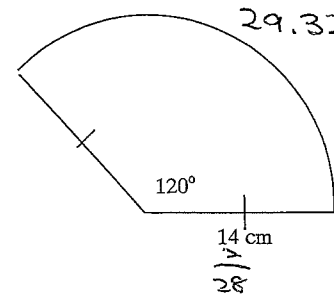

$29.32 + 14 + 14$
 $= 57.32 \text{ cm}$ ✓

- (d) Find the area of the composite shape in cm^2 correct to 2 decimal places.

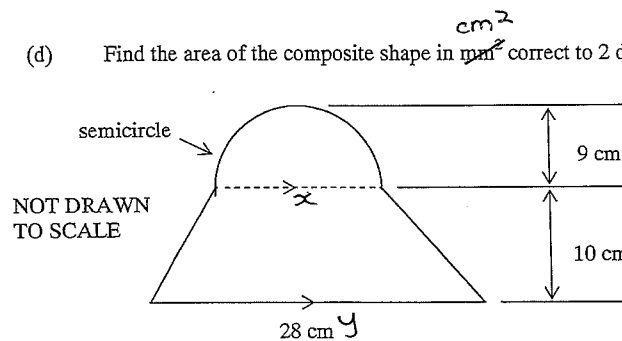

trapezium = $\frac{(x+y)h}{2} = \frac{(18+28)10}{2} = 230 \text{ cm}^2$

circle = $\frac{1}{2} \times \pi \times 9^2 = 127.23 \text{ cm}^2$

∴ total area is 357.23 cm^2 ✓

Question 2 (cont'd)

MARKS

- (e) A circle and a square have the same area. If the radius of the circle is 8 cm, find the length of each side of the square in centimetres correct to 2 decimal places.

$$\pi r^2 = 201.1 \text{ cm}^2$$

\therefore length of each side of the square is 14.18 cm (correct to 2 dp)

- (f) Find the size of the angle x° in the sector correct to the nearest degree if its area is 84 mm^2 .

NOT DRAWN TO SCALE

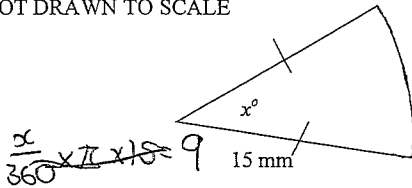

~~$$\frac{x}{360} \times \pi \times 15^2 = 84$$~~

$$84 \div 707 = 0.12 \times 360$$

$$= 43.2$$

$$\underline{43^\circ}$$

\therefore the size of the angle $x^\circ = 43^\circ$

Question 3 – (14 marks) Equations – Show all working

MARKS

- (a) Solve the equations

(i) $3(5x-2) + 3x = 2(7x+6)$

$$15x - 6 + 3x = 14x + 12$$

$$18x - 6 = 14x + 12$$

$$4x - 6 = 12$$

$$4x = 18$$

$$x = 4\frac{1}{2} \checkmark$$

(ii) $\frac{2m}{3m-4} = \frac{3}{5}$

$$2m \times 5 = 3(3m-4)$$

$$10m = 9m - 12$$

$$m = -12 \checkmark$$

- (b) Solve the inequation and display the solution on the number line.

$$5 - 3x \leq -13$$

$$-3x \leq -18$$

$$x \geq 6$$

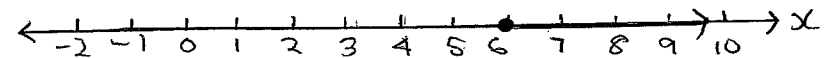

MARKS

Question 3 (cont'd)

- (c) Given that $M = \frac{a^2 + b^2}{12}$ find a when $M = 97.15$ and $b = 19.65$

$$97.15 = \frac{a^2 + 19.65^2}{12} \quad \checkmark \quad 2$$

$$1165.8 = a^2 + 19.65^2 \quad (-1)$$

$$1146.15 = a^2$$

$$\pm 33.85 = a \quad (\text{correct to 2 dp})$$

- (d) Solve the inequation for x when we know that x is always positive

$$13 - 3x \geq 3 + 2x$$

$$13 \geq 3 + 5x \quad 2$$

$$10 \geq 5x$$

$$2 \geq x$$

$$x \leq 2, \text{ but } x > 0 \quad (-1)$$

$$\therefore 0 < x \leq 2$$

- (e) Gladys has only 20 cent pieces and 50 cent pieces in her purse. The total value of these coins is \$12.30. She has two less 50 cent pieces than 20 cent pieces. Use x to represent the number of 20 cent pieces and:

- (i) Form an equation from the above information. 2

$$\begin{aligned} x + 50(x-2) &= 1230 \\ 20x + 50x - 100 &= 1230 \\ 20x + 50x &= 1330 \\ 70x &= 1330 \\ x &= 19 \end{aligned}$$

$$\begin{aligned} 20x + 50y &= 1230 \\ 18x + 50y &= 1230 \end{aligned}$$

$$20x + 50(x-2) = 1230$$

- (ii) Solve the equation and state how many 20 cent pieces she has in her purse. 2

$$\begin{aligned} 20x + 50(x-2) &= 1230 \\ = 20x + 50x - 100 &= 1230 \checkmark \\ = 20x + 50x &= 1330 \\ = 70x &= 1330 \\ = x &= 19 \end{aligned}$$

\therefore She has 19 20 cent pieces. \checkmark

MARKS

Question 4 - (14 marks) Algebra - Show all working

- (a) Expand

(i) $(4x+5)^2$

$$\begin{aligned} &(4x+5)(4x+5) \\ &= 4x(4x+5) + 5(4x+5) \\ &= 16x^2 + 20x + 20x + 25 \\ &= 16x^2 + 40x + 25 \quad \checkmark \end{aligned}$$

(ii) $\frac{-3}{4}n^2(4n^2-8n+5)$

$$\begin{aligned} &= \frac{-3}{4}n^2(4n^2-8n+5) \\ &= \frac{-3}{4}n^2(4n^2) + \frac{-3}{4}n^2(-8n) + \frac{-3}{4}n^2(5) \\ &= -3n^4 + 6n^3 - \frac{15}{4}n^2 \quad \checkmark \end{aligned}$$

- (b) Expand and simplify

(i) $2n(3n-2) - 2(n-n^2)$

$$\begin{aligned} &2n(3n-2) - 2(n-n^2) \\ &= 6n^2 - 4n - 2n + 2n^2 \\ &= 8n^2 - 6n \quad \checkmark \end{aligned}$$

(ii) $n^2 - (2n+1)(2n-1)$

$$\begin{aligned} &n^2 - (2n+1)(2n-1) \\ &= n^2 - (4n^2 - 1) \\ &= n^2 - 4n^2 + 1 \\ &= -3n^2 + 1 \quad \left(-\frac{1}{2}\right) \end{aligned}$$

- (c) Factorise fully

(i) $6m^2n - 12mn + 18mn^2$

$$6mn(m-2+3n) \quad \checkmark$$

(ii) $(3x+1)(x+1) + 5(x+1)$

$$\begin{aligned} &(3x+1)(x+1) + 5(x+1) \\ &= 3x^2 + 3x + x + 1 + 5x + 5 \\ &= 3x^2 + 9x + 6 \\ &= 3(x^2 + 3x + 2) = 3(x+1)(x+2) \quad (-1) \end{aligned}$$

You do need to expand first when factorising here.

Question 4 (cont'd)

MARKS

(d) Simplify

(i) $(x^{-3})^{-2}$

x^6 ✓

(ii) $m^0 \div m$

$1 \div m$

$\frac{1}{m}$ ✓

(iii) $\frac{a^2 b^4 c^2 \times bc}{(abc^2)^3}$

~~$a^2 b^5 c^3$~~

~~$a^2 b^3 c^6$~~

$\frac{a^2 b^2}{c^3}$ ✓

3

(e) Find x

$9^x = 27$

$3^{2x} = 3^3$

~~$27x = 3$~~

~~$x = 1$~~

$x = 1\frac{1}{2}$ or $1\frac{1}{2}$ ✓

2

End of Paper