



SOUTH SYDNEY HIGH SCHOOL

2001
School Certificate
Trial Examination

Mathematics

Section 2
Part A
Question Booklet

Directions for Section 2 Part A

- You are allowed 90 minutes to answer Part A and Part B of Section 2
- Section 2 has TWO parts
Part A: Questions 26 – 75 (50 marks)
Part B: Questions 76 – 84 (25 marks)
- Attempt ALL questions
- All questions in Part A are multiple choice
- Each question has only one correct answer
- Complete your answers on the grid provided on page 2
- Calculators MAY be used in this section
- The Formulae on page 4 of the Instruction Booklet may be used in section 2
- Write your answers in the space provided
- Write your student number and/or name at the top of every page

This paper **MUST NOT** be removed from the examination room

STUDENT NAME/NUMBER:

Part A

Total marks (50)

Attempt questions 26 – 75

Allow about 60 minutes for this part

Select the alternative A, B, C or D that best answers the question and indicate your choice with a cross (X) in the appropriate space on the grid below.

	A	B	C	D
26				
27				
28				
29				
30				
31				
32				
33				
34				
35				
36				
37				
38				
39				
40				
41				
42				
43				
44				
45				
46				
47				
48				
49				
50				

	A	B	C	D
51				
52				
53				
54				
55				
56				
57				
58				
59				
60				
61				
62				
63				
64				
65				
66				
67				
68				
69				
70				
71				
72				
73				
74				
75				

Complete your answers to Questions 26 – 75 on the Multiple Choice Answer Sheet.

26 Evaluate $120 \div 4 \times 5 - 11$

- (A) -5 (B) 17 (C) 139 (D) 161

27 What number is half way between -8 and 20 ?

- (A) -14 (B) 6 (C) 13.5 (D) 14

28 Name the solid given below :

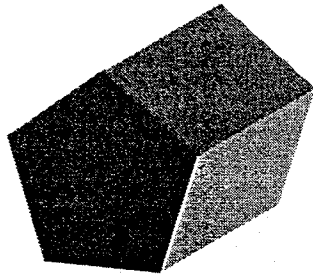

- (A) Hexagonal Prism
 (B) Hexagonal Pyramid
 (C) Pentagonal Prism
 (D) Rectangular Pentagon

29 Simplify $8m + 3n - 4m - 7n$

- (A) $4m + 10n$ (B) $4m + 4n$ (C) $4m - 10n$ (D) $4m - 4n$

30 The table below shows the highest and lowest temperatures for each day last week.

Day	Highest Temperature	Lowest Temperature
Sunday	28°	21°
Monday	35°	24°
Tuesday	32°	25°
Wednesday	29°	19°
Thursday	36°	27°
Friday	31°	23°
Saturday	33°	18°

What is the difference between the highest temperature recorded and the lowest temperature recorded last week ?

- (A) 15° (B) 16° (C) 17° (D) 18°

- 31 The end of a box is made up of a rectangle and an isosceles triangle.

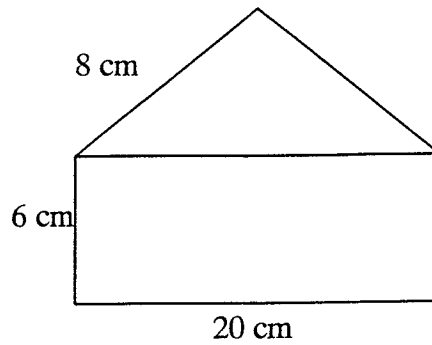

The perimeter of the end of the box is :

- (A) 34 cm (B) 42 cm (C) 48 cm (D) 68 cm
- 32 In which diagram is $\frac{2}{3}$ of the whole figure shaded ?

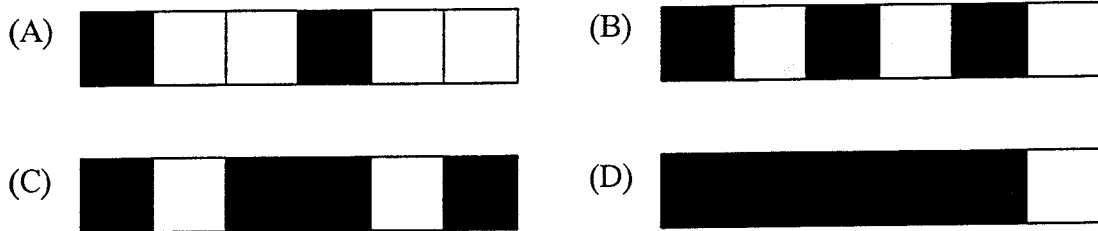

- 33 A wooden crate holds 1 000 bricks.
The total mass of the wooden crate and the bricks is 816 kg.
If the wooden crate has a mass of 16 kg, then each brick has a mass of :

- (A) 80 grams (B) 81.6 grams (C) 800 grams (D) 816 grams

- 34 Which number is three less than the number $5w - 4$?

- (A) $2w - 4$ (B) $-2w$ (C) $2w - 1$ (D) $5w - 7$

- 35 Gregory writes 36 e-mails in one month to family and friends that live overseas.
During this month he made a total of 48 e-mails to family and friends.

What percentage of the e-mails are not for family and friends living overseas ?

- (A) 12 % (B) 25 % (C) 52 % (D) 75 %

36 Which of the angles shown is more than two right angles ?

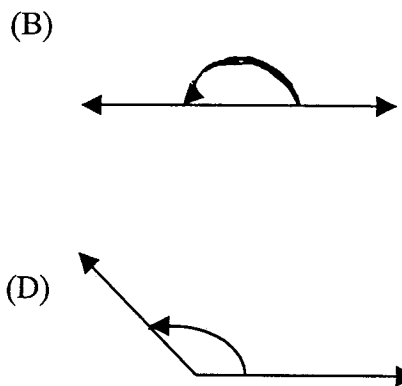
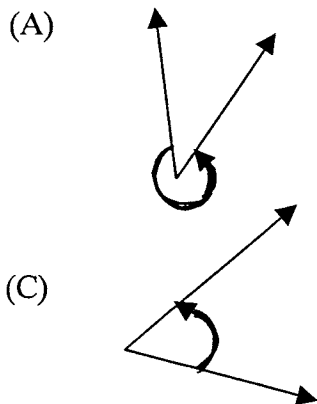

37 The average height of seven netball players is 180 cm.
Mary is 188 cm, Sylvia is 176 cm, Tina is 182 cm and Raluca is 175 cm.

The heights of the remaining three players could be :

- (A) 180 cm, 180 cm, 180 cm (B) 180 cm, 179 cm, 178 cm
(C) 181 cm, 180 cm, 179 cm (D) 182 cm, 180 cm, 177 cm

38 Jenny collected \$800 when she delivered empty cans.

What was the total mass of the empty cans she delivered ?

- (A) 0.5 kg (B) 2.5 kg
(C) 200 kg (D) 2 tonnes

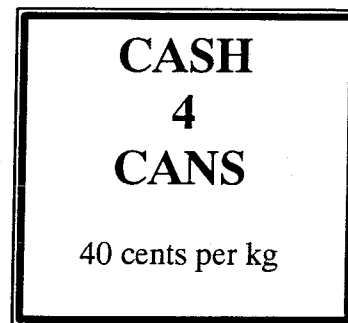

39 Which of the following statements are true about a rhombus ?

- (A) When one diagonal of a rhombus is drawn it divides the rhombus into two equilateral triangles.
(B) When one diagonal of a rhombus is drawn it divides the rhombus into two scalene triangles.
(C) When two diagonals of a rhombus are drawn it divides the rhombus into four right-angled triangles.
(D) When two diagonals of a rhombus are drawn it divides the rhombus into four isosceles triangles.

- 40 The table below shows four types of blood groups in Australia.

Blood groups in Australia	
Blood group	Number of people
AB	618 250
A	8 825 000
B	2 003 000
O	7 857 200

Which of these blood groups have more than two and a half million people ?

- (A) AB and B (B) A and O (C) A, B and O (D) All blood groups.
- 41 New York (USA) is 5 hours behind London (UK) and Perth (Australia) is 8 hours ahead of London. What time is it in New York if it is 2 pm in Perth ?
- (A) 1 am (B) 11 am (C) 1 pm (D) 5 pm
- 42 A triangle has its angles in the ratio of 1 : 2 : 3. What is the difference between the largest and smallest angles ?
- (A) 2° (B) 30° (C) 60° (D) 90°
- 43 Solve $4a - 6 = 42$
- (A) $a = 9$ (B) $a = 12$ (C) $a = 36$ (D) $a = 48$
- 44 The top of a pyramid has been removed as shown.

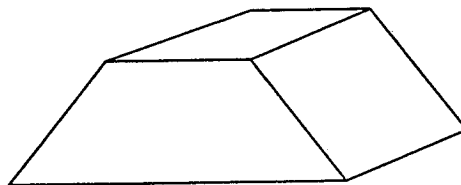

What solid has been removed from the pyramid ?

- (A) rectangle (B) rectangular prism
(C) rectangular pyramid (D) triangular prism

45 Kevin needs to buy acid for his pool.

Which of the following represents the best value for money ?

- (A) 150 mL for \$2.35 (B) 250 mL for \$4.75
 (C) 1.25 L for \$ 19.40 (D) 2 L for \$31.20

46 A hardware shop sells 4mm thick plywood sheets.
 There is a stack of these plywood sheets 1.52 metres high.

How many plywood sheets are in the stack ?

- (A) 38 (B) 380 (C) 608 (D) 3 800

47 The cost (C) of a mobile phone each month is given by the formula :
 $C = 25 + 0.8 \times M$, where M is the amount of minutes used on a mobile phone each month.
 Nicole receives a monthly mobile phone statement of \$45.

How many minutes did she use on her mobile phone for this statement ?

- (A) 20 minutes (B) 25 minutes (C) 45 minutes (D) 50 minutes

48 The graph shows the number of people living in each unit in a block of flats.

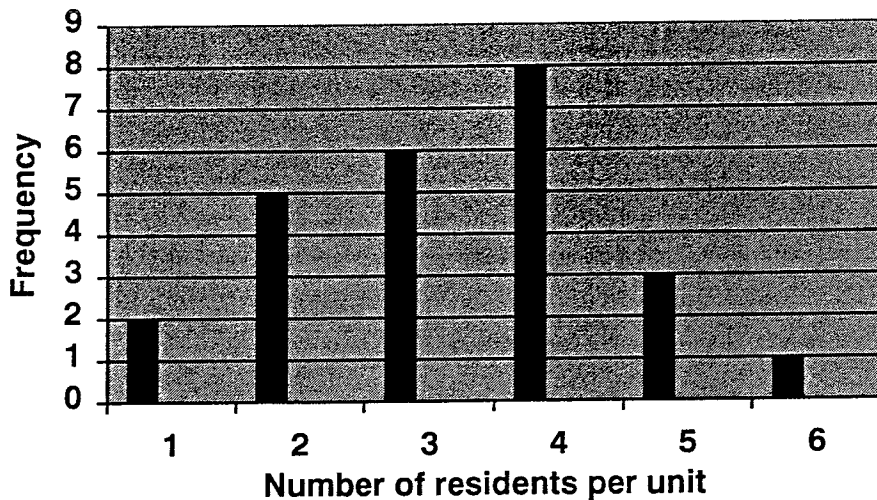

What is the probability of selecting a unit with two residents ?

- (A) $\frac{1}{5}$ (B) $\frac{1}{6}$ (C) $\frac{7}{25}$ (D) $\frac{18}{25}$

- 49 A 3 metre high flag pole has been painted 90 cm from the base.
 What fraction of the pole has not been painted ?

- (A) $\frac{1}{3}$ (B) $\frac{2}{3}$
 (C) $\frac{3}{10}$ (D) $\frac{7}{10}$

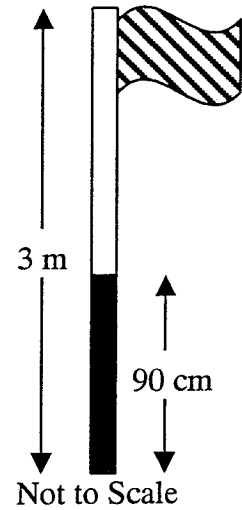

- 50 A train leaves a station at 9:15 pm and arrives at its destination at 2:35 pm the next day.
 How long did it take for the journey ?

- (A) 17 hours 20 minutes (B) 11 hours 50 minutes
 (C) 6 hours 40 minutes (D) 5 hours 40 minutes

51

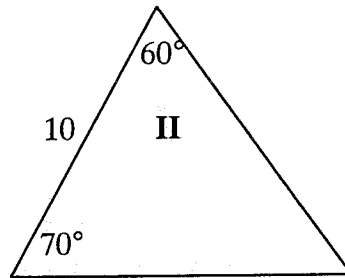
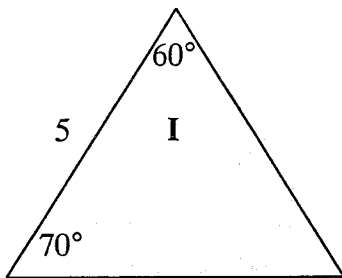

Which of the following statements is true ?

- (A) I and II are congruent only. (B) I and II are similar only.
 (C) I and II are both congruent and similar. (D) I and II are neither congruent or similar.
- 52 Mario is an Olympic wrestler with $\frac{5}{8}$ of his mass being 80 kg.
 His total mass is :
- (A) 30 kg (B) 50 kg (C) 110 kg (D) 128 kg

53

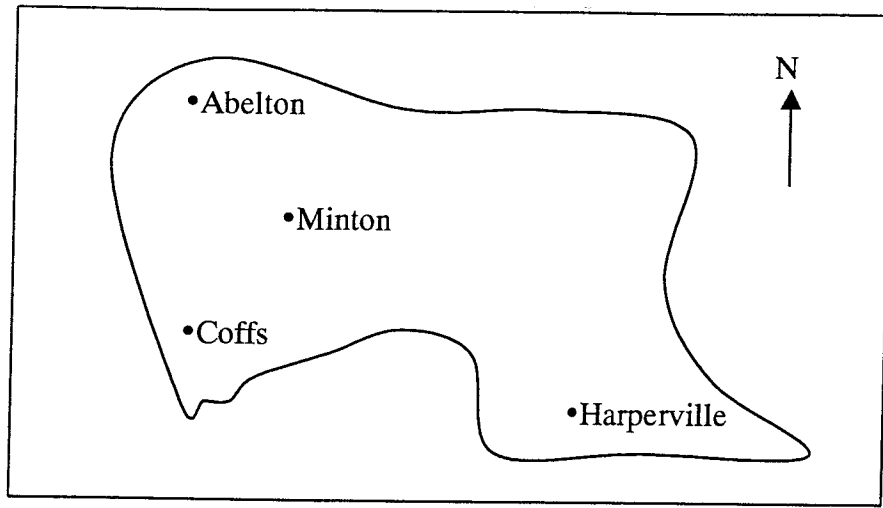

Using the above map, which of the following is true ?

- (A) Coffs is east of Harperville (B) Minton is south-east of Abelton
 (C) Abelton is north-east of Harperville (D) Harperville is south-west of Coffs

54 Which solid has a capacity of one litre ?

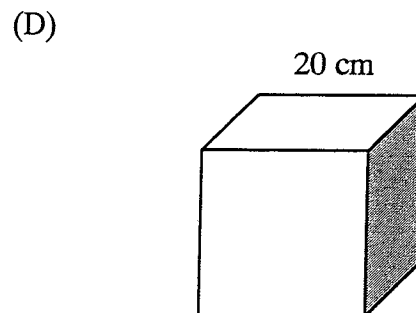
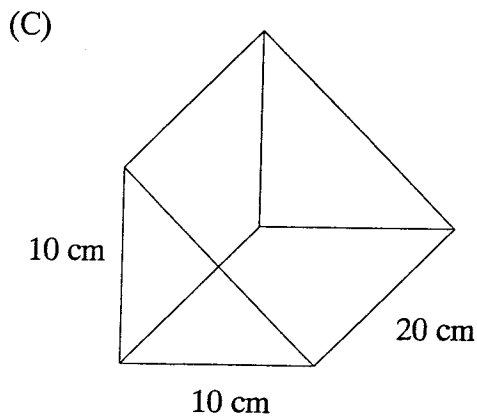
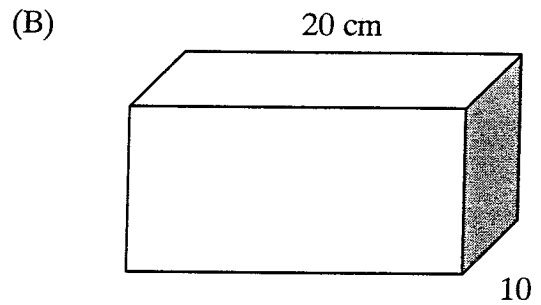
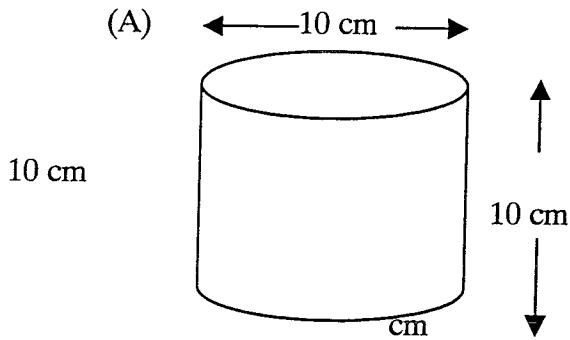

55 Simplify $a^2 + a^2$

(A) a^4

(B) $2a^2$

(C) $2a^4$

(D) $4a^4$

56

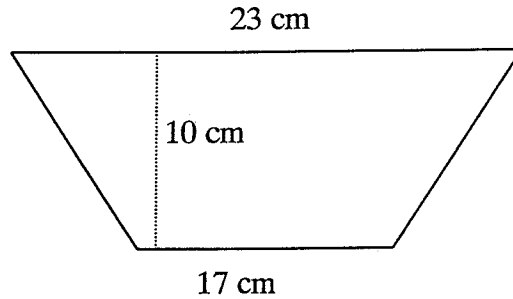
NOT TO
SCALE

Calculate the area of this trapezium.

(A) 45 cm^2

(B) 50 cm^2

(C) 200 cm^2

(D) 400 cm^2

57 Anna scores 16, 15, 12 and 18 points in the first four matches for the year.
After five matches her mean is 16 points.

What is the range after five matches ?

(A) 6

(B) 7

(C) 19

(D) 68

58

x	0	2	4	6	8
y	1	7	13	19	25

What is the correct rule for this table of values ?

(A) $y = x + 1$

(B) $y = x + 6$

(C) $y = 6x + 1$

(D) $y = 3x + 1$

59 Petrol costs 86.3 cents per litre. Kylie needs 65 litres to fill her tank.

How much does this cost Kylie ?

(A) \$56.09

(B) \$56.10

(C) \$560.95

(D) \$5609.50

60 A crowd of approximately 91 000 attended a Tri-Nations rugby match.

This numeral in scientific notation is :

- (A) 9.1×10^{-3} (B) 9.1×10^{-4} (C) 9.1×10^3 (D) 9.1×10^4

61 Ninety-six small cubes can fit exactly inside the large box with a square end.

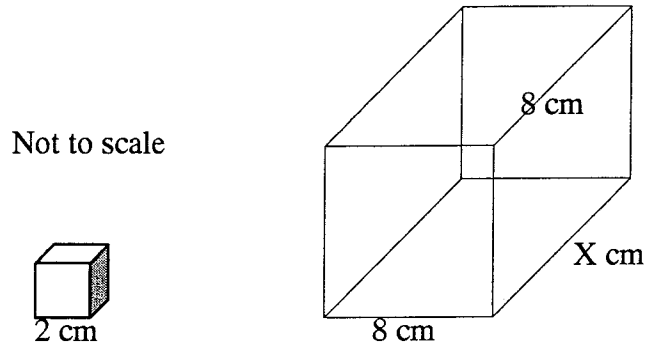

The value of X is :

- (A) 6 (B) 12 (C) 16 (D) 48

62 Which circle has a radius and a chord ?

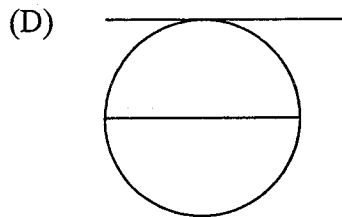
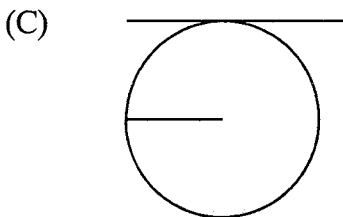
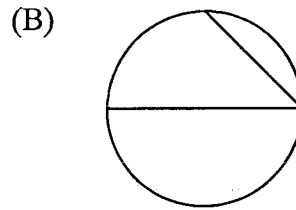
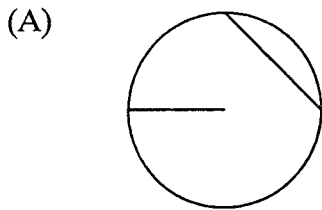

63 Which line could pass through the point $(-3, -2)$?

- (A) PQ (B) KL
 (C) AB (D) MN

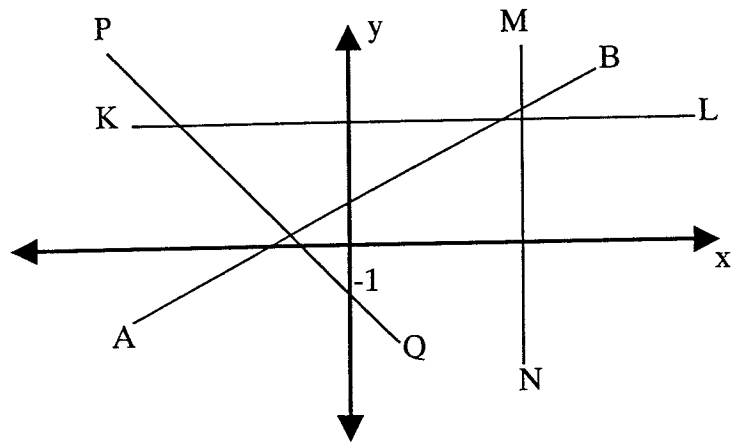

64 Four equal size blocks are used to make each of the solids.

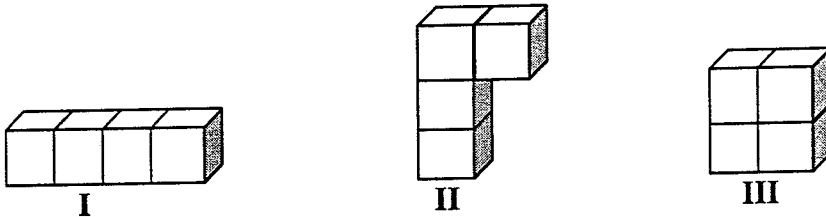

Which solid has the smallest surface area ?

- (A) I (B) II (C) III (D) They are all equal.

65 In a squash tournament, players need to win their matches to progress through to the next round.

If there are 32 players in the tournament, how many matches are played to determine a winner ?

- (A) 5 (B) 8 (C) 16 (D) 31

66 It takes 6 minutes for the sand of an egg timer to fill the bottom half of the egg timer.

Every 5 seconds 10 grams of sand pour into the bottom half of the egg timer.

The amount of sand in the egg timer is :

- (A) 120 grams (B) 300 grams (C) 360 grams (D) 720 grams

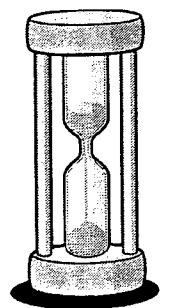

67 The area of the triangle PQR is 24 square units.

The length of PQ is :

- (A) 8.5 (B) 8.9
 (C) 10 (D) 13

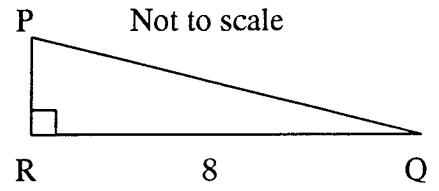

68 A mountain bike wheel has a diameter of 80 cm.
 Approximately how far does this mountain bike travel with 50 revolutions of the wheel ?

- (A) 40 m (B) 126 m (C) 250 m (D) 4 000 m

69 Two years ago Tom was twice Rhonda's age.
 Rhonda is now 13 years old, how old is Tom now ?

- (A) 22 (B) 24 (C) 26 (D) 28

70 The diameter PQ of the large circle with centre O is 48 cm.
 The point R lies on the circumference of the large circle.
 The angle POR is a right angle.

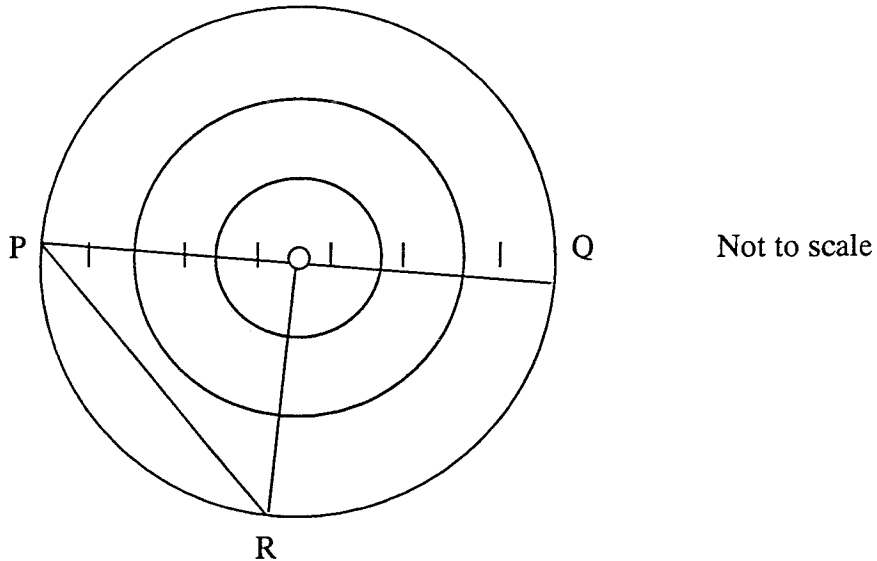

What is the area of triangle POR ?

- (A) 24 cm^2 (B) 36 cm^2 (C) 48 cm^2 (D) 288 cm^2

- 71 The small oil drum can be completely filled 33 times with the oil from the large drum, with 25 mL of oil remaining in the large drum.

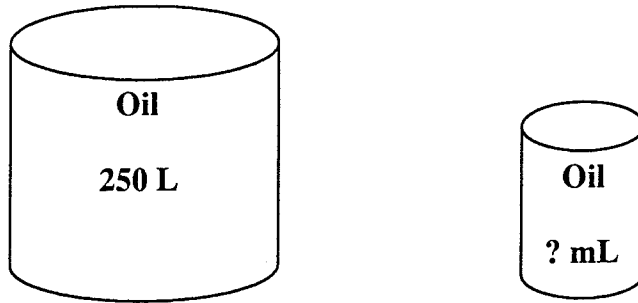

What is the capacity (in millilitres) of the small drum ?

- (A) 7.575 mL (B) 75.75 mL (C) 757.5 mL (D) 7575 mL
- 72 A piece of cardboard with an area of 48 cm^2 is cut vertically into two pieces A and B as shown.

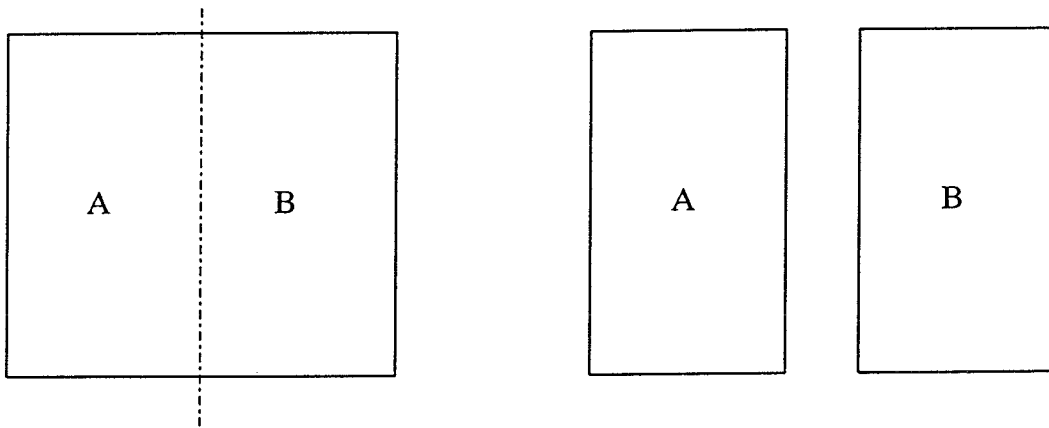

Each cut piece has a perimeter of 22 cm.

What is the perimeter of the original piece of cardboard ?

- (A) 48 cm (B) 36 cm (C) 28 cm (D) 24 cm
- 73 A man died in 1826 aged 82 years old.
His son was born in the year the man was 21 years old.
- In what year was the man's son 21 years old ?
- (A) 1784 (B) 1786 (C) 1796 (D) 1805

74 The sector graph shows distribution of the profit from compact disc sales.

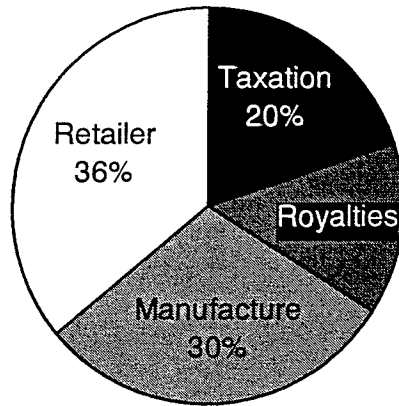

If the compact disc sells for \$25, how much does the artist receive in royalties ?

- (A) \$14 (B) \$11 (C) \$6.20 (D) \$3.50

75 On a game board, a counter is a position (F, c) and can be moved in any direction.

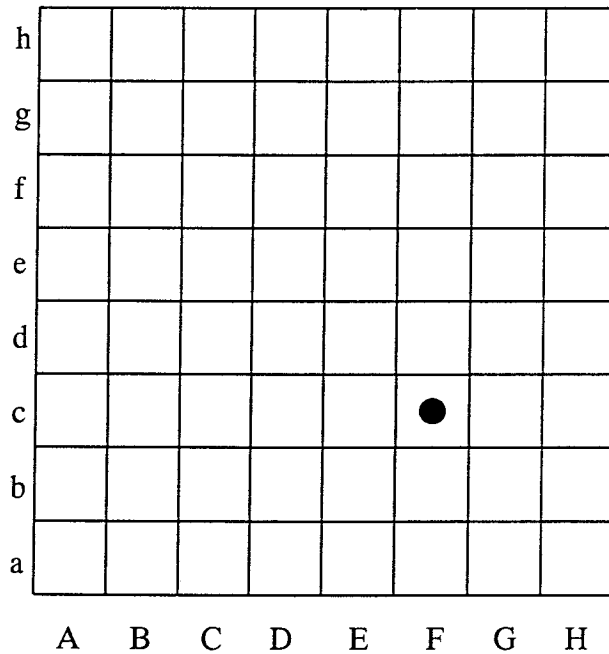

A player decides to move the counter 4 squares.

The new position of the counter could be :

- (A) (H, g) (B) (C, f) (C) (H, f) (D) (A, h)

**End of Section 2 Part A
Go to Part B**