

Student Name / Number _____

Preliminary Course Final Examination

2000 MATHEMATICS

Instructions :

**Time Allowed: 2 hours
(Plus 5 mins reading time)**

- Attempt ALL questions.
- ALL questions are of equal value.
- All necessary working should be shown.
- Marks may be deducted for poorly arranged or missing working.
- Use a SEPARATE Writing Booklet for each question.
- Write your Name / Student Number on every page.
- Board-approved calculators may be used.

Question 1 (12 marks)	Start a NEW page.	Marks
(a)	Find $\sqrt[4]{2 \cdot 8385}$ correct to 5 significant figures	2
(b)	Simplify $\frac{3}{4} - \frac{2x-1}{3}$	2
(c)	Differentiate $5x^8 + 14x - 2$	2
(d)	Factorise completely $4x^3 - 4x^2 - 9x + 9$	2
(e)	John invests \$800 at 4% per annum with interest compounded monthly. Calculate the value of the investment after 3 years.	2
(f)	Solve $2 - 5x > 9$	2

Continue next page

Question 2(12 marks)

Start a NEW page.

	Marks
(a) Differentiate: $(3x^2 - 5x)^3$.	2
(b) Find the primitive of $3 - 2x^2$.	2
(c) Given $f(x) = 1 - x^3$, find the value of 'a' if $f(a) = 65$.	2
(d) Find the values of a and b if $\frac{1}{2\sqrt{3}-1} = a + b\sqrt{3}$.	2
(e) The roots of the quadratic equation $3x^2 + 4x + 2 = 0$ are α and β . Find the value of $2\alpha + 2\beta$.	2
(f) Simplify $\frac{4-x^2}{6-x-x^2}$.	2

Continue next page ...

Question 3 (12 marks)

Start a NEW page.

Marks

- (a) Find the first two terms of an Arithmetic sequence if the eighth term, $T_8 = 17$ and the eighteenth term, $T_{18} = 32$. **2**

- (b) Find the coordinates of the points on the curve $y = x^3 + 3x^2$ where the tangent is parallel to the line $y = 9x - 5$. **4**

- (c) Jack and Jessie are throwing a party. During the party the doorbell rang 9 times. The first time the bell rang, only one guest arrived. Each time the bell rang after that, twice as many guests arrived than at the previous bell. How many guests were at the party? **3**

- (d) In the diagram below $AB \parallel CD$ and $AE = AC$, $\angle DCE = 40^\circ$. **3**

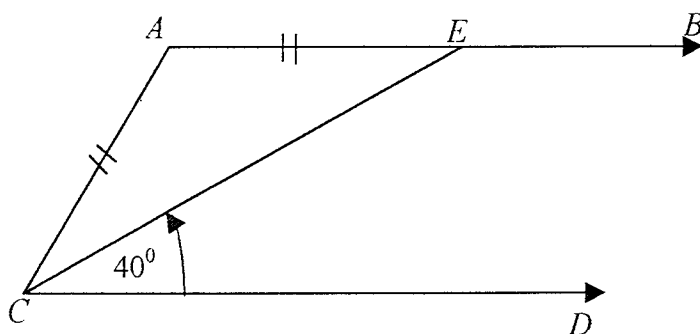

Not to scale

Copy the diagram into your Writing Booklet.
Find the size of $\angle BAC$, giving reasons.

Continue next page ...

Question 4 (12 marks)

Start a NEW page.

Marks

- (a) (i) Sketch the graph of $y = 3 - x^2$ and label all intercepts with the axes. **1**
- (ii) On the same axes, sketch carefully the graph of $y = |2x|$. **1**
- (iii) Use your sketch or otherwise, determine the coordinates of the two points P and Q where the graphs intersect. **2**

- (b) **8**

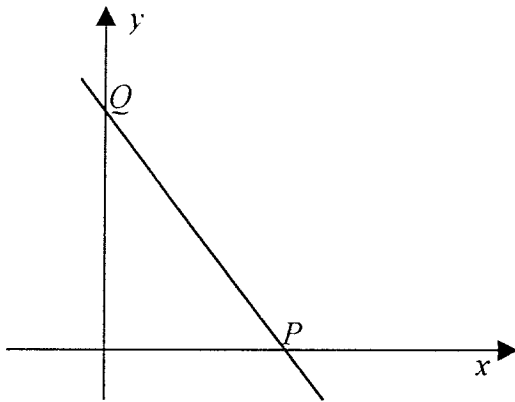

In the diagram above, P and Q are the points on the x and y intercepts respectively. O is the origin. The equation of PQ is $4x + 3y - 12 = 0$.

Copy the diagram into your Writing Booklet.

- (i) Find the coordinates of P and Q .
- (ii) If $\angle OPQ = \theta$, find θ (correct to the nearest minute).
- (iii) Show that the gradient of PQ is $-\frac{4}{3}$.
- (iv) Point R lies on PQ such that OR is perpendicular to PQ . Find the equation of OR .
- (v) Draw the line OR on your sketch and shade in triangle OQR . Write down three inequalities satisfying the shaded region, including the boundaries.

Continue next page

Question 5 (12 marks)

Start a NEW page.

Marks

- (a) Consider the curve given by the equation $y = 6x^2 - x^3$. 7
- (i) Find the coordinates of the stationary points and determine their nature.
 - (ii) Find the coordinates of any points of inflexion.
 - (iii) State the x -intercepts.
 - (iv) Draw a neat sketch of the curve $y = 6x^2 - x^3$.
 - (v) State the values of x for which the curve is concave up.
- (b) The discriminant of $3x^2 - kx + 3$ is $k^2 - 36$. 2
For what values of k does $3x^2 - kx + 3 = 0$ have no real roots?
- (c) Four metallic disks, numbered 1,2,3 and 4 are placed in a bag. 3
Two disks are selected at random and placed together on a table to form a two digit number.
- (i) By using a tree diagram, or otherwise, find how many two digit numbers can be formed.
 - (ii) Determine the probability that the number formed is divisible by 3.

Continue next page

Question 6 (12 marks)

Start a NEW page.

Marks

(a) Find :

5

(i) $\int (4x^3 - 3x^2 + 2x + 5) dx$

(ii) $\int_1^2 (x+1)(x-3) dx$

(iii) $\int \left(x - \frac{1}{x^2} \right) dx$

(b) For a certain curve $\frac{d^2y}{dx^2} = 6x - 10$. Find the equation of the curve if it passes through the point (1,1) with gradient -1.

4

(c) For the parabola $x^2 = -16y$, find

3

(i) the focal length

(ii) the coordinates of the focus

(iii) the equation of the directrix.



End of half-yearly exam

(1) (a) (i) $-\frac{1}{3x^3} - \frac{1}{2x^2} + c$

(ii) $\frac{9x^5}{5} + 2x^3 + x + c$

(b) (i) $-1\frac{1}{3}$

(ii) $\frac{1}{2}$

(c) Show that LHS = RHS = $9\frac{7}{24}$.

(2)

40	80	120	160	200
12.6	11.9	10.5	10.5	11.6

(a) (i) (α) 2736.0 (β) 2749.3

(ii) 0.2474 ML

(b) (i)

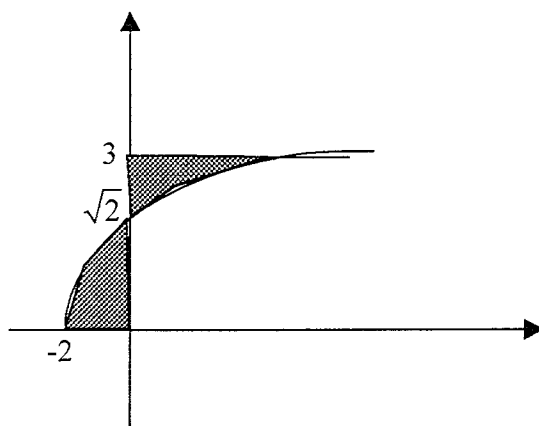

(ii) Proof

(c) $y = 2\sqrt{x^3} - 1$

(3) (a) (i) $18 + \frac{9\pi}{2}$ (ii) -9

(b) $3x - 4y - 9 = 0$ or $3x - 4y + 11 = 0$

(c) (i) $x = -4; y \neq 3$

(ii) $y = 3$ has no gradient.

(d) (i) Proof

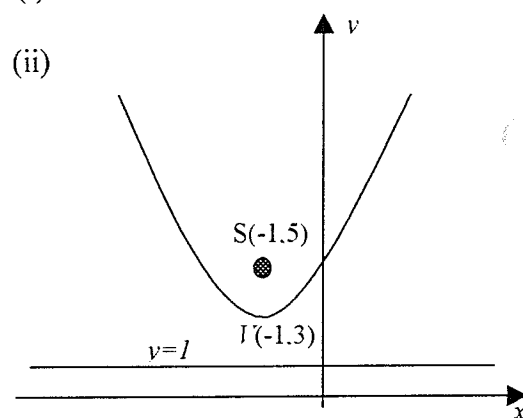

(4) (a) (i) Proof (ii) Proof

(b) Proof, 28 cm^3

(c) $x^2 = 12y$