

Assignment 1 2005

(Total marks: 130)

Question 1

(2)

Simplify the following expressions:

(a) $80a^{12}b^8 \div 16a^3b^6$

(b) $\frac{5e^6f^4}{15ef^2}$

Question 2

(2)

Simplify the following expressions:

(a) $40a^{15}b^8 \div 10a^7b^4$

(b) $\frac{4m^4n^7}{24m^3n^2}$

Question 3

(4)

Simplify each of the following:

(a) $\frac{5x^{11} \times 3x^7}{12x^{15}}$

(b) $\frac{2f^2 \times 6f^7}{4f^2 \times 5f^3}$

Question 4

(2)

Simplify each of the following:

(a) $y^5 \times (y^4)^3$

(b) $10 \times (t^5)^2 \div (t^2)^4$

Question 5

(2)

Simplify:

(a) $(2d)^3$

(b) $(3y)^2$

Question 6

(2)

Simplify:

$\left(\frac{4f^2}{j^4}\right)^3$

Question 7

(4)

Simplify the following expressions:

(a) $(a^3b^5)^4 \times (a^3b^2)^3$

(b) $\frac{(a^2b^4)^4}{(a^2b^3)^3}$

Question 8

(3)

Simplify the following expressions:

(a) $5x^{-3} \times 10x^7$

(b) $(8a^2b^{-2})^2 \div 16a^3b^{-6}$

(3)

Question 9

Simplify the following expressions:

(a) $3x^{-4} \times 5x^7$

(b) $(4a^4b^5)^3 \div 8a^{-3}b^4$

(2)

Question 10

For the following algebraic expressions, simplify where possible and express with positive indices.

(a) $\frac{2}{3a^{-1}}$

(b) $\frac{12}{6q^{-3}}$

(2)

Question 11

Simplify each expression.

(a) $\frac{m^5}{10m^2 \times m^3}$

(b) $\frac{5x^2 \times 5x^8}{15x^{10}} + 6x^0$

(4)

Question 12

Simplify the following expressions (give your answers with positive indices):

(a) $(16a^{10}b^4)^{\frac{1}{2}}$

(b) $\sqrt[3]{p^9q^{-6}}$

(3)

Question 13

Simplify the following.

$\frac{(m^{-1}n^3)^{\frac{1}{3}}}{mn^2} \times \frac{m^{\frac{1}{3}}n^{-1}}{m^{\frac{2}{3}}}$

(5)

Question 14

Simplify the following, expressing the answers with positive indices.

(a) $\frac{r^{-2}s^3}{r^5} \div \frac{r^{-2}s^4}{r^3s^{-5}}$

(b) $\left(\frac{2b^{-3}c^2}{c}\right)^{-3} \times \frac{b^{-3}c^2}{(2b^{-1}c^2)^{-1}}$

Question 15

(1)

Expand the following expression:

$$5x^4(4y + 3x^3)$$

Question 16

(4)

A square has diagonals that are 13 cm long.

(a) By treating the square as a rhombus, find its area.

(b) Calculate the lengths of the sides of the square from the area you found, correct to one decimal place.

Question 17

(4)

A rhombus has one diagonal twice the length of the other diagonal and an area of 56.25 cm^2 . Find the length of each diagonal.

Question 18

(2)

Find (a) the arc length and (b) the perimeter of the sector correct to 1 decimal place.

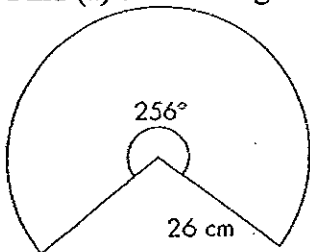

Question 19

(6)

The diagram shows a cone and the curved surface of the cone, opened out. When cut down a slant edge, and opened out, the cone is a sector of a circle.

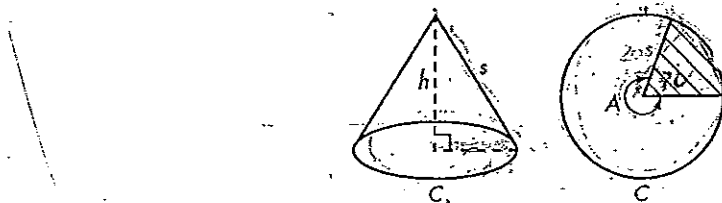

(a) Imagine a cone of slant height 20 cm. What is the circumference of the complete circle needed to make it?

(b) The angle A is 290° for a particular cone. What is the length of the part of the circumference that is used?

(c) What is the radius of the base of the completed cone?

Question 20

(4)

A 70 cm long arc from a circle with a radius of 18 cm is the curved boundary of a sector.

(a) Calculate the angle subtended at the centre of the circle by the arc to the nearest degree.

(b) Find the area of the sector.

(5)

Question 21

The diagram shows an athletics track with two straight sections and semi-circular ends. Lanes are 1 m wide.

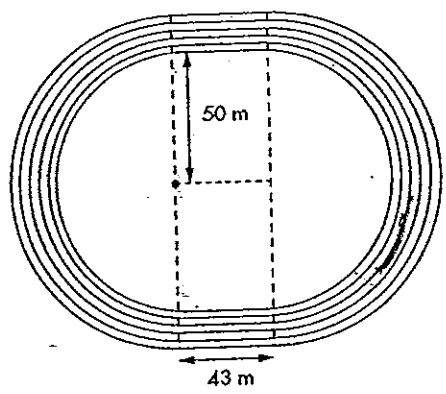

- (a) Find the length of the track on the inside of the third lane from the inside.
- (b) Find the length of the track on the inside of the fifth lane from the inside.
- (c) Find the difference between the length of the third and fifth lanes for a one lap race.

(4)

Question 22

Find the surface area of:

(a)

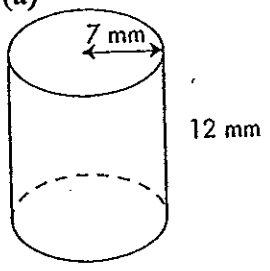

(b)

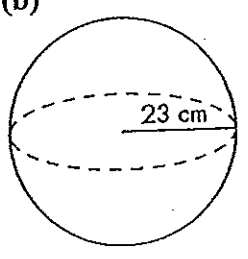

Question 23

What is the surface area of a sphere with a radius quadruple that of a sphere with a surface area of 90 cm²?

(3)

Question 24

Find the surface area of the following shape to two decimal places

(2)

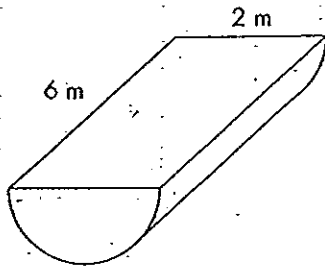

Question 25

(5)

A set of stairs at the front of a building is made up of three steps as shown.

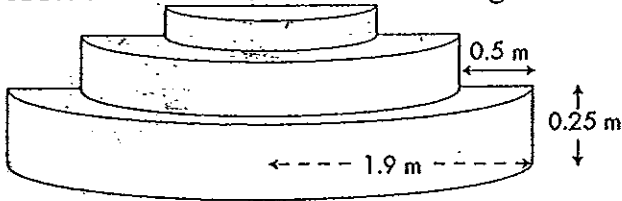

The base of the steps has a radius of 1.9 m and each step has a width of 0.5 m. Each step is 0.25 m higher than the previous one.

Calculate the cost, to two decimal places, of pebblecreting the stairs if it costs \$34 per m^2 .

When you look down the stairs the top of all 3 stairs look like a semicircle.

Question 26

(2)

Find the volume of the following solid:

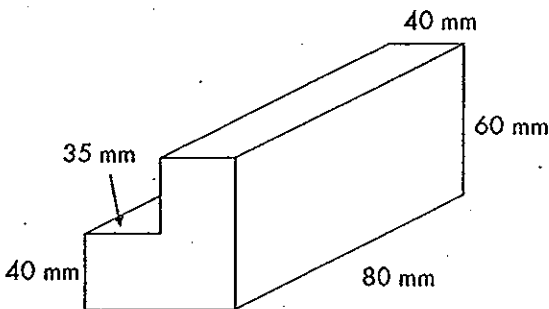

Question 27

(2)

What is the volume of a cylinder which is 30 cm in diameter and 40 cm long? (Answer to the nearest thousand cm^3 .)

Question 28

In this question you are to investigate whether the volumes of 5 cent and 20 cent coins are related to (4) their value.

Information: The 5 cent coin has a diameter of 19 mm, and a thickness of 1.1 mm. The 20 cent coin has a diameter of 28 mm, and a thickness of 2.0 mm.

- Find the area of the top of each coin.
- Find the volume of each coin.
- Divide the volumes by the values to get measures of 'volume per cent'.
- Interpret the results.

(3)

Question 29

Find the volume of the following solid:

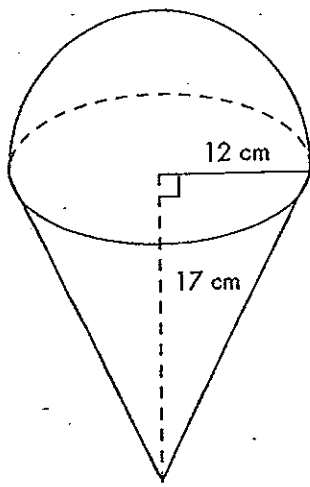

(3)

Question 30

What is the volume of a sphere with a radius double that of a sphere with a volume of 29 mm^3 ?

(4)

Question 31

An artist has painted a picture. She pays \$120 to have it framed. She puts it into an exhibition at a gallery in the hope of selling it. If it sells, the gallery takes 25% of the selling price as commission. The artist wants to make \$1200 profit on the painting, to pay for her time and creative talent.

- (a) How much money does she need to get from the gallery?
- (b) What is the price at which she wants her painting to sell?

(1)

Question 32

Calculate the percentage commission, correct to one decimal place, paid if \$2900 is earned on sales totalling \$62 000.

(3)

Question 33

<u>Taxable income</u>	<u>Tax on this income</u>
\$1 – \$6000	Nil
\$6001 – \$21 600	17 cents for each \$1 over \$6000
\$21 601 – \$52 000	\$2652 + 30 cents for each \$1 over \$21 600
\$52 001 – \$62 500	\$11 772 + 42 cents for each \$1 over \$52 000
\$62 501 and above	\$16 182 + 47 cents for each \$1 over \$62 500

George is paid fortnightly. In a particular fortnight he grosses \$1578.50. How much should his employer deduct for income tax, given there are 26.07 fortnights per year?

(2)

Question 34

A term deposit earns \$580.00 by being placed at 8% for 3 months. What amount was deposited?

(2)

Question 35

A term deposit of \$64 000 earns \$2720 by being deposited at a certain interest rate for 6 months. What is the interest rate?

Question 36 (2)
Find R if:
(a) $I = \$1431$, $P = \$6750$, $T = 4$ years
(b) $I = \$7154.77$, $P = \$28\ 600$,
 $T = 6$ years 7 months

Question 37 (2)
Toula invests \$2000 at a simple interest rate of 5% per annum. How many years will it take for Toula to double her investment?

Question 38 (2)
Using the compound interest formula calculate the total amount owing on a loan of \$7600 after four years, if the 11% interest p.a. is compounded annually.

Question 39 (4)
How much interest is added over six years to an account paying 9% interest on an initial sum of \$42 000 if the interest is compounded quarterly?

Question 40 (4)
How much more will an investor get on an investment of \$24 000 over 5 years in an account offering 7.5% p.a. if the interest is compounded monthly rather than annually?

Question 41 (4)
Sales of \$32 500 grow to \$73 200 in 12 years. Calculate the percentage growth p.a.

Question 42 (3)
Andre deposits \$6000 towards the cost of a round the world trip he plans to take in 6 years time. Find the interest earned if it is calculated at:
(a) 6.8% simple interest
(b) 6.8% compounded annually
(c) 6.8% compounded quarterly

Question 43 (3)
Find the total amount of interest charged over the first three repayment periods for a loan of \$98 500 at 7.1% compounded monthly, with a monthly repayment of \$710.

Answers - Jr 9 Assignment 1 2005

Qu 1 (a) $5a^9b^2$ (b) $\frac{1}{3}e^5f^2$

Qu 2 (a) $4a^8b^4$ (b) $\frac{1}{6}mn^5$

Qu 3 (a) $\frac{5x^3}{4}$ (b) $\frac{3f^4}{5}$

Qu 4 (a) y^{17} (b) $10t^2$

Qu 5 (a) $8d^3$ (b) $9y^2$

Qu 6 (a) $\frac{64f^6}{j^{12}}$

Qu 7 (a) $a^{21}b^{26}$ (b) a^2b^7

Qu 8 (a) $50x^4$ (b) $4ab^2$

Qu 9 (a) $15x^3$ (b) $8a^{15}b^{11}$

Qu 10 (a) $\frac{2a}{3}$ (b) $2q^3$

Qu 11 (a) $\frac{1}{10}$ (b) $7\frac{2}{3}$

Qu 12 (a) $4a^5b^2$ (b) $P\frac{3}{q^2}$

Qu 13 (a) $m^{-1}n^{-8/3}$

Qu 14 (a) $\frac{1}{r^2s^6}$ (b) $\frac{1}{4}b^5c$

Qu 15 (a) $20x^4y + 15x^7$

Qu 16 (a) $A = 84.5 \text{ cm}^2$ (b) $x = \sqrt{84.5} = 9.2 \text{ cm}$

Qu 17 sides are 37.5 cm

Qu 18 (a) 116.2 (b) 168.2

Qu 19 (a) 125.7 (b) 101.23 (c) 16.1 cm

Qu 20 (a) 223° (b) 630 cm^2

Qu 21 (a) 412.7 (b) 425.3 (c) 12.6 m

Qu 22 (a) 835.7 mm^2 (b) 6647.6 cm^3

Qu 23 1440 cm^2

Qu 24 34.0 m^2

Qu 25 12.27 m^2

Qu 26 304000

Qu 27 ≈ 28000

Qu 28 (a) $54 = 227.53$ (b) $54 = 311.58 \text{ mm}^3$
 $204 = 615.75$ $204 = 1231.5 \text{ mm}^3$

(c) $54 = 62.38 \text{ mm}^3/\text{cut}$ $204 = 61.57 \text{ mm}^3$
 (d) Yes Volumes are related to value.

Qu 29 $3619.1 + 2563.5 = 6182.6 \text{ cm}^3$

Qu 30 232 mm^3

Qu 31 (a) $\$1320$ (b) $\$1760$

Qu 32 4.7%

Qu 33 $\$8517.30 \text{ p.a.} + \text{tax} = \$326.71 \text{ per fortnight.}$

Qu 34 $\$29000$

Qu 35 8.5%

Qu 36 (a) 5.3% (b) 3.8%

Qu 37 $n = 20 \text{ yrs.}$

Qu 38 $\$11537.34$

Qu 39 $\$28438.20$

Qu 40 $\$34879.07 - \$34455.10 = \$423.97$

Qu 41 $10.44\% \text{ p.a.}$

Qu 42 (a) $\$2448$ (b) $\$2903.87$ (c) $\$2991.95$

Qu 43 $M_1: \$582.79$
 $M_2: \$582.07$
 $M_3: \$581.31$ } Total $\$1746.17$

Answers - yr 9 Assignment 1 2005

Qu 1 (a) $5a^9b^2$ (b) $\frac{1}{3}e^5f^2$

Qu 2 (a) $4a^8b^4$ (b) $\frac{1}{6}mn^5$

Qu 3 (a) $\frac{5x^3}{4}$ (b) $\frac{3f^4}{5}$

Qu 4 (a) y^{17} (b) $10t^2$

Qu 5 (a) $8d^3$ (b) $9y^2$

Qu 6 (a) $\frac{64f^6}{j^{12}}$

Qu 7 (a) $a^{21}b^{26}$ (b) a^2b^7

Qu 8 (a) $50x^4$ (b) $4ab^2$

Qu 9 (a) $15x^3$ (b) $8a^{15}b^{11}$

Qu 10 (a) $\frac{2a}{3}$ (b) $2q^3$

Qu 11 (a) $\frac{1}{10}$ (b) $7\frac{2}{3}$

Qu 12 (a) $4a^5b^2$ (b) $p\frac{3}{q^2}$

Qu 13 (a) $m^{-1}n^{-8/3}$

Qu 14 (a) $\frac{1}{r^2s^6}$ (b) $\frac{1}{4}b^5c$

Qu 15 (a) $20x^4y + 15x^7$

Qu 16 (a) $A = 84.5 \text{ cm}^2$ (b) $x = \sqrt{84.5} = 9.2 \text{ cm}$

Qu 17 sides are 37.5 cm

Qu 18 (a) 116.2 (b) 158.2

Qu 19 (a) 125.7 (b) 101.23 (c) 16.1 cm

Qu 20 (a) 223° (b) 630 cm^2

Qu 21 (a) 1412.7 (b) 425.3 (c) 12.6 m

Qu 22 (a) 835.7 mm^2 (b) 6647.6 cm^3

Qu 23 1440 cm^2

Qu 24 34.0 m^2

Qu 25 12.27 m^2

Qu 26 304000

Qu 27 ≈ 28000

Qu 28 (a) $5d = 287.53$ (b) $5d = 311.58 \text{ mm}^3$
 $20d = 615.75$ $20d = 1231.5 \text{ mm}^3$

(c) $5d = 62.38 \text{ mm}^3/\text{cent}$ $20d = 61.57 \text{ mm}^3$
 (d) Yes Volumes are related to value.

Qu 29 $3619.1 + 2563.5 = 6182.6 \text{ cm}^3$

Qu 30 232 mm^3

Qu 31 (a) $\$1320$ (b) $\$1760$

Qu 32 4.7%

Qu 33 $\$8517.30 \text{ p.a.} + \text{tax} = \$326.71 \text{ p.a. for night.}$

Qu 34 $\$29000$

Qu 35 8.5%

Qu 36 (a) 5.3% (b) 3.8%

Qu 37 $n = 20 \text{ yrs.}$

Qu 38 $\$11537.34$

Qu 39 $\$28438.20$

Qu 40 $\$34879.07 - \$34455.10 = \$423.97$

Qu 41 $10.44\% \text{ p.a.}$

Qu 42 (a) $\$2448$ (b) $\$2903.87$ (c) $\$2991.95$

Qu 43 $M_1: \$582.79$
 $M_2: \$582.07$
 $M_3: \$581.31$ } Total $\$1746.17$

Answers - yr 9 Assignment 1 2005

Qu 1 (a) $5a^9b^2$ (b) $\frac{1}{3}e^5f^2$

Qu 2 (a) $4a^8b^4$ (b) $\frac{1}{6}mn^5$

Qu 3 (a) $\frac{5x^3}{4}$ (b) $\frac{3f^4}{5}$

Qu 4 (a) y^{17} (b) $10x^{12}$

Qu 5 (a) $8d^3$ (b) $9y^2$

Qu 6 (a) $\frac{64f^6}{j^{12}}$

Qu 7 (a) $a^{21}b^{26}$ (b) a^2b^7

Qu 8 (a) $50x^4$ (b) $4ab^2$

Qu 9 (a) $15x^3$ (b) $8a^{15}b^{11}$

Qu 10 (a) $\frac{2a}{3}$ (b) $2q^3$

Qu 11 (a) $\frac{1}{10}$ (b) $7\frac{2}{3}$

Qu 12 (a) $4a^5b^2$ (b) $p\frac{3}{q^2}$

Qu 13 (a) $m^{-1}n^{-8/3}$

Qu 14 (a) $\frac{1}{r^2s^6}$ (b) $\frac{1}{4}b^5c$

Qu 15 (a) $20x^4y + 15x^7$

Qu 16 (a) $A = 84.5 \text{ cm}^2$ (b) $x = \sqrt{84.5} = 9.2 \text{ cm}$

Qu 17 sides are 37.5 cm

Qu 18 (a) 116.2 (b) 158.2

Qu 19 (a) 125.7 (b) 101.23 (c) 16.1 cm

Qu 20 (a) 223° (b) 630 cm^2

Qu 21 (a) 1412.7 (b) 425.3 (c) 12.6 m

Qu 22 (a) 835.7 mm^2 (b) 6647.6 cm^3

Qu 23 1440 cm^2

Qu 24 34.0 m^2

Qu 25 12.27 m^2

Qu 26 304000

Qu 27 ≈ 28000

Qu 28 (a) $5d = 287.53$ (b) $5d = 311.58 \text{ mm}^3$
 $20d = 615.75$ $20d = 1231.5 \text{ mm}^3$

(c) $5d = 62.38 \text{ mm}^3/\text{cent}$ $20d = 61.57 \text{ mm}^3$
 (d) Yes Volumes are related to value.

Qu 29 $3619.1 + 2563.5 = 6182.6 \text{ cm}^3$

Qu 30 232 mm^3

Qu 31 (a) $\$1320$ (b) $\$1760$

Qu 32 4.7%

Qu 33 $\$8517.30$ per cent tax = $\$326.71$ per fortnight.

Qu 34 $\$29000$

Qu 35 8.5%

Qu 36 (a) 5.3% (b) 3.8%

Qu 37 $n = 20 \text{ yrs.}$

Qu 38 $\$11537.34$

Qu 39 $\$28438.20$

Qu 40 $\$34879.07 - \$34455.10 = \$423.97$

Qu 41 $10.44\% \text{ p.a.}$

Qu 42 (a) $\$2448$ (b) $\$2903.87$ (c) $\$2991.95$

Qu 43 $M_1: \$582.79$
 $M_2: \$582.07$
 $M_3: \$581.31$ } Total $\$1746.17$

Answers - Jr 9 Assignment 1 2005

Qu 1 (a) $5a^9b^2$ (b) $\frac{1}{3}e^5f^2$

Qu 2 (a) $4a^8b^4$ (b) $\frac{1}{6}mn^5$

Qu 3 (a) $\frac{5x^3}{4}$ (b) $\frac{3f^4}{5}$

Qu 4 (a) y^{17} (b) $10t^2$

Qu 5 (a) $8d^3$ (b) $9y^2$

Qu 6 (a) $\frac{64p^6}{j^{12}}$

Qu 7 (a) $a^{21}b^{26}$ (b) a^2b^7

Qu 8 (a) $50x^4$ (b) $4ab^2$

Qu 9 (a) $15x^3$ (b) $8a^{15}b^{11}$

Qu 10 (a) $\frac{2a}{3}$ (b) $2q^3$

Qu 11 (a) $\frac{1}{10}$ (b) $7\frac{2}{3}$

Qu 12 (a) $4a^5b^2$ (b) p^3/q^2

Qu 13 (a) $m^{-1}n^{-8/3}$

Qu 14 (a) $\frac{1}{r^2}S^6$ (b) $\frac{1}{4}b^5c$

Qu 15 (a) $20x^4y + 15x^7$

Qu 16 (a) $A = 84.5 \text{ cm}^2$ (b) $x = \sqrt[3]{84.5} = 9.2 \text{ cm}$

Qu 17 sides are 37.5 cm

Qu 18 (a) 116.2 (b) 158.2

Qu 19 (a) 125.7 (b) 101.23 (c) 16.1 cm

Qu 20 (a) 223° (b) 630 cm^2

Qu 21 (a) 1412.7 (b) 425.3 (c) 12.6 m

Qu 22 (a) 835.7 mm^2 (b) 6647.6 cm^3

Qu 23 1440 cm^2

Qu 24 34.0 m^2

Qu 25 12.27 m^2

Qu 26 304000

Qu 27 ≈ 28000

Qu 28 (a) $5d = 287.53$ (b) $5d = 311.88 \text{ mm}^3$
 $20d = 615.75$ $20d = 1231.5 \text{ mm}^3$

(c) $5d = 62.38 \text{ mm}^3/\text{cent}$ $20d = 61.57 \text{ mm}^3$
(d) Yes Volumes are related to value.

Qu 29 $3619.1 + 2563.5 = 6182.6 \text{ cm}^3$

Qu 30 232 mm^3

Qu 31 (a) $\$1320$ (b) $\$1760$

Qu 32 4.7%

Qu 33 $\$8517.30 \text{ p.a.} + \text{tax} = \$326.71 \text{ per fortnight.}$

Qu 34 $\$29000$

Qu 35 8.5%

Qu 36 (a) 5.3% (b) 3.8%

Qu 37 $n = 20 \text{ yrs.}$

Qu 38 $\$11537.34$

Qu 39 $\$28438.20$

Qu 40 $\$34879.07 - \$34455.10 = \$423.97$

Qu 41 $10.44\% \text{ p.a.}$

Qu 42 (a) $\$2448$ (b) $\$2903.87$ (c) $\$2991.95$

Qu 43 $M_1: \$582.79$
 $M_2: \$582.07$
 $M_3: \$581.31$ } Total $\$1746.17$