

# AUSTRALIAN MATHEMATICS COMPETITION

AN ACTIVITY OF THE AUSTRALIAN MATHEMATICS TRUST

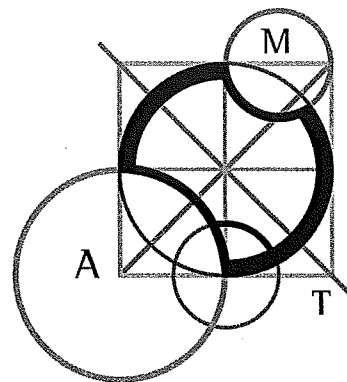

THURSDAY 31 JULY 2008

## JUNIOR DIVISION COMPETITION PAPER

AUSTRALIAN SCHOOL YEARS 7 AND 8  
TIME ALLOWED: 75 MINUTES

### INSTRUCTIONS AND INFORMATION

#### GENERAL

1. Do not open the booklet until told to do so by your teacher.
2. NO calculators, slide rules, log tables, maths stencils, mobile phones or other calculating aids are permitted. Scribbling paper, graph paper, ruler and compasses are permitted, but are not essential.
3. Diagrams are NOT drawn to scale. They are intended only as aids.
4. There are 25 multiple-choice questions, each with 5 possible answers given and 5 questions that require a whole number between 0 and 999. The questions generally get harder as you work through the paper. There is no penalty for an incorrect response.
5. This is a competition not a test; do not expect to answer all questions. You are only competing against your own year in your own State or Region so different years doing the same paper are not compared.
6. Read the instructions on the **Answer Sheet** carefully. Ensure your name, school name and school year are filled in. It is your responsibility that the Answer Sheet is correctly coded.
7. When your teacher gives the signal, begin working on the problems.

#### THE ANSWER SHEET

1. Use only lead pencil.
2. Record your answers on the reverse of the Answer Sheet (not on the question paper) by FULLY colouring the circle matching your answer.
3. Your Answer Sheet will be read by a machine. The machine will see all markings even if they are in the wrong places, so please be careful not to doodle or write anything extra on the Answer Sheet. If you want to change an answer or remove any marks, use a plastic eraser and be sure to remove all marks and smudges.

#### INTEGRITY OF THE COMPETITION

The AMC reserves the right to re-examine students before deciding whether to grant official status to their score.

---

## Junior Division

---

### Questions 1 to 10, 3 marks each

1. The value of  $2008 + 8002$  is

- (A) 1010      (B) 4004      (C) 10008      (D) 8910      (E) 10010
- 

2. Which of the following numbers has the largest value?

- (A) 2.15      (B) 2.2      (C) 2.08      (D) 2.1      (E) 2.185
- 

3. The perimeter of the figure, in centimetres, is

- (A) 8      (B) 10      (C) 12  
(D) 16      (E) 20

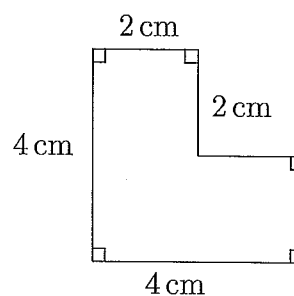

4. One half of  $199\frac{1}{2}$  is

- (A)  $95\frac{1}{2}$       (B)  $95\frac{3}{4}$       (C)  $99\frac{1}{4}$       (D)  $99\frac{1}{2}$       (E)  $99\frac{3}{4}$
- 

5. The value of  $x$  is

- (A) 135      (B) 95      (C) 35  
(D) 55      (E) 45



6. The value of  $\frac{200 \times 8}{200 \div 8}$  is

- (A) 1      (B) 8      (C) 16      (D) 64      (E) 200
- 

7. How many squares of any size are there in the diagram?

- (A) 9      (B) 11      (C) 12  
(D) 14      (E) 16

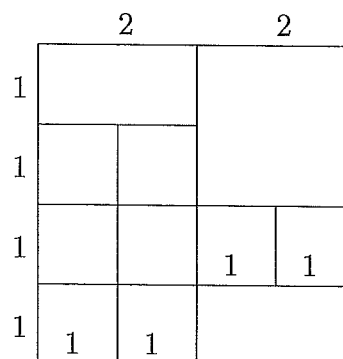

8. A train left Fassifern at 8:58 am and arrived at Broadmeadow at 9:34 am on the same day. The time taken, in minutes, was

- (A) 82                      (B) 22                      (C) 36                      (D) 38                      (E) 78

9. The digits 5, 6, 7, 8 and 9 can be arranged to form even five-digit numbers. The tens digit in the largest of these numbers is

- (A) 5                      (B) 6                      (C) 7                      (D) 8                      (E) 9

10.  $PQRS$  is a square and points  $E$  and  $F$  are outside the square so that  $PQE$  and  $QRF$  are equilateral triangles. The size of  $\angle EQF$ , in degrees, is

- (A) 60                      (B) 90                      (C) 120                      (D) 150                      (E) 180

**Questions 11 to 20, 4 marks each**

11. A rectangle has an area of 72 square centimetres and the length is twice the width. The perimeter, in centimetres, of the rectangle is

- (A) 34                      (B) 36                      (C) 42                      (D) 48                      (E) 54

12. Marbles of three different colours are in a tin and  $\frac{2}{5}$  of the marbles are red,  $\frac{1}{3}$  are green and the remaining 12 are yellow. The number of marbles in the tin is

- (A) 30                      (B) 45                      (C) 54                      (D) 60                      (E) 90

13. In the diagram, triangles  $PQR$  and  $LMN$  are both equilateral and  $\angle QSM = 20^\circ$ . What is the value of  $x$ ?

- (A) 70                      (B) 80                      (C) 90  
(D) 100                      (E) 110

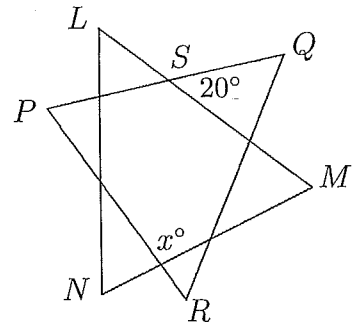

14. At half-time in a soccer match between Newcastle and Melbourne, the score was Newcastle 1, Melbourne 0. Three goals were scored in the second half. Which of the following could **not** be the result of the match?
- (A) The match was drawn  
 (B) Newcastle won by 2 goals  
 (C) Melbourne won by 2 goals  
 (D) Newcastle won by 1 goal  
 (E) Newcastle won by 4 goals

15. In how many ways can 12 be written as the sum of two or more different positive whole numbers? (Changing the order of addition does not count as a different way.)
- (A) 12                      (B) 13                      (C) 14                      (D) 15                      (E) 16

16. How many different positive numbers are equal to the product of two odd one-digit numbers?
- (A) 25                      (B) 15                      (C) 14                      (D) 13                      (E) 11

17. The perimeter of this rectangular paddock is 700 m. It is subdivided into six identical paddocks as shown.

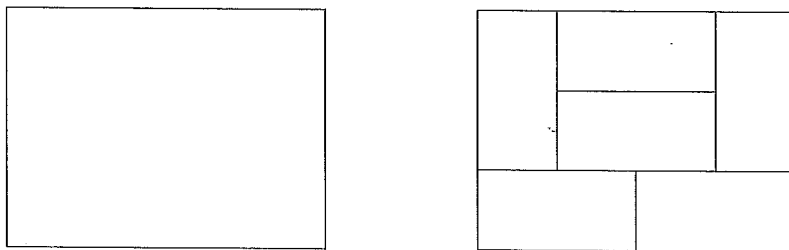

The perimeter, in metres, of each of the six smaller paddocks is

- (A)  $116\frac{1}{3}$                       (B) 300                      (C) 200                      (D) 150                      (E) 600

18. The student lockers at Euler High School are to be numbered consecutively from 1 to 500 using plastic digits which cost 5 cents each. The total cost of all the digits will be
- (A) \$25                      (B) \$63.65                      (C) \$69.50                      (D) \$69.60                      (E) \$85

19. In the grid below, the squares are to be filled with the numbers 1, 2, 3 and 4 so that they appear once only in each row, each column and each diagonal.

1			
	2		
		3	X
			Y

The largest possible value of  $X + Y$  is

- (A) 4                      (B) 5                      (C) 6                      (D) 7                      (E) 8

20. The average of one group of numbers is 4. A second group contains twice as many numbers and has an average of 10. The average of both groups of numbers combined is

- (A) 5                      (B) 6                      (C) 7                      (D) 8                      (E) 9

**Questions 21 to 25, 5 marks each**

21. A cube with edge length 2 metres is cut up into cubes each with edge length 5 centimetres. If all these cubes were stacked one on top of the other to form a tower, the height of the tower would be

- (A) 32 km              (B) 160 m              (C) 1600 m              (D) 3.2 km              (E) 320 m

22. A number is less than 2008. It is odd, it leaves a remainder of 2 when divided by 3 and a remainder of 4 when divided by 5. What is the sum of the digits of the largest such number?

- (A) 26                      (B) 25                      (C) 24                      (D) 23                      (E) 22

23. Farmer Taylor of Burra has two tanks. Water from the roof of his farmhouse is collected in a 100 kL tank and water from the roof of his barn is collected in a 25 kL tank. The collecting area of his farmhouse roof is 200 square metres while that of his barn is 80 square metres. Currently, there are 35 kL in the farmhouse tank and 13 kL in the barn tank.

Rain is forecast and he wants to collect as much water as possible. He should:

- (A) empty the barn tank into the farmhouse tank  
 (B) fill the barn tank from the farmhouse tank  
 (C) pump 10 kL from the farmhouse tank into the barn tank  
 (D) pump 10 kL from the barn tank into the farmhouse tank  
 (E) do nothing

24. A fishtank with base 100 cm by 200 cm and depth 100 cm contains water to a depth of 50 cm. A solid metal rectangular prism with dimensions 80 cm by 100 cm by 60 cm is then submerged in the tank with an 80 cm by 100 cm face on the bottom.

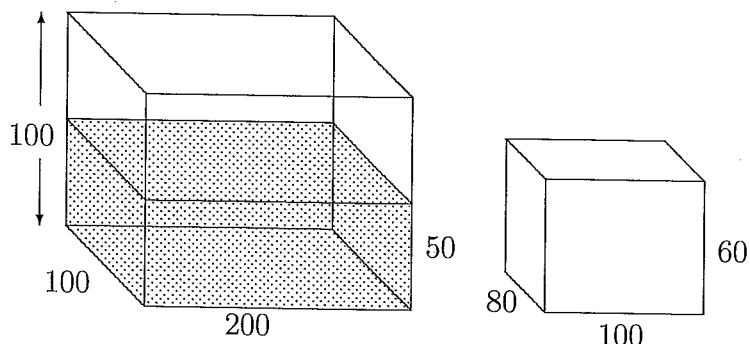

The depth of water, in centimetres, above the prism is then

- (A) 12                      (B) 14                      (C) 16                      (D) 18                      (E) 20
- 
25. A strip of paper is folded in a line at an angle  $x^\circ$  to the sides and then folded underneath forming an angle of  $20^\circ$  as shown.

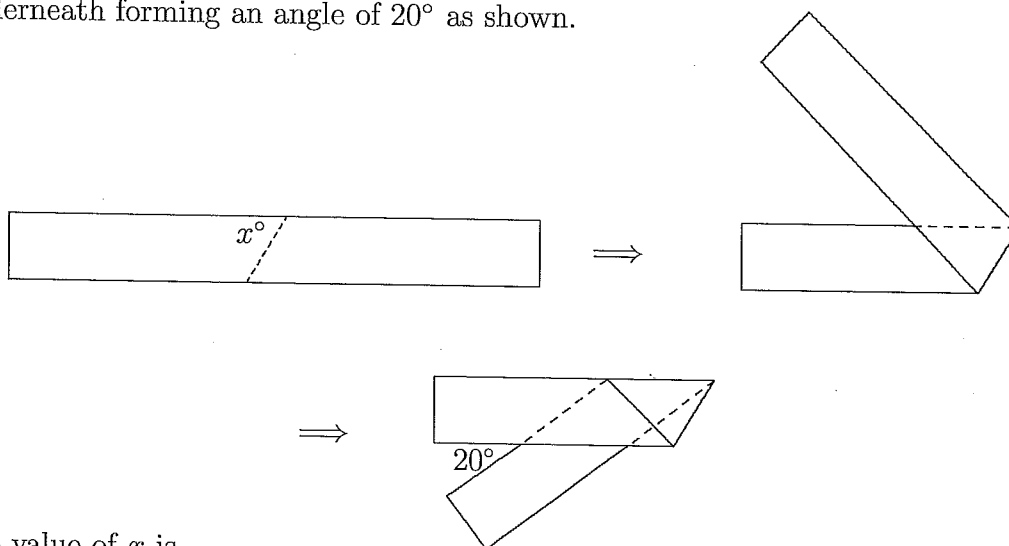

The value of  $x$  is

- (A) 60                      (B) 65                      (C) 70                      (D) 75                      (E) 80
- 

For questions 26 to 30, shade the answer as an integer from 0 to 999 in the space provided on the answer sheet.

Question 26 is 6 marks, question 27 is 7 marks, question 28 is 8 marks, question 29 is 9 marks and question 30 is 10 marks.

---

26. A two-digit number  $ab$  and its reversal  $ba$  are both prime. For example, 13 and 31 are both prime. What is the largest possible sum of these two numbers  $ab$  and  $ba$ ?
-

27. Given a regular heptagon (7-sided polygon), how many obtuse-angled triangles are there, where the vertices of each triangle are vertices of the heptagon?

28. A rectangular prism 6 cm by 3 cm by 3 cm is made up by stacking 1 cm by 1 cm by 1 cm cubes. How many rectangular prisms, including cubes, are there whose vertices are vertices of the cubes, and whose edges are parallel to the edges of the original rectangular prism? (Rectangular prisms with the same dimensions but in different positions are different.)

29. Let us call a sum of integers *cool* if the first and last terms are 1 and each term differs from its neighbours by at most 1. For example, the sum  $1 + 2 + 3 + 4 + 3 + 2 + 3 + 3 + 3 + 2 + 3 + 3 + 2 + 1$  is cool. How many terms does it take to write 2008 as a cool sum if we use no more terms than necessary?

30. A monument has been constructed from identical stone cubes. The views from above, the front *f* and the side *s* are shown.

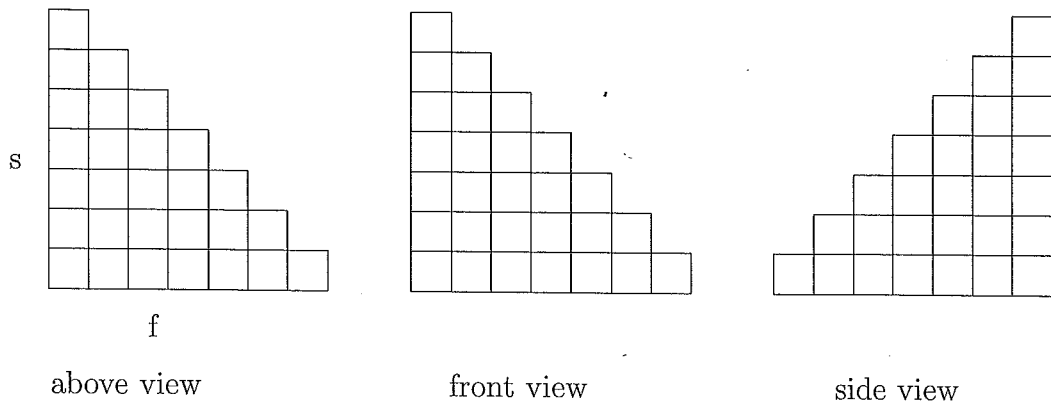

What is the largest number of stones in the monument consistent with these views?