

Paper to UDT 2019 (The extended abstract)

The Swedish next generation Light Weight Torpedo (LWT) system – "Torpedsystem 47" (TS47)

Update on the development of TS47, which is developed and optimized for ASW in extreme littoral waters with high sea traffic intensity

1 Introduction

The new Swedish LWT is the fifth generation LWT since the early 1960:s to be developed and operated according to the requirements from the Swedish Armed Forces (SwAF). Like it's predecessors, the new generation of LWT is being developed and produced by the Swedish defence company Saab under a contract from the Swedish Defence Materiel Administration (FMV).

This close cooperation between industry, authorities, end-users as well as academia has been a key to overcome the challenges of ASW in extreme littoral waters with high sea traffic intensity.

The underwater environmental conditions in the Swedish operational area, the Baltic Sea and eastern part of the North Sea, provide significant challenges to overcome in order to develop an efficient torpedo system. The Baltic Sea is to most the extent a shallow sea that features large variations in topography, sea floor material and vast areas of archipelago along the Swedish and Finnish coast.

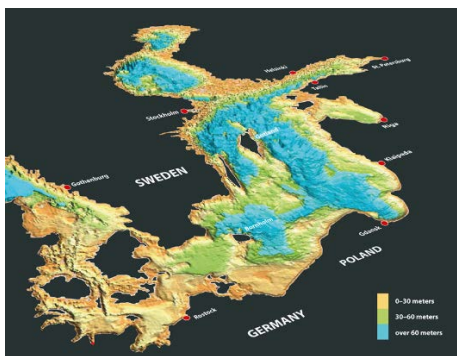

Fig 1. Underwater topography of the Baltic Sea

Furthermore, the brackish water in the Baltic Sea has a great impact on vehicle buoyancy and common occurrence of haloclines in addition to thermoclines. As for the eastern part of the North Sea, the challenges are more comparable with those found in the Atlantic.

These environmental conditions combined with the high sea traffic intensity require special adaptations in terms of navigational systems, active and passive sensor systems and communication systems.

2 Design principles

Torpedsystem 47 (TS47) is primarily designed for ASW but with capability to be used in ASuW. It can be launched from Surface Vessels, Submarines and Helicopters. Important key functionalities for TS47 to meet the Baltic Sea conditions are: low speed capability, communication capability and an ability to function in complex scenarios as well as in shallow or deep waters.

In order to reduce technical risks, and thereby staying within the allowed budget for the project, a design to cost model was chosen which includes an evolutionary development plan for the torpedo system. As a result TS47 is based on a modular design and the use of COTS components where applicable.

One of the key design features of the TP47 is the modular design. Not only does it add value when using and maintaining the system, but it also enables cost efficient upgrades and evolutionary development to incorporate new technologies and adding system functions. It also enables the use of an advanced exercise module replacing the warhead module in the torpedo, thus eliminating the need for a separate training vehicle. After the exercise shot, the exercise module inflates its balloon so that you can recover the torpedo from the surface.

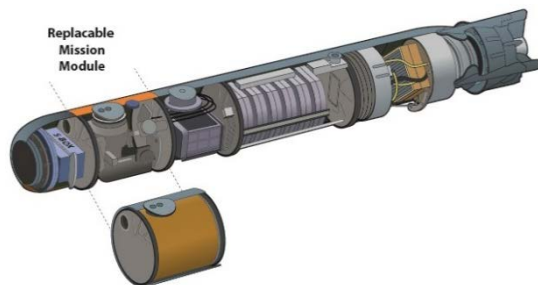

Fig 2. Torped 47 is designed so that you only need change one module to change between the warhead- and exercise version, otherwise it is the same torpedo.

As a result, training of SwAF in ASW scenarios is cost-efficient and highly accessible, granting frequent and qualified training as well as strategy development.

3 Innovation/Technical Topics

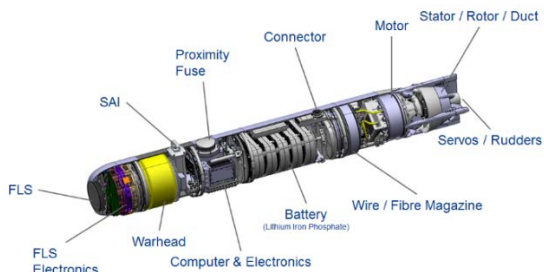

Fig 3. Technical overview Torpedo 47

Torped 47 is designed based on the experience from today's torped 45(LWT), torped 62(HWT) and AUV62-AT.

The Homing system for Torped 47 utilizes the next generation of a Swedish built forward-looking sonar and is optimized for Baltic sea conditions with the capability to function in blue water. It has the capability to operate in both passive and active homing that have high resistance to reverberation and false targets.

With a new electrical propulsion system and a pump-jet, Torped 47 will get better dynamic control characteristics with a wider speed envelope, ensuring good maneuverability and low signature.

Endurance will increase with a new battery type (LiFePO4) that also fulfills all system safety requirements to be used on both submarines, surface ships and helicopters.

Torped 47 will also be IM-tested as a complete torpedo (with both a warhead and battery)

4 Status in development

Development of TS47 is now in an intense testing phase with the second prototype, R2. R2 is built almost like a serially produced torpedo 47 with an exercise module. Testing is planned to be conducted both as “stand alone” and from SwAF platforms during 2019.



Fig 4. Testing at Saab test facility outside Motala

To maintain high pace in the development Model Based Definition(MBD) has been an important tool to make the design changes between the different prototypes smooth and easy.

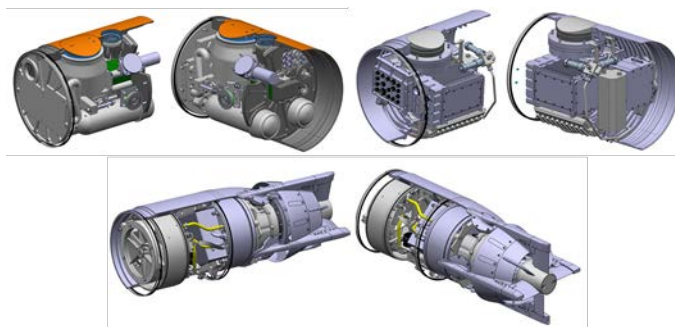

Fig 5. Parts from Torpedo 47 in MBD-view

In January 2018 the Finnish Defence Forces decided to order TS 47 for the Hamina class upgrade and the Squadron 2020 project.

According to current plans, TS47 will be operational in the Swedish Armed Forces from 2022/2023 and will provide a reliable and highly adaptable underwater weapon to meet current and future requirements and challenges.

References

<http://www.fmv.se/en/Projects/New-lightweight-torpedo-system/>

Author/Speaker Biographies

Lt(N) **Magnus Lind** is the Project Manager for Project NLT(TS47) at FMV, SWEDEN

Magnus has been working as Project manager for NLT since 2013. In addition to his role as project manager, Magnus has worked as an expert regarding testing of ASW systems for the SwAF.

Magnus has a background as PWO(UW) in SwAF, where he served on different types of surface ships. During trials for FS Visby-class he was deeply engaged in making the Visby- class operative for ASW actions.