

Testing BMS with real-time simulation.

Discover our cutting-edge, precise, and versatile simulation solutions for battery management systems.



OPAL-RT
TECHNOLOGIES

opal-rt.com

Where flexibility meets performance.

This BMS hardware-in-the-loop (HIL) test solution combines our real-time simulation capabilities with high-precision battery cell emulators to enable comprehensive, flexible, and safe testing of BMS hardware and software.

SOLUTION HIGHLIGHTS

Our platform is designed to help developers test BMS functionality under a wide range of operating conditions, reduce reliance on physical battery packs, and improve test coverage in a controlled, repeatable environment, with the objective of complying with standards such as ISO 26262.

The OPAL-RT solution supports:

01

Fault injection features such as open circuit, short circuit, and polarity reversal.

02

Test sequencing to perform charge and discharge cycles, as well as cell balancing.

03

Expansion to include PHIL and cell monitoring device emulation (CMDE).

04

Real-time simulation of battery behavior, power electronics, and vehicle dynamics.

05

Support of industry standard BMS chipsets and communication protocols such as CAN.

06

Emulation of individual battery cells with programmable voltages, currents, and temperatures allowing for testing out-of-range conditions.

07

Coverage of test cases at the cell, module, and pack levels.



Contact us
to speak to
a sales rep

Cell monitoring device emulation (CMDE)

OPAL-RT has developed the Cell Monitoring Device Emulation (CMDE) add-on for NI VeriStand, our own FPGA-based virtualization technology for BMS cell monitoring devices from major brands such as Analog Devices, Inc. (ADI).

Key benefits

01

Expanded test coverage and faulting capabilities on the virtualized cell monitoring devices, like temperature faults, open wires, broken communication links, or CRC errors.

02

Reduced time, cost, and complexity of setting up hundreds of redundant physical cell emulators by virtualizing integrated circuits, while still maintaining communication link.

03

Maintained integrity of the SPI daisy-chain communication, allowing for connection to real Cell Monitoring Devices as well as physical cell emulators.

VIRTUALIZING BMS SLAVES

The virtualization of BMS slave with OPAL-RT's Cell Monitoring Device Emulation (CMDE) add-on removes the need of redundant cell emulation with multiple Battery Cells Simulators (BCS).

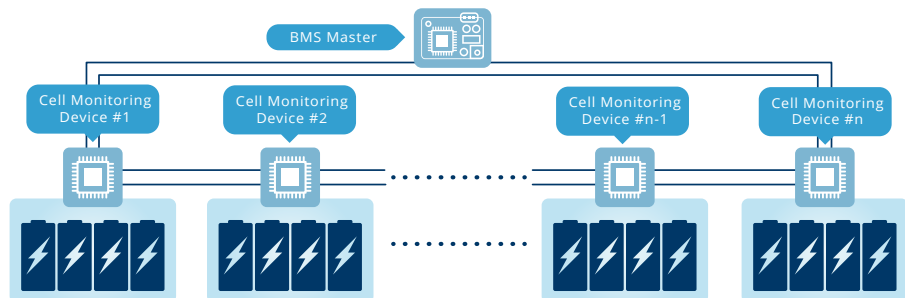

BMS testbench customers

RIVIAN

ARAI
Progress through Research

Sandia National Laboratories

automotive engineering **iaU**

TATA

Battery cell simulator (BCS)

The comemso® BCS is a flexible high-precision bi-directional voltage and current source that enable OPAL-RT HIL to perform BMS HIL testing

Compact BCS options overview							
PRODUCT VARIANT	LIGHT	LIGHT +F	BASIC	BASIC +F	BASIC +F+µA	BASIC +F+ HILOAD	FULL
Height	2 HU	2 HU	2 HU	2 HU	2 HU	2 HU	2 HU
Cells per modules	12	12	12	12	12	12	12
Max. number of cells	204	204	204	204	204	204	204
Source ⁽¹⁾	1.0A	1.0A	5.0A	5.0A	5.0A	6.0A	6.0A
Sink ⁽¹⁾	1.0A	1.0A	5.0A	5.0A	5.0A	6.0A	6.0A
Fault simulation		✓		✓	✓	✓	✓
Current measurement µA					✓		✓
Current measurement +/- 5A	✓	✓	✓	✓	✓	✓	✓
Fast current meas. (Coulomb)			✓	✓	✓	✓	✓
CAN-Baud rate 500kBd	✓	✓	✓	✓	✓	✓	✓
CAN-Baud rate 1MBd	✓	✓	✓	✓	✓	✓	✓

⁽¹⁾ Sink and source: Values can be reached separately; not in combination. Example: If sink has 2.0A setting, then the source is only max. 2.9A (4.9A – 2.0A)

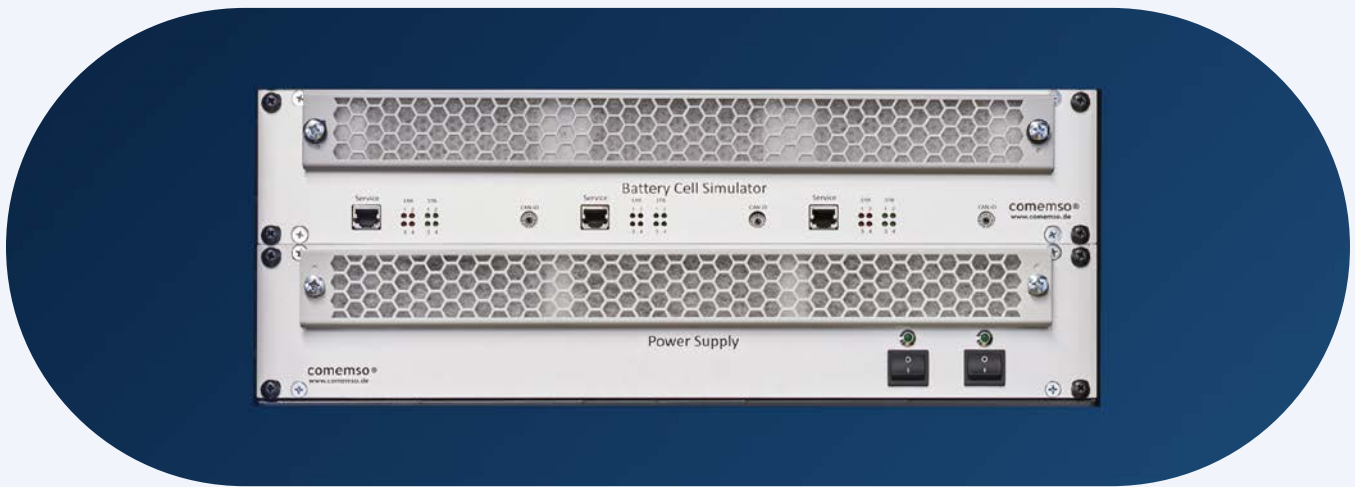

Battery management system HIL test solution

BATTERY CELL SIMULATOR BY COMEMSO®

Each comemso® BCS unit simulates 12 individual cells and combines high-precision and accuracy.

Each channel includes fault simulation for generating short circuits, cable breakage and reverse polarity, as well a high-fidelity current measurement system.

STATE-OF-THE-ART REAL-TIME SIMULATOR

All simulators support MATLAB®/Simulink®, where models of batteries, high fidelity power electronics & motors and virtual control unit can all be simulated in real-time. Possible to emulate BMS chipsets from major OEMs to virtually test isoSPI™ communication and functionality.

Our solution is available on OPAL-RT and NI PXI platforms.

ENGINEERING

OPAL-RT provides the engineering to extend the BMS HIL Test Bench functionalities; from extra protection, shunt emulation, mass interconnect, current and voltage sensing to complete vehicle control.



Benefits of real-time simulation for BMS testing.

Extend your BMS HIL test coverage with high fidelity power electronics and motor simulation at signal and power level.

Real-time simulation of power electronics remains one of the greatest challenges in HIL simulation. The I/O capability to capture high frequency PWM signals, the overall latency of the closed-loop simulation, mathematical solving of coupled switches and fault injection on all stages of complex power electronics converters are just some of the complexities of this evolving industry.

OPAL-RT brings you a scalable solution for your EV and energy storage test and research.

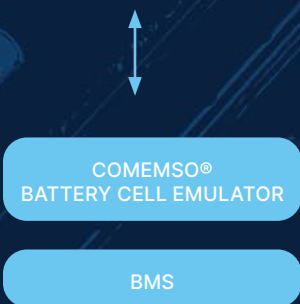
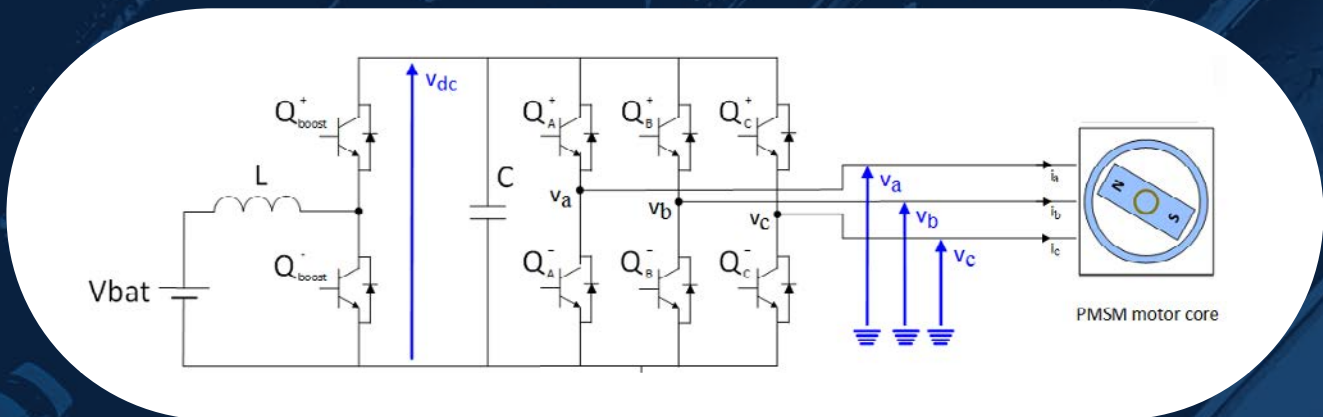

A real BMS is connected to a virtual battery pack, V_{bat}



Technical data overview

Technical data			
COMMUNICATION	TEMPERATURE RANGE	CONNECTOR	SAFETY
CAN / EtherCAT 100 Mbits/s	Lab conditions	115V/230V or CEE 3 × 16 A	Integrated emergency shutdown management
ISOLATION CELL/ COMMUNICATION	ISOLATION CELL/ CELL	NUMBER OF CELLS	CAPACITY
2kV	60V	12 to 200	Simulation of up to 144 cells per rack

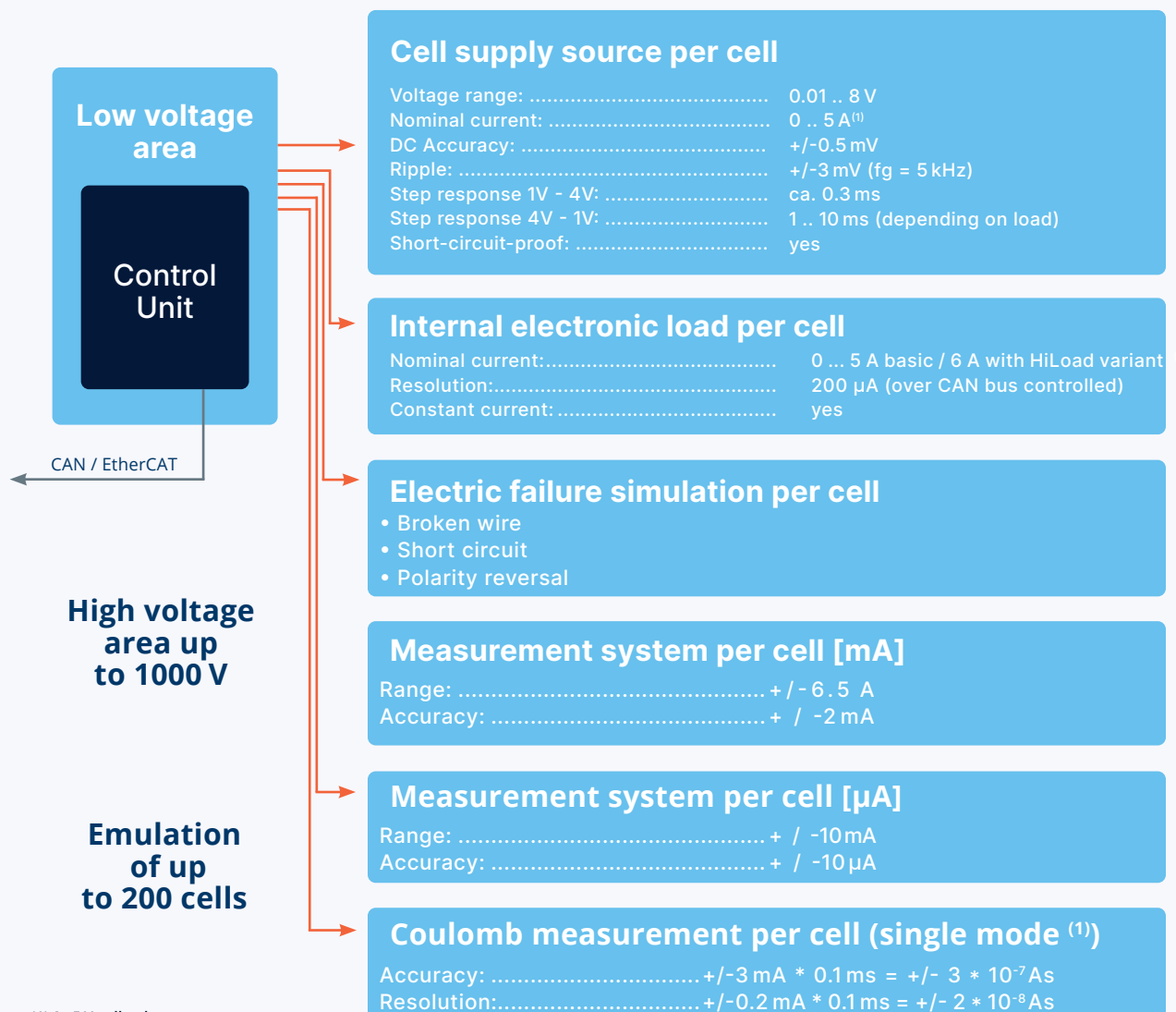

(1) At 5 V cell voltage. source is only max. 3 A (5 A - 2.0 A)



Ready to innovate?

For more than 25 years, OPAL-RT TECHNOLOGIES has been a global leader in real-time simulation and Hardware-in-the-Loop (HIL) testing. Since 1997, OPAL-RT has provided engineers and researchers with accessible, innovative, and customized simulation technologies, bridging the gap between modeling and real-world applications. By harnessing the power of high-performance computing, OPAL-RT accelerates the development of cutting-edge solutions in energy, automotive, aerospace, and other industries. Today, the company operates in more than 40 countries.



OPAL-RT
TECHNOLOGIES

opal-rt.com