



your reliant partner



Index

1 INTRODUCTION

Del Vicario, authentic Italian style	6
Mission & Vision	8

2 OUR SERVICES

Introduction	10
A summary of our services	11
Design	12
Prototyping	14
Molds and special machines	16
Machines for fences	16
Production	18
Milling	20
Quality	22

3 DEL VICARIO TODAY

Del Vicario, today	24
--------------------	----

4 DEL VICARIO GREEN

Green people, green work	26
--------------------------	----





Del Vicario engineering authentic Italian style

The most innovative technologies for industrial production meet the quality of Italian manufacturing.

Del Vicario Engineering is an engineering company specialized in metalworking. Their mission is to make customers' ideas feasible.

Del Vicario was born in 1978 by the will of its founder.

As every successful story, it was born in a garage as an artisan business, and today it is a consolidated industrial reality.

Its distinguishing feature is the passion for work; combined with experience and technological innovation, it makes Del Vicario Engineering the ideal technical partner for its customers.

The company supports its customers in the development and industrialization of new products, always considering: design, structural calculations, and technical functionality.



Market

automotive

+55%

Investment in
R&D

+4,2%

Total projects
developed

+250

Partnerships with
research centers or
schools

3

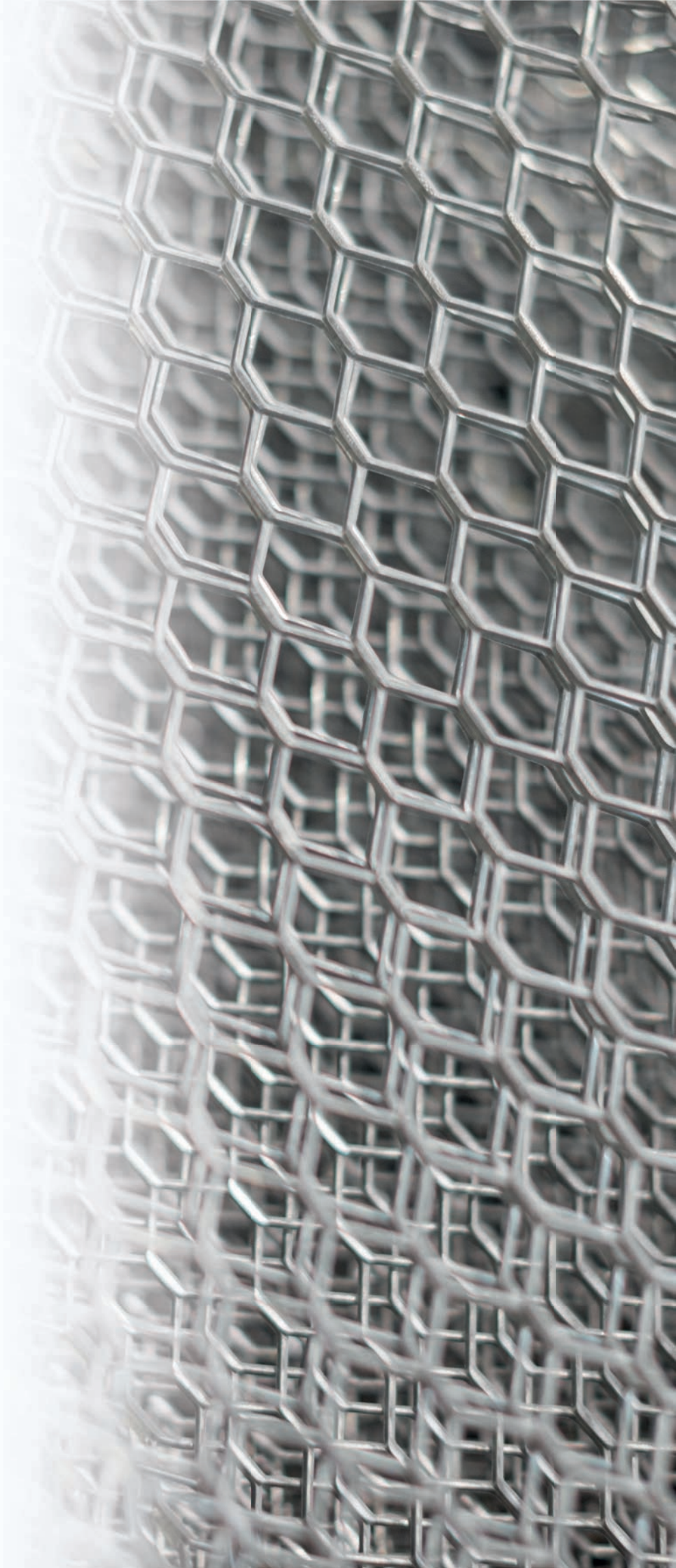

Authentic Italian style





Mission

Commitment

Ethics

Reliability

Consistency

Vision

”

The result of our
HISTORY will be
you **FUTURE**

Our services

Study, development, and production of components

Our consolidated engineering background has helped us create solid partnerships with customers and join various market segments: automotive, railway, earthmoving, household appliances, nautical.

OUR KEY STRENGTHS:

- Prototyping
- Feasibility analysis
- Assemblies
- Quality
- Co-design

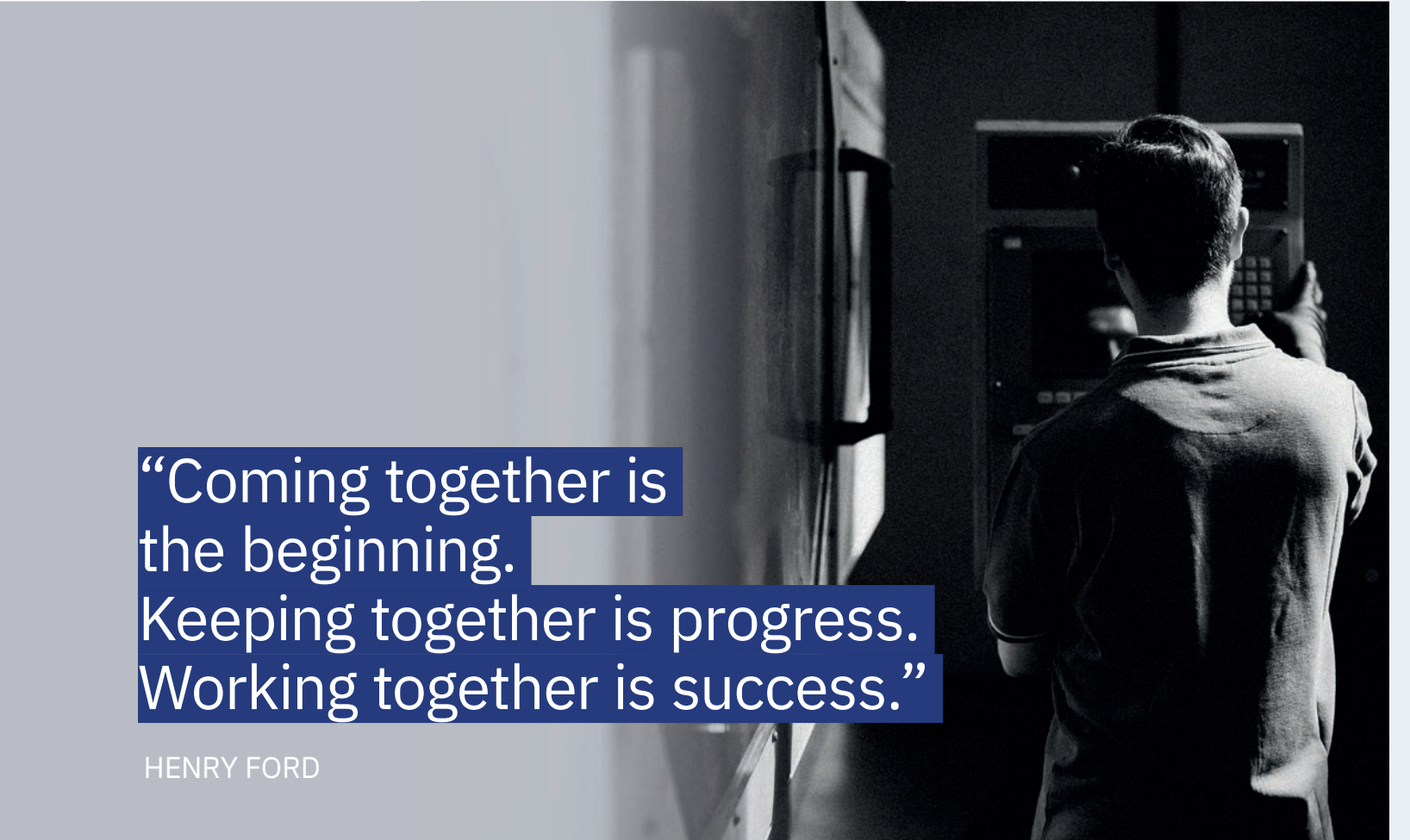
A black and white photograph of a person from behind, looking at a control panel or machine in a dark environment. The person is wearing a dark t-shirt. The control panel has several buttons and a screen. The lighting is dramatic, with strong highlights and deep shadows.

“Coming together is the beginning. Keeping together is progress. Working together is success.”

HENRY FORD

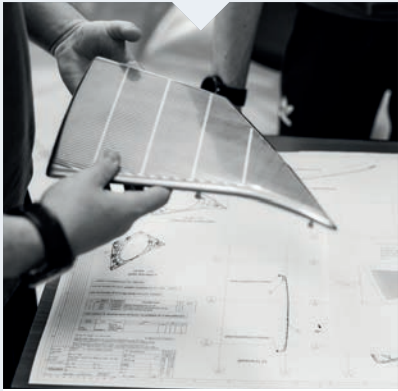

Design

Study of materials, feasibility analysis, design, engineering, design-develop technologies.

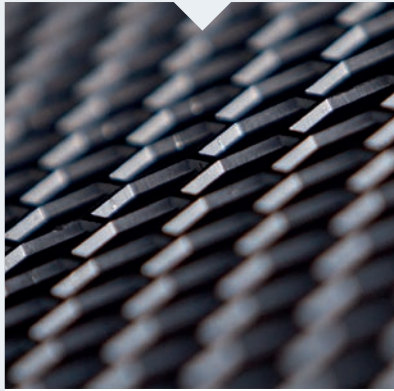

Prototyping

Where the design of the model comes to life.



Molds and special machines

A workshop with a pool of highly professional resources allows us to follow the construction cycle of special tools, molds and machines.



Production

From molding, to welding, up to the assembly of all the components of a product.

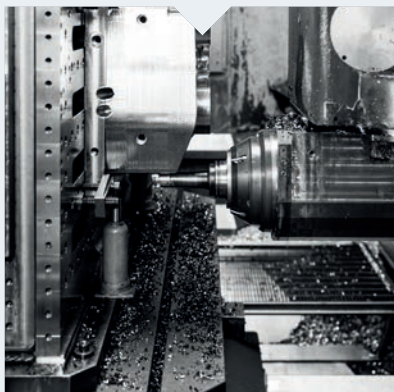

Milling

CNC milling, grinding and wire EDM machining.



Quality

Quality first. Our attention is always directed towards the supply of reliable products.

DESIGN

In this area technology and experience merge.

We provide a complete service that goes through various processing phases: from co-design, to prototyping, to the construction of the molds and finally to the processes of product optimization.

OUR TECHNOLOGY AT THE DISPOSAL OF THE SOLUTION OF PROBLEMS

The family business, the passion for work, the experience of the technical team supported by a technological heritage of cutting-edge machinery and equipment are the engine of Del Vicario.

DESIGN-DEVELOP TECHNOLOGIES- ENGINEERING

Del Vicario has developed technologies and experience in numerous industrial fields, wherever it is needed to reconcile the requests of industrial production with the sartorial quality of metal working.

How does a project start?

From the specifications provided by the customers that are transformed into a study and analysis of the feasibility of the product.

The suitable production process is shared until the product is realized.

What do we design?

Shapes

The tools and software of our technical team

- Software Think Design cad 3D/2D
- Software Autoform
- Software Tebis
- Software Cimatron
- Software Catia

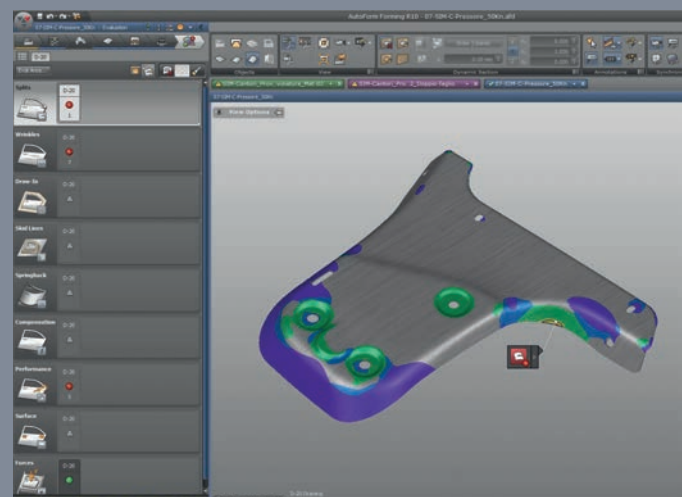
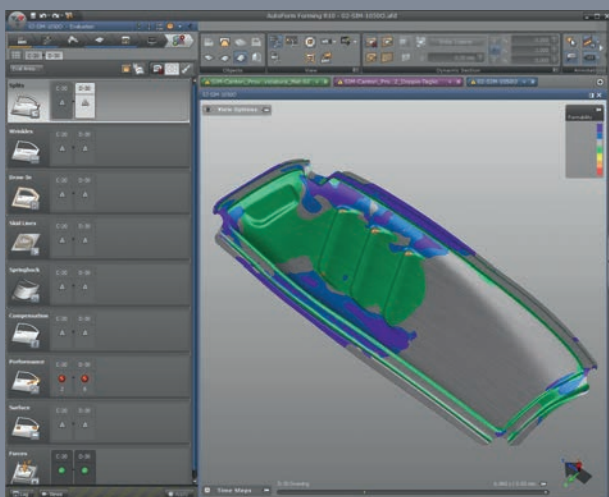

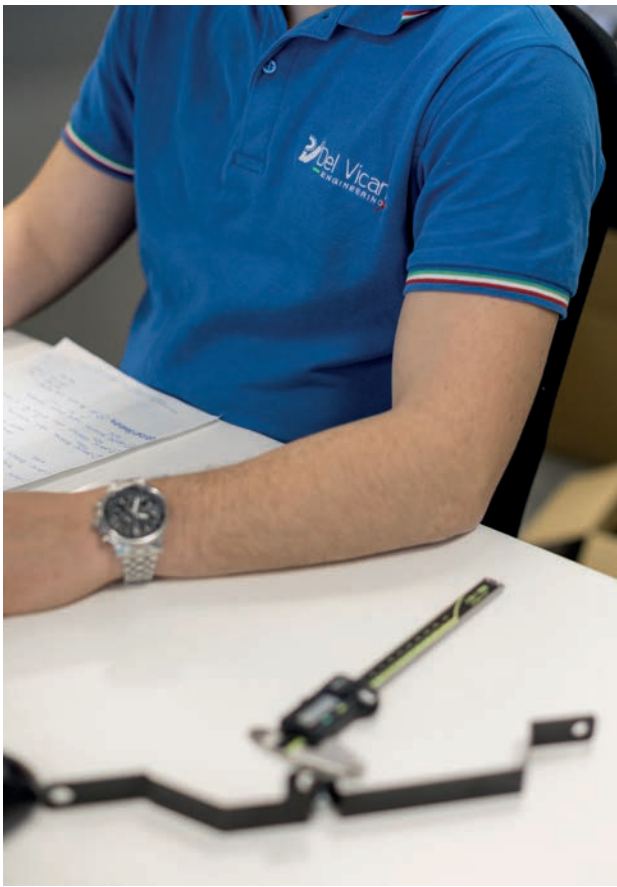
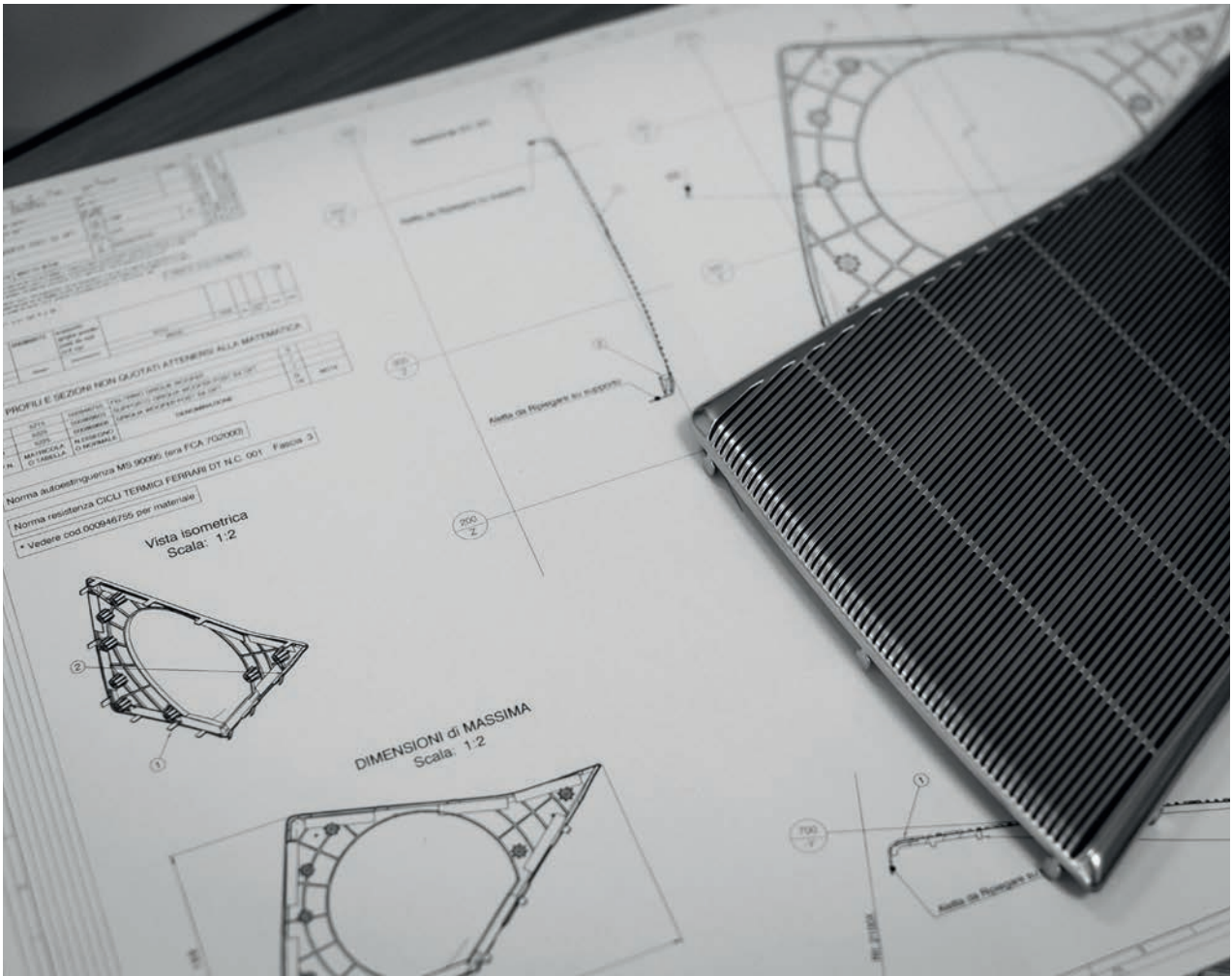

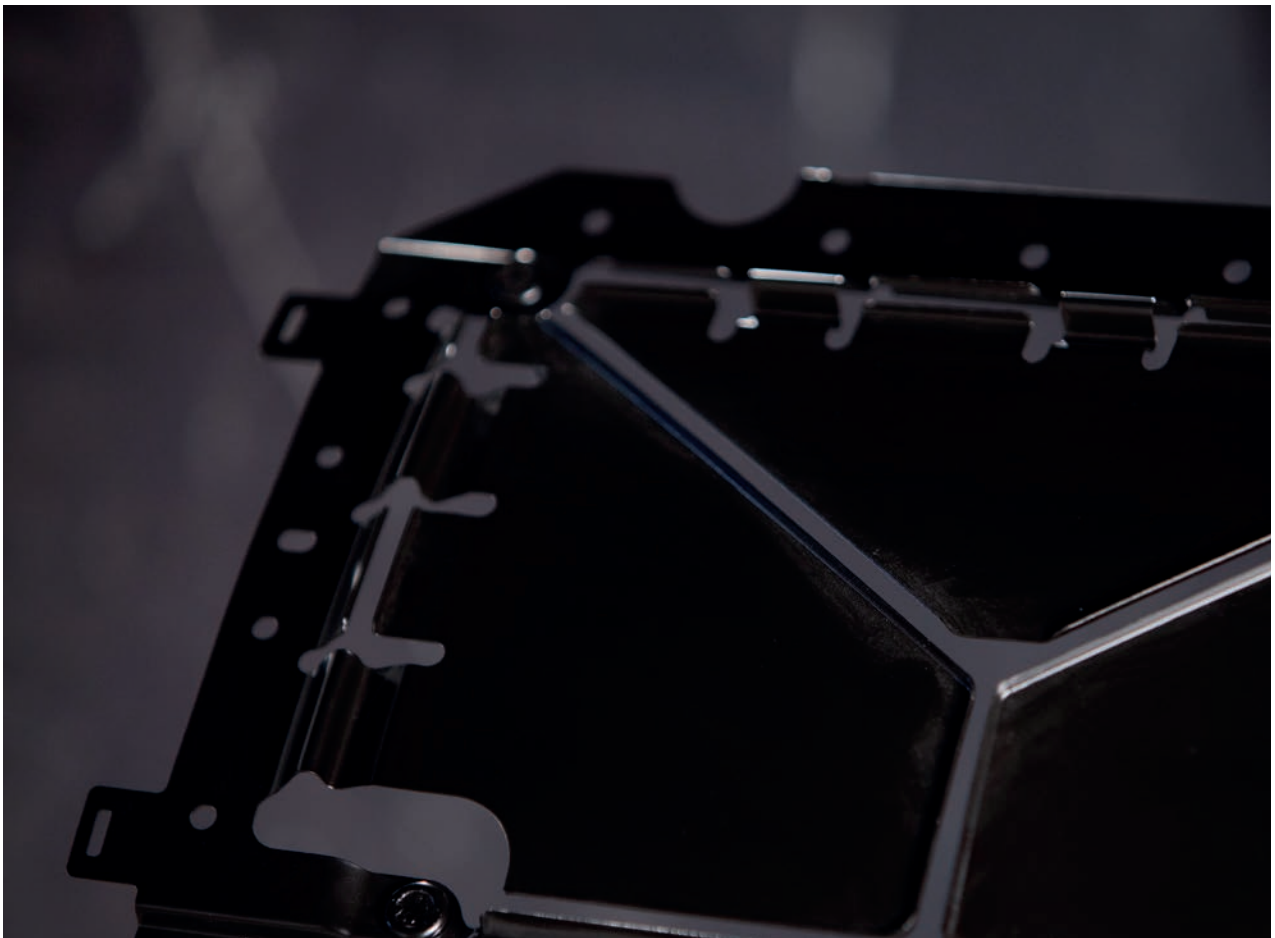
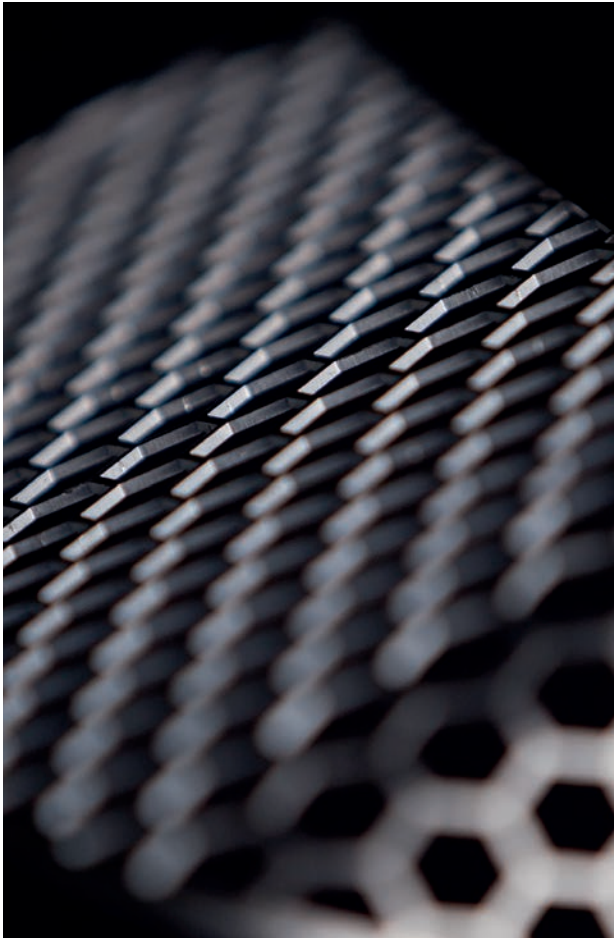

PROTOTYPING

Ideas take shape.

The streamlined and flexible organizational structure allows the agile creation of prototypes; these can be functional and/or usable not only for small productions, but also work as the basis of experimentation for mass productions.

The specific skills of our collaborators supported by the machinery of our workshop, together with the use of the latest generation systems, simulation software and 3D laser, allow the creation of items with high mechanical and technical specifications.

The purpose of innovation for small series is based on some fundamental principles:

- Lightening of weights
- Study of alternative materials
- Reduction of mold development times and costs
- Realization of pieces on-demand

MOLDS AND SPECIAL MACHINES

Innovate to grow.

MOLDS AND MACHINES

Our service starts with the design of molds.

- Block molds (cupping, punching, upholstery)
- Pitch molds
- Transfer molds

Over the years the company has specialized in the production of equipment to produce pierced and expanded metal sheets.

Meanwhile, the predisposition towards new challenges has led the company to hire workers specialized in plastics. Therefore, in recent years we have also been able to range in the world of non-metals.

This combination allows us to provide a complete and ready-to-use solution to our customer.

Another area of application of our technology is the construction of special custom-made machinery:

- Tools for gluing
- Press
- Punching for cutting mixed materials

The machines, as such, are equipped with a power supply system (hydraulic, pneumatic, electric) and are managed by PLC or specific software.

After testing and following EC laws, the machinery is equipped with safety systems and the instruction manual.

MACHINES FOR FENCES

Decoration is the essence of luxury

This product was born from the desire to diversify our sectors: it represents a real novelty in the interior design sector that replaces the traditional wall coverings. Its applicability goes from on commission to home orders.

This product is the answer to designers and architects who want to combine the request of furniture with a refined and personalized style.

THE ARTISTIC DIRECTION IS TOTALLY MADE IN ITALY.

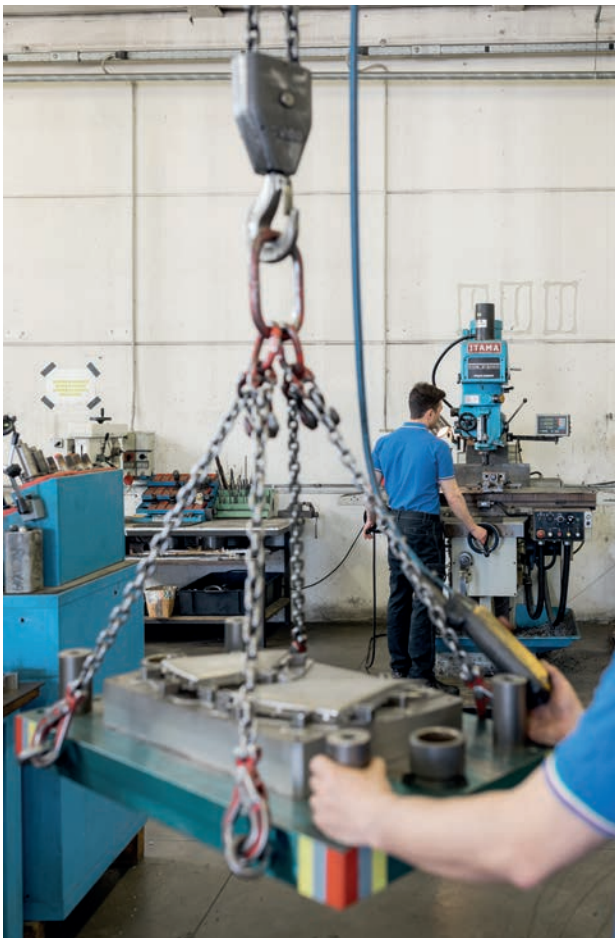
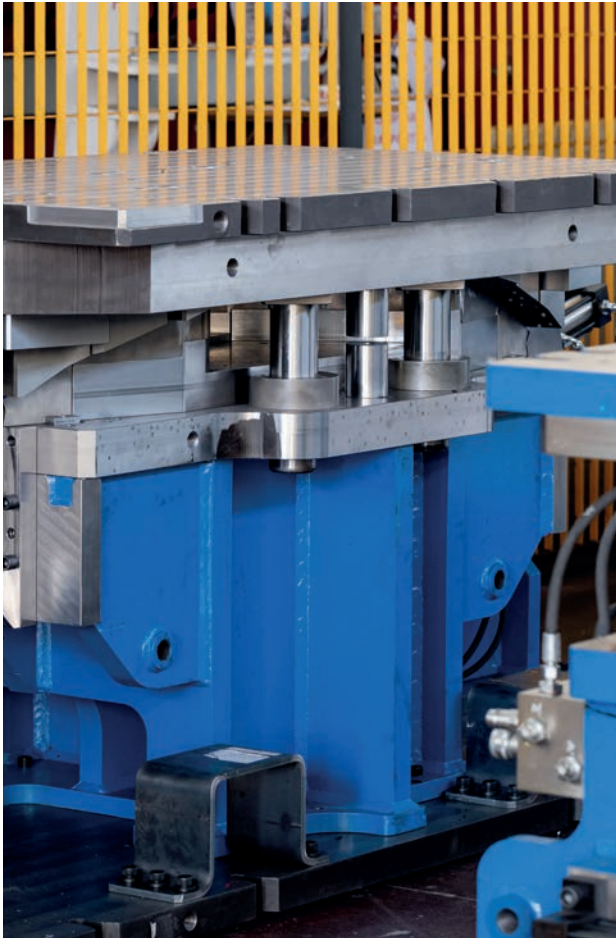

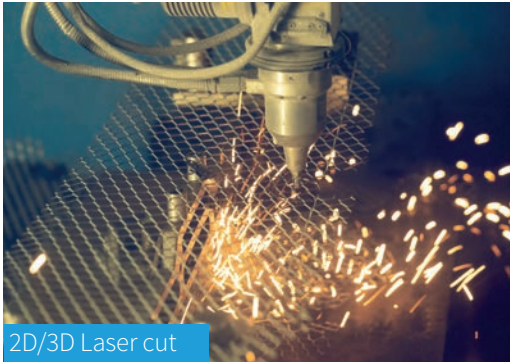

2D/3D Laser cut



CNC bending



Forging



Spot welding

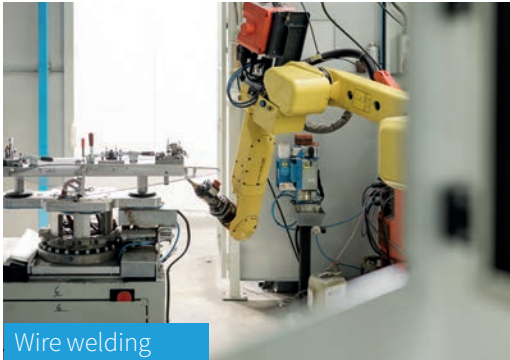

Wire welding



Assembling and finishin

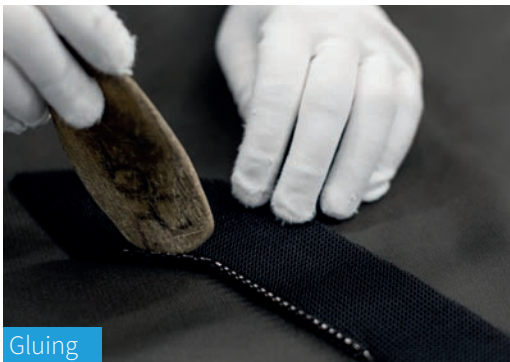

Gluing

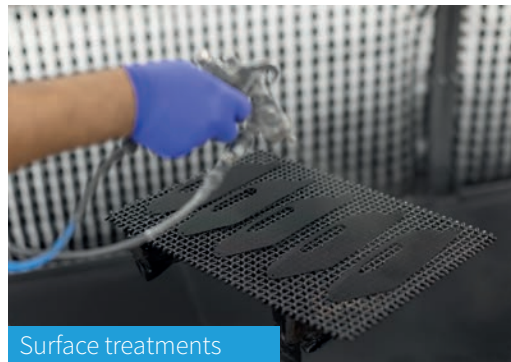

Surface treatments



Degreasing



Subgroups assembling

PRODUCTION

The customer is the most crucial part of the production process.

Over the years we have structured ourselves into various production departments to expand the range of services.

One of our key factors is the ability to take care of all aspects of the creation of a product, up to the finishing processes.

What does “offering a complete service” mean to us?

From production to molding, up to the assembly of all the components of a product: for more complex products we offer an exclusive assembly service to deliver a finished product ready for use. Our processes are designed to shorten delivery times and optimize the supply chain from production to delivery, without sacrificing quality and efficiency.

Our processes:

- Laser cut 2D/3D
- CNC bending
- Forging
- Spot welding
- Wire welding
- Degreasing
- Assembling and finishing
- Subgroups assembling
- Gluing
- Surface treatments

Our machines

- Mechanic presses from 250 up to 900 tons
- Hydraulic presses from 100 up to 250 tons
- Robotic islands for ultrasound welding, stapling welding, mig welding
- Manual stapling welding plants
- Semi-automatic degreasing plant
- Semi-automatic gluing plant
- Bender
- 3D laser
- Equipped areas for automatic and/or manual assembly of components

MILLING

" The secret of change is to focus all your energy not on fighting the old, but on building the new "

Socrate

Del Vicario Engineering is specialized in mechanical **CNC milling**, grinding and wire EDM.

Milling is performed with the latest generation CNC machines programmed using powerful Cad/Cam software (Tebis ; Cimatron), this combination allows us to quickly create complex mechanical and/or aesthetic details, in any workable material starting from 2D or 3D files. We also perform mechanical machining on cast iron parts.

Our highly specialized staff can choose from time to time the best strategies for the optimization of processes aimed at reducing production times and improving manufacturing quality; this allows us to be competitive both in the production of single parts and in the creation of small or large production lots.

Services:

- Machining 3, 4, 5 axes on multiple materials (steel, aluminum, cast iron, etc.)
- Production of particulars in series or of single particulars
- CAM programming
- Co-design for machining optimization
- Design and production of all kinds of equipment

The department includes

- **5 horizontal machining centers with 3 stroke axes (2000x800x650)**
- **2 vertical machining centers, 3 axes with rotary table (2600 x 1600 x 1600)**
- **1 Milling cutter 5 axes (1100 x 1300 x 800).**

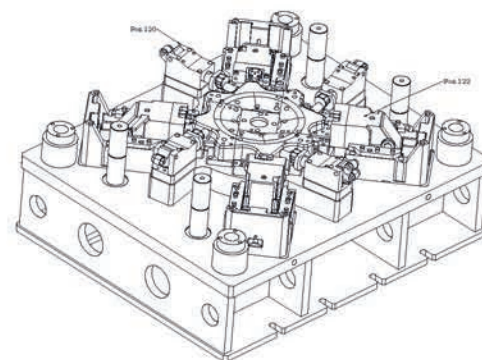
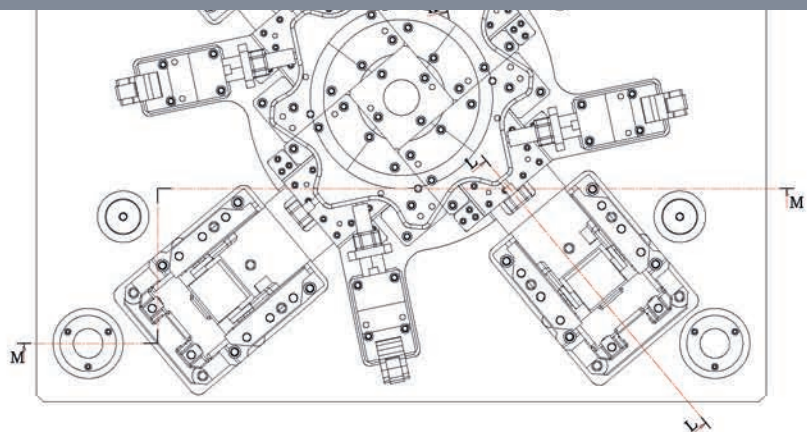

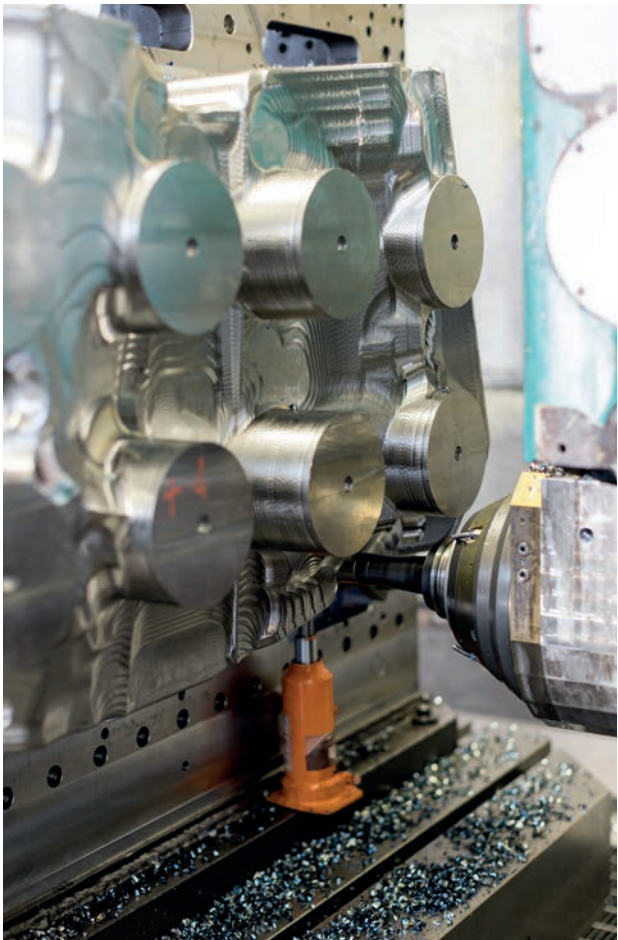
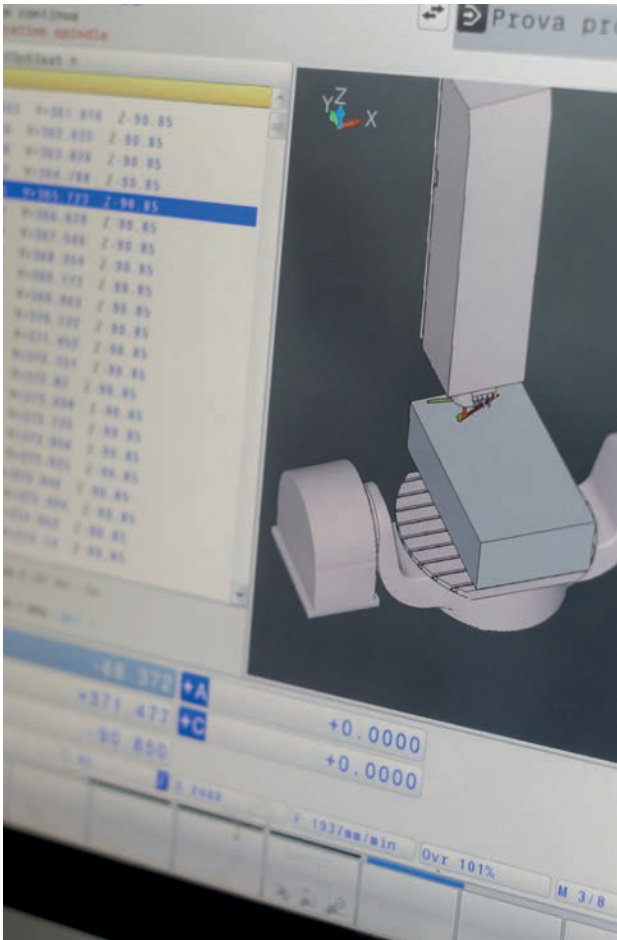

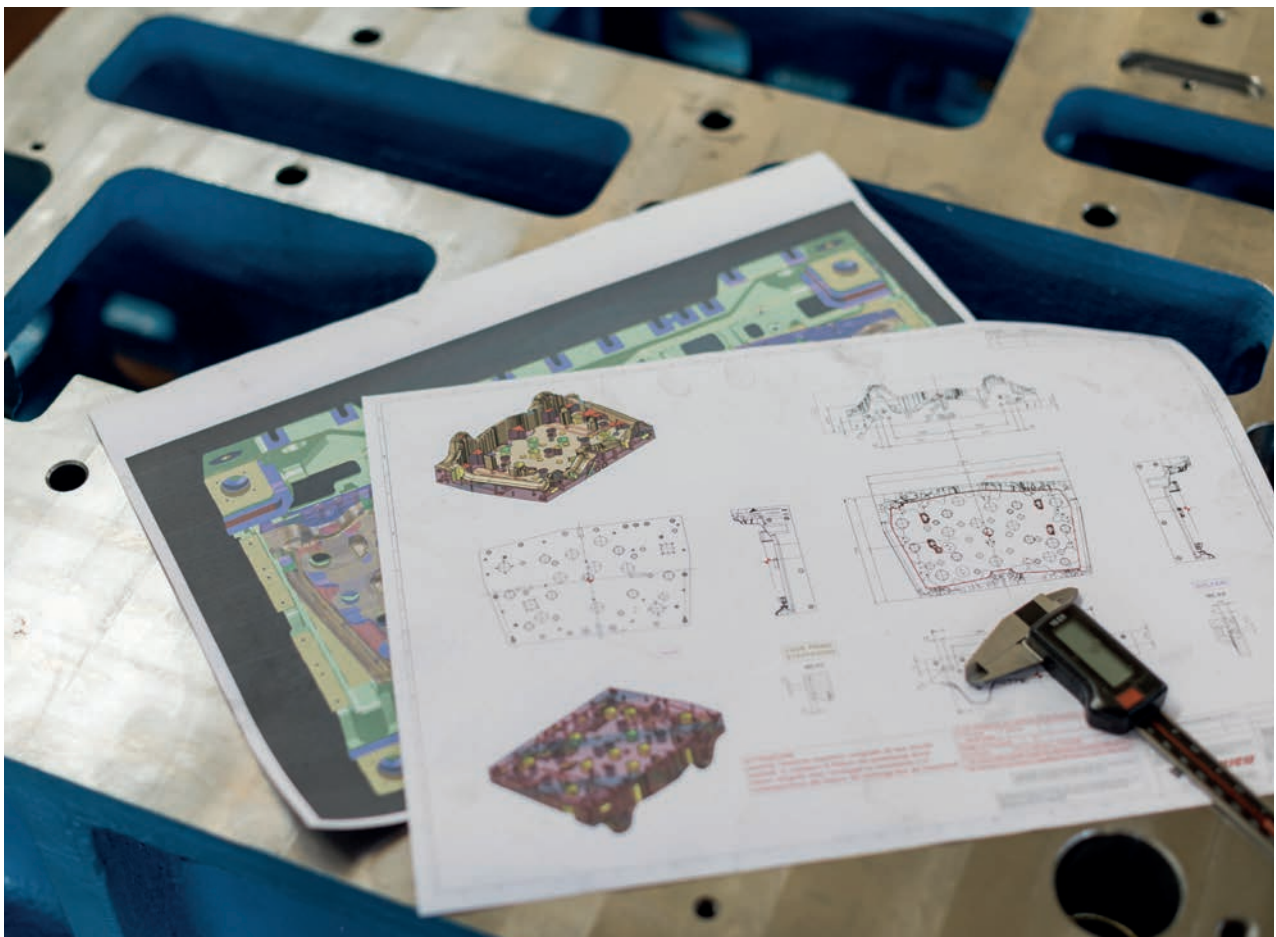

QUALITY

Quality mustn't be controlled. Quality must be realized.

The company has always been attentive to the supply of technologically advanced, reliable, and high-quality products.

The operational procedures put in place, followed by continuous checks and continuous staff training are the basis of the Quality Policy.

Along the way, the company has obtained ISO 9001:2015 certification. Today, thanks to its continuous improvement, it aims to obtain the IATF16949 certification.

A measurement and testing laboratory has been set up to ensure product compliance.

Having the control tools in place allows us a capillary control of the processes, including those managed in outsourcing.

For internal processes, each phase must undergo pass/not pass tests through self-constructed control gauges.

It is a valid support that allows us to supervise the functionality of the production lines and therefore to guarantee and validate the finished product in advance.

The laboratory is composed as follows:

- Measuring arm – "Romer Absolute"
- Altimeter
- Salt spray chamber
- Adhesion Test tank
- Thickness measurer
- Gloss evaluation
- Materials hardness control

The process of gluing completes the qualification process of a specific manufacturing. For this process, the company holds a patent, and it created internally a sound emission analysis room called Acoustic Meter.

This instrument managed and configured by software allows the calibration and optimization of the sound emission.

TODAY



Del Vicario today has 60 collaborators of whom 32% under 30.
The production area expands over 9000 square meters divided into 3 locations.

4000 mq of production plants

1000 mq of offices

2500 mq for workshop and milling

1500 mq of warehouse

The turnover keeps on growing.

These are favorable numbers which represent results that the company guards and preserves, by reinvesting continuously over the years in technology and operating spaces to keep its innovative spirit alive and to improve its lay-out.

Past, present and future goals always point to customer satisfaction, continuous improvement, technical innovation and sustainability.

30%

Invested in
technology

2

Patents

20%

invested in research and development

business chain

participation in tenders for technological
innovation

60

collaborators

32%

collaborators
under 30

9000

mq of production site

3

headquarters

Our commitment for a sustainable future



Green People
Green Work

Wind energy

Wind
power
plant
-30%
fossil energy

Totale
Kw
installed

1.120

Heat
pumps

2

WIND POWER PROJECT

Thanks to the constant commitment for the search of customized solutions, a vertical wind turbine model of the Savonius type was designed and developed.

Del Vicario Engineering in collaboration with the Department of Energy of the University of Perugia have created this model of wind turbine paying particular attention to the design, to optimize performance and allow efficient use, even in relatively windless sites.

Contacts

Address:

13, G. Capodaglio Street
62019 Recanati (MC)

Telephone/Fax:

Tel. 071 - 978766 | 071 - 7506126

Fax 071 - 7505252

Online:

www.delvicario.it
sales@delvicario.it

Science without
passion is worthless.
Work without love is
worthless.

The key to our success is to transmit our passion for work and ethical values to our collaborators.

Today we give prestige to what we are, reaping the fruits of 45 years of continuous investments on both economic and training sides.

We are ready to face the future by keeping on focusing on excellence.

