

# HYBRID SPLIT DRIVE

...the simplest way to **retrofit hybridization**. A pioneering propulsion upgrade for the maritime sector which provides

- **cost-efficient** hybridization
- **low-disruption assembly** around the existing propeller shaft
- **rapid dockside installation** with minimized vessel downtime

Experience the **patent-pending** retrofit solution that enables you to achieve **future-ready performance**, reduced emissions, and flexible operation.

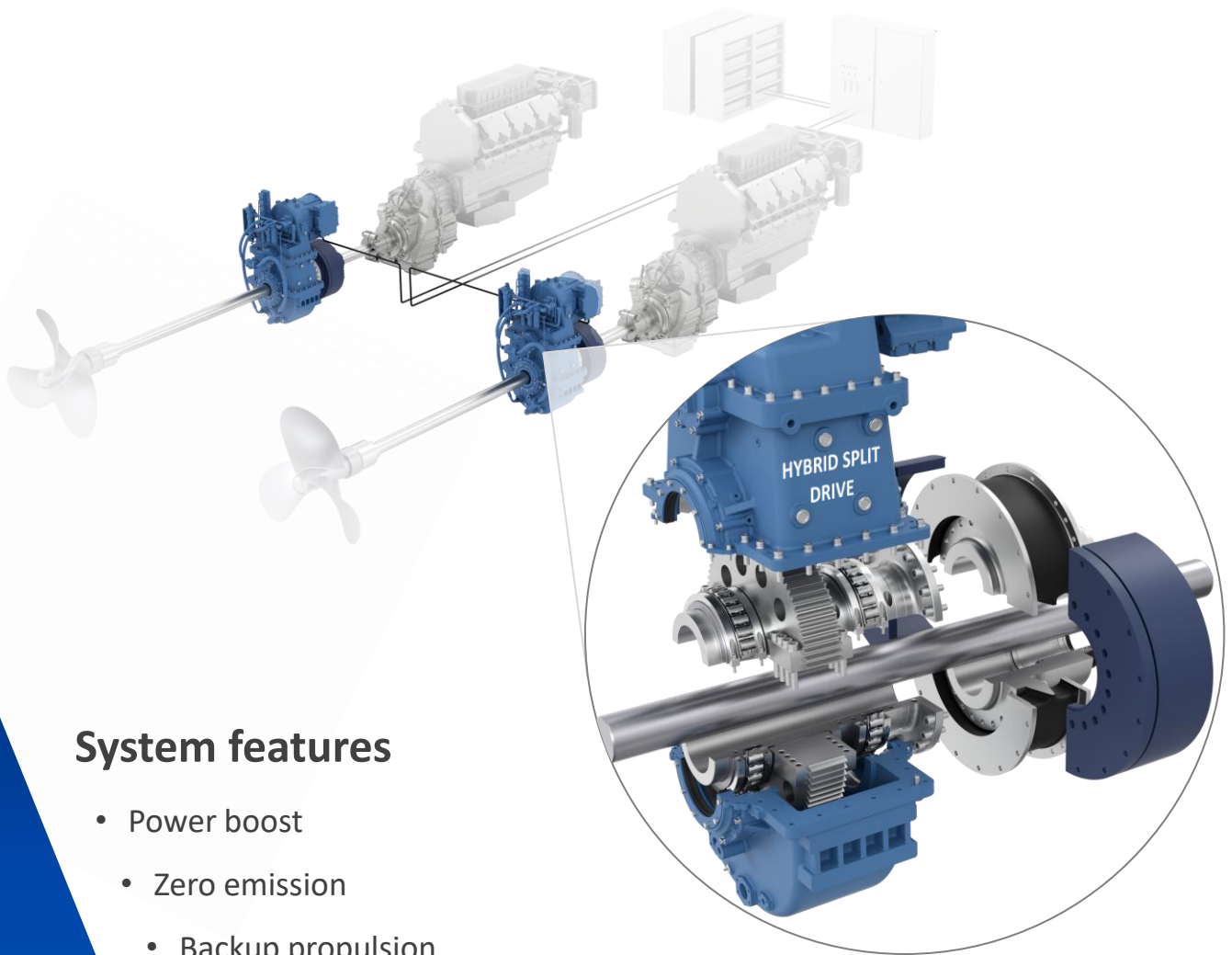

## System features

- Power boost
- Zero emission
- Backup propulsion
- Generator replacement
- Scalable propulsion power up to 500 kW

