

Romax Energy

A global efficiency prediction tool for electro-mechanical transmissions

Modern transmission system design must satisfy and balance multiple conflicting criteria, where increasing efficiency is a widely sought goal in many industries. Governments and institutions are imposing tougher legislation aiming at reducing global emissions and environmental impact. As development cycles are getting shorter, designers, analysts, and engineers need results quickly and accurately.

Appropriate software tools can help engineers to design efficient transmissions, hence reducing fuel consumption (ICE) and/or extending range (EV). Romax Energy provides robust tools for predicting power losses of transmissions for a vast range of applications (including automotive and aerospace). Our simulation methods and tools have been used and validated in numerous projects and proven to improve driveline efficiency.

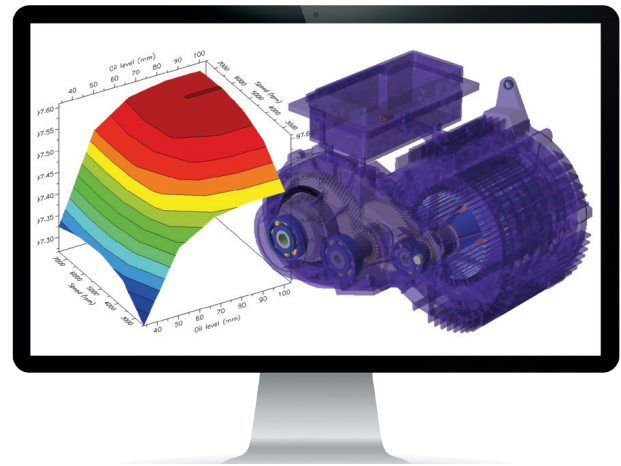

Benefits

- Meet efficiency targets by changing the design quickly, accurately, and reliably, using Romax Energy’s comprehensive efficiency models, including our advanced tribological methods, to predict power losses
- Design and optimize components for highly efficient designs by investigating and understanding the impact of varying the geometry, operational parameters, and lubricant properties on the whole system performance
- Conduct informative CFD simulations early in the design process using our democratized interface to Particleworks, with minimal expertise required, to reduce the time to market



The methodology used allows advanced parametric studies to be carried out in an all-in-one approach with [Romax software] to consider the effect of a wide range of design changes on efficiency at the same time as durability and NVH performance.” Christina Exner,

Achates Power

Romax Energy: robust methods and tools for predicting transmission power losses, integrated with Romax tools and beyond

Comprehensive efficiency models to predict transmission power losses:

- Calculate load-dependent and load-independent losses.
- Use measured drive cycle data for analysis relevant to real-life operating conditions.
- System-level reports -system efficiency maps, energy losses, equivalent fuel consumption and CO2 emissions.
- Component-level reports -power losses, efficiency, fuel consumption and CO2 emissions.

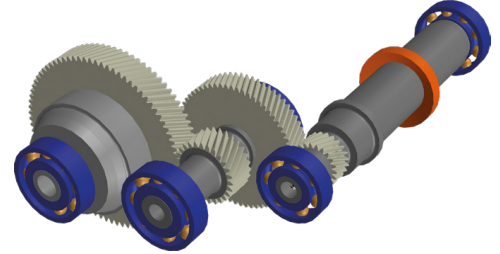

Component and system-level design for optimal efficiency:

- Parametric study to investigate the impact of parameters (e.g. torque, speed, temperature, lubricant level) on system efficiency.
- Calculate component power loss using widely-used industry methods and our own world-leading proprietary drag models.
- Investigate gear and bearing efficiency and redesign accordingly.
- Choose from an extensive lubricant database or create your own to investigate the effect of oil additive packs and friction modifiers on efficiency, and design the system for the oil and the oil for the system.
- Understand efficiency at the powertrain level and work with other Romax products to manage trade-offs with durability and NVH.

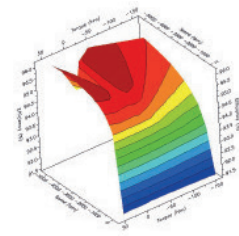

Component and system-level design for optimal efficiency:

Use the interface to Particleworks to export a fully defined Romax model with all kinematic and simulation properties defined.

Use best practises applied as defaults to set up a fully valid CFD model, with little to no CFD experience required.

Study variations of different parameters such as fill height, temperature and speed and the resulting impact on fluid distribution and churning loss. Understand system lubrication performance under extreme conditions such as hill starts or cornering, where CFD is required to analyse the fluid properly.

Obtain more accurate, high-fidelity churning loss for critical / longest operating conditions (e.g. in a drive cycle) to understand and improve system efficiency.

Use results to redesign the system to ensure proper lubrication while minimising churning loss.

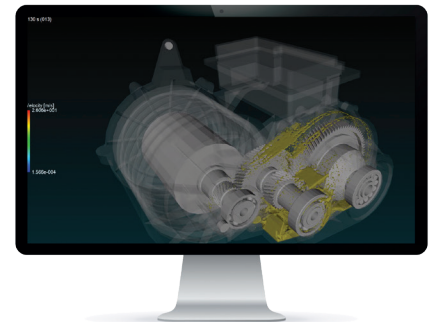

Particleworks simulation

cādence[®]

Cadence is a pivotal leader in electronic systems design and computational expertise, using its Intelligent System Design strategy to turn design concepts into reality. Cadence customers are the world's most creative and innovative companies, delivering extraordinary electronic products from chips to boards to complete systems for the most dynamic applications. www.cadence.com

© 2026 Cadence Design Systems, Inc. All rights reserved worldwide. Cadence, the Cadence Logo, and the other Cadence marks found at www.cadence.com/go/trademarks are trademarks or registered trademarks of Cadence Design Systems, Inc. All other trademarks are the property of their respective owners.