

# Innovation in motion

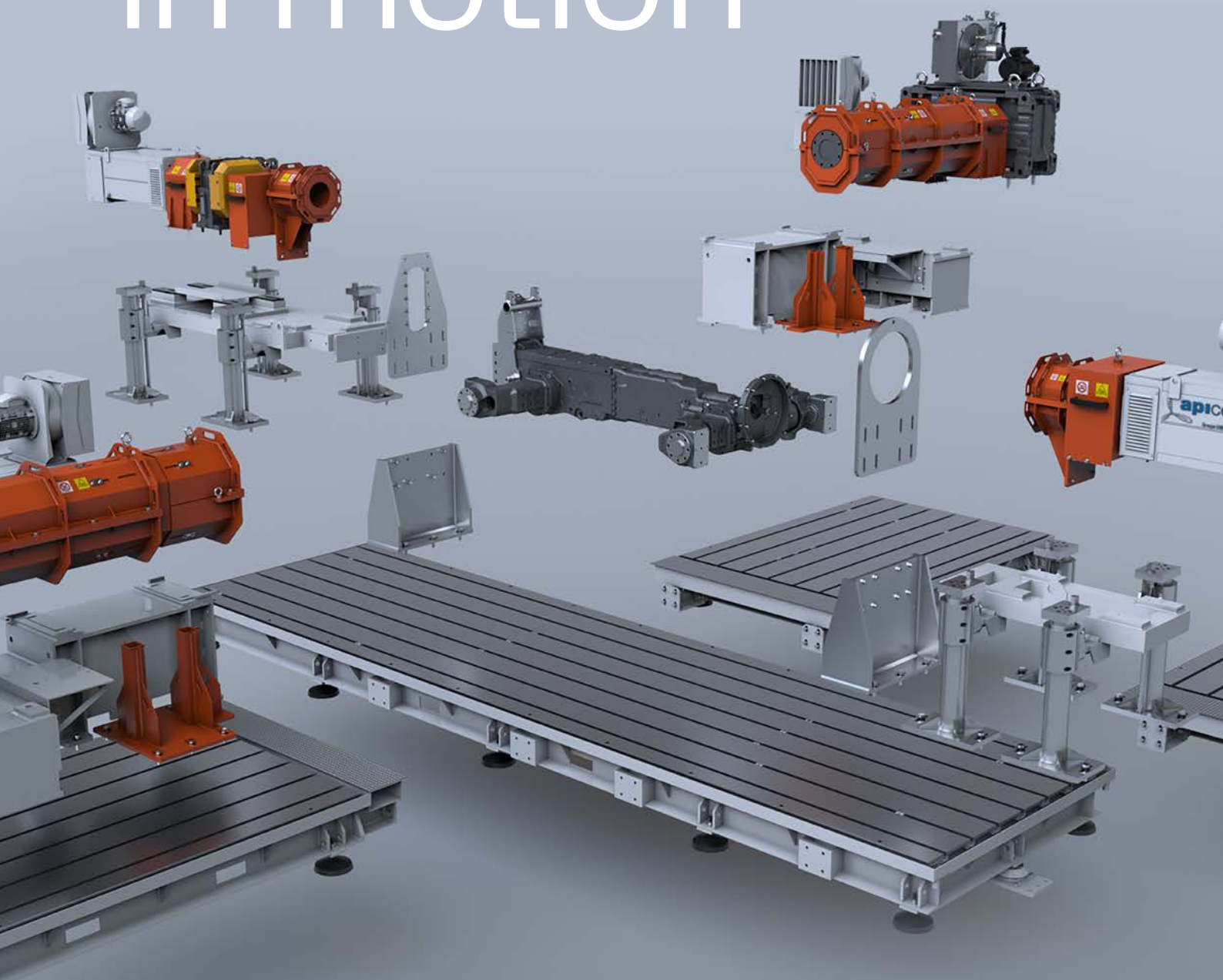



INNOVATION  
IN MOTION

# Accelerating engineering innovation.

## Evolving our Brand

Following the acquisition of Dynamometer Services Group Ltd and BETADyn, the group has reached an important milestone where the next steps forward are together as one Group, known as “Apicom Group”.

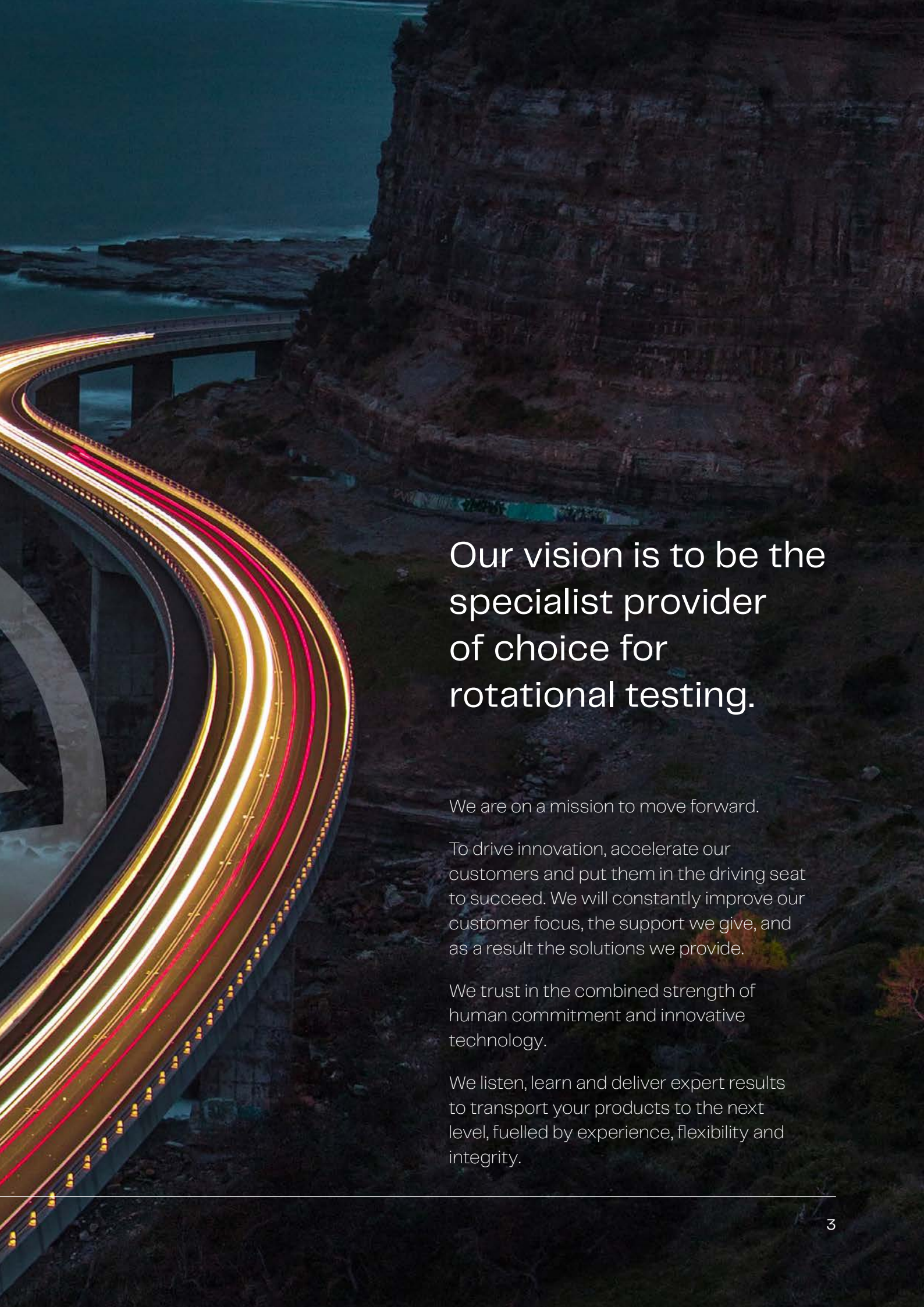

## Our vision is to be the specialist provider of choice for rotational testing.

We are on a mission to move forward.

To drive innovation, accelerate our customers and put them in the driving seat to succeed. We will constantly improve our customer focus, the support we give, and as a result the solutions we provide.

We trust in the combined strength of human commitment and innovative technology.

We listen, learn and deliver expert results to transport your products to the next level, fuelled by experience, flexibility and integrity.

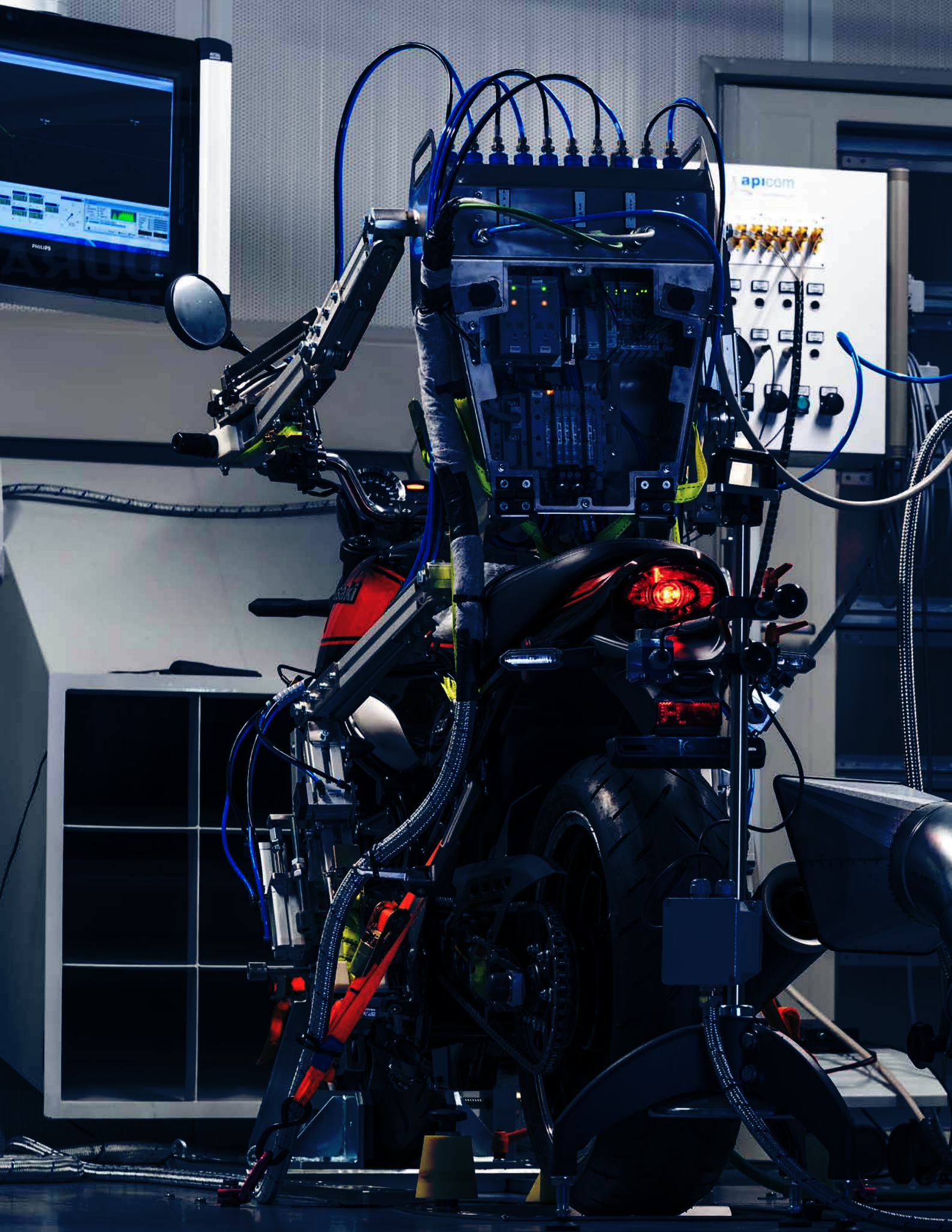



INNOVATION  
IN MOTION

**Apicom SpA is a company of Group GMB Invest / ICM completely dedicated to testing for the transportation industry.**

Apicom provides test benches and test cells for motorcycle, car, truck, engine, transmission, gear box manufacturers and offers a complete range of product and services including eddy current dyno, AC dynos, chassis dynos, test bed automation for all testing applications.

Our systems are able to test all types of fuel combustion engines, hybrid or full electric powertrain systems and all type of complete vehicles. Our capabilities include design, construction, supply, integration, installation, commissioning and maintenance of single bench, complete test cell or turn-key supply of test department.



INNOVATION  
IN MOTION

DURABILITY  
TESTING

AKIRA MOTIVIC

Kawasaki

ABS



# Test Solutions

---

Apicom have a wide range of solutions that support the development, manufacture and re-manufacture of rotating DUT's (Device Under Test). Our solutions cover a wide variety of sectors, products and test requirements.

The following pages show the main solutions that we offer, however, should your device under test rotate and require loading then we can design a solution that meets your exact requirements.

If you aren't sure what type of test solution you require then contact us to discuss our pre-engineering packages. Here we offer tailored engineering packages to work in partnership with your team to develop and fine tune your testing requirements.

## Test Solutions

### Complete Facility

---

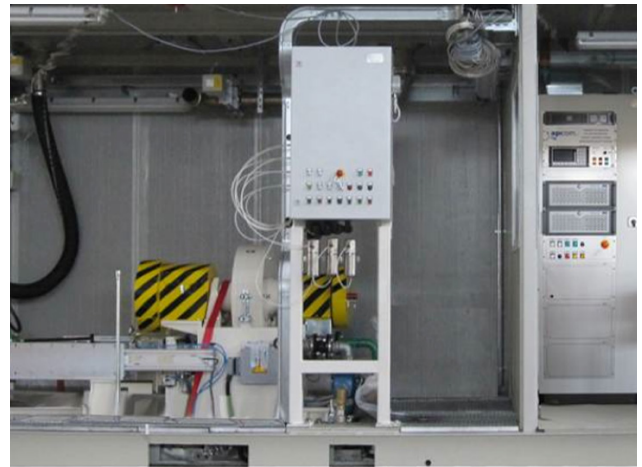
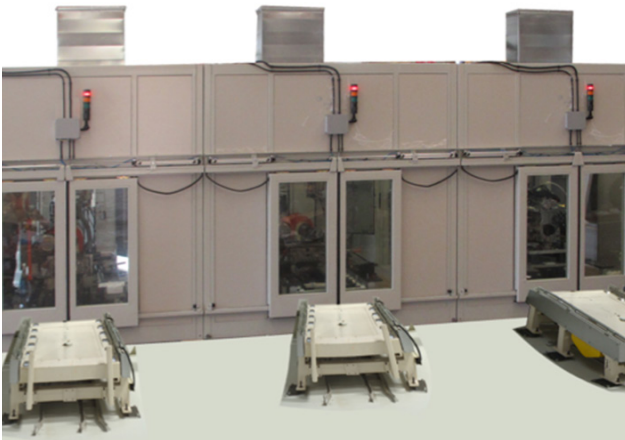

### Chassis Dynamometer

---

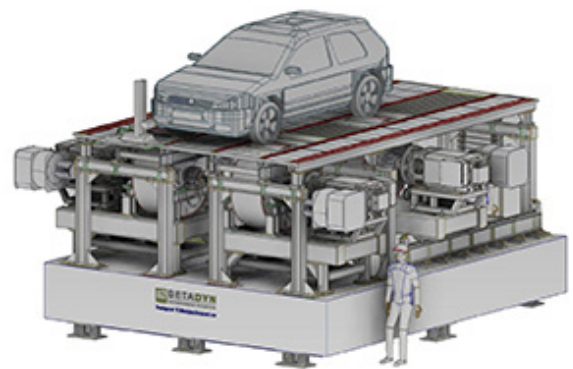

### Propulsion Test Cell

---

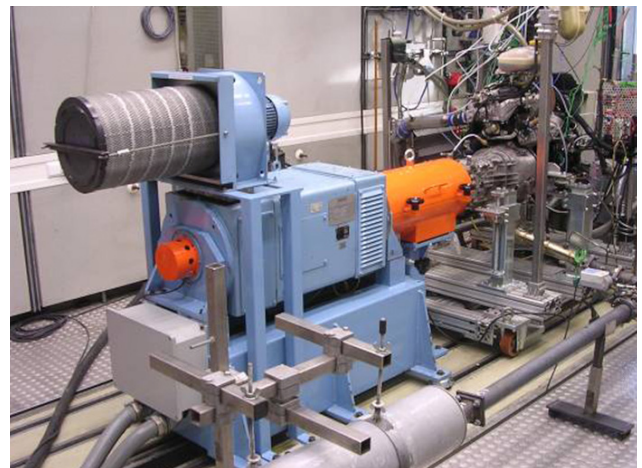

## Driveline Test Cell



## Component Test Rig



## Bespoke Test Rig

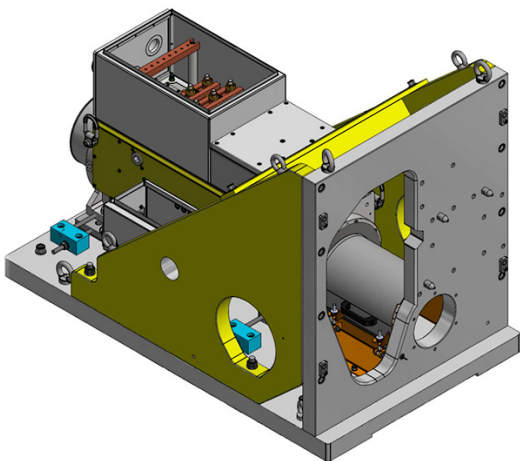



INNOVATION  
IN MOTION



# Test Equipment & Products

---

We provide test benches and test cells for vehicle manufacturers as well as a complete range of product and services including eddy current dyno, AC dynos, chassis dynos, test bed automation for all automotive testing application.



## Dynamometer

---



## Driveline

---

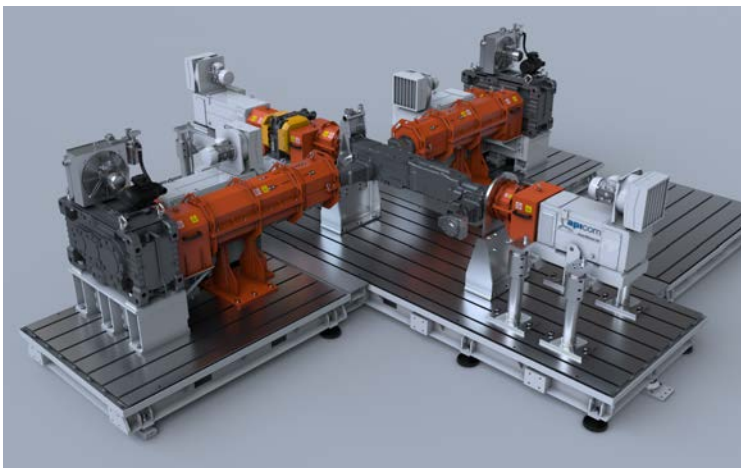

## Control System

---



## Plant & Services

---



## Pallet Solutions

---

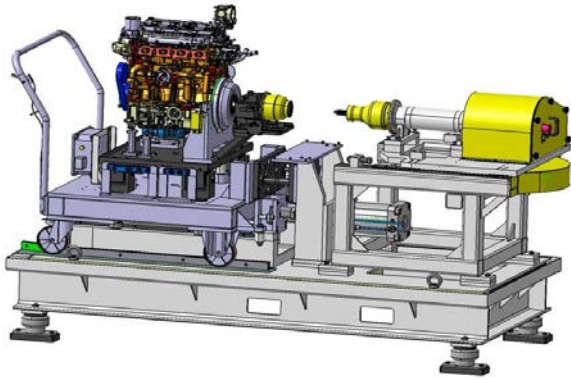

## Fuel Systems

---



## Cooling Systems

---



## SHED Chamber

---



## Battery Simulation

---

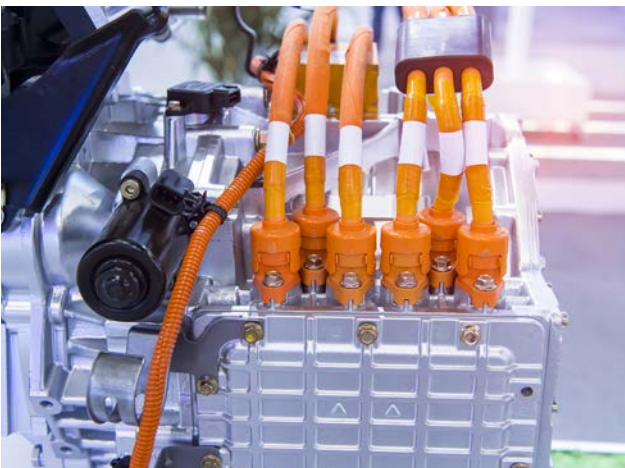

## Acoustic Treatments and Environmental Control

---



# Service & Support

---

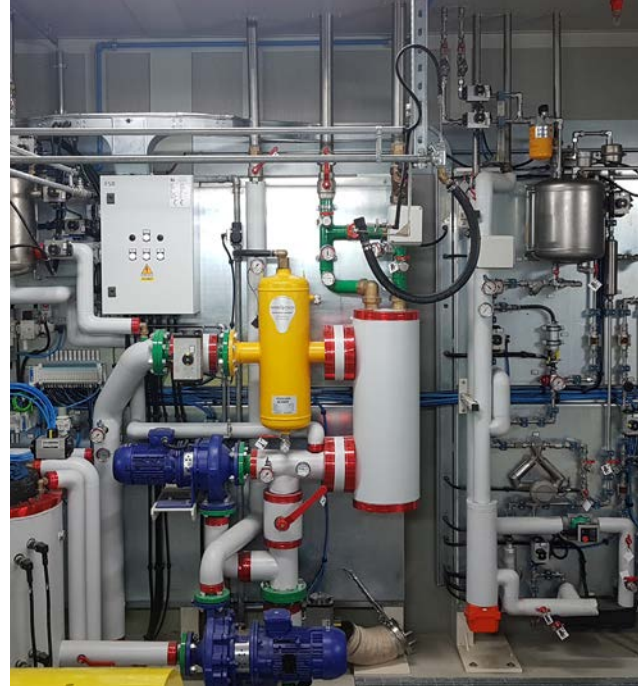

Apicom provide a wide range of service and support to ensure maximum utilisation of your facilities. Whether it be overhauling your existing equipment or breakdown visits we are there to support you.

## Equipment Repair & Overhaul

---



## Software Support

---

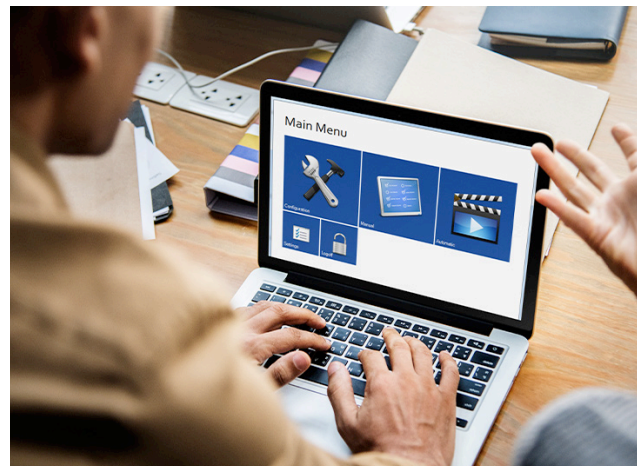

## Calibration Services



## Reconditioned / Used Equipment



## Breakdown Support



## Equipment Rental

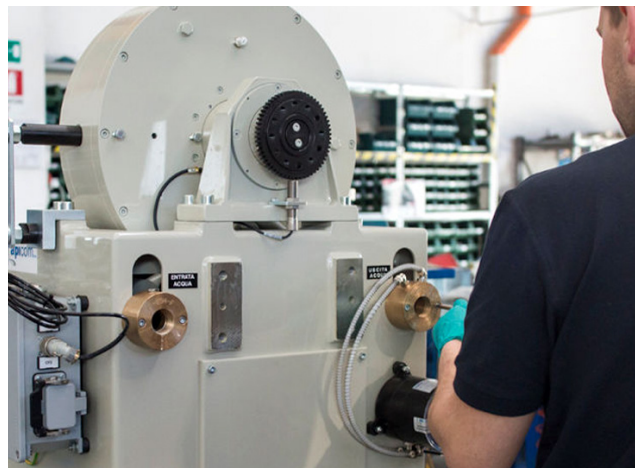

## Engineering Services

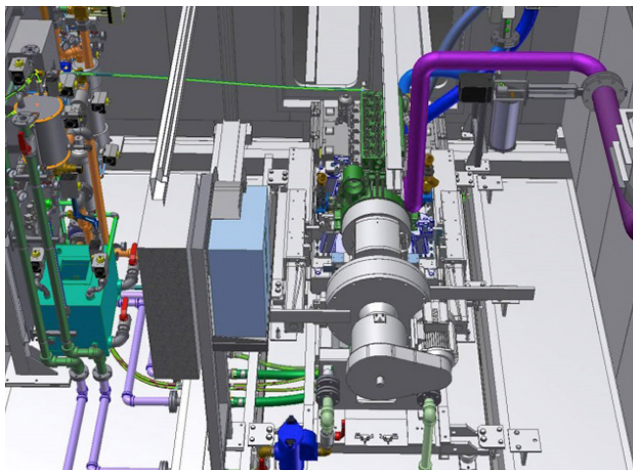
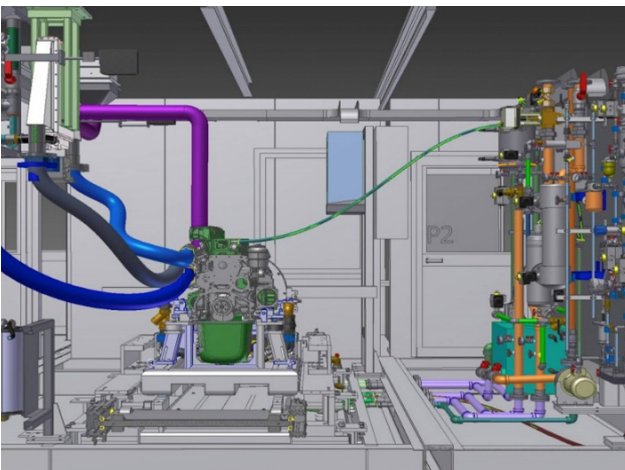



Quality consultation offered before, during and after your project.  
We have offices in Italy, Germany, United Kingdom and China.

## Italy

---

Via Statale, 20/A  
Corporeno di Cento (FE)  
44042  
Italy

Tel: +39 (0) 51 683 5273  
Email: [sales@api-com.com](mailto:sales@api-com.com)

## United Kingdom

---

Station Road  
Bransford  
Worcester, WR6 5JH  
UK

Tel: +44 (0) 1886 834 860  
Email: [sales@api-com.uk](mailto:sales@api-com.uk)

## Germany

---

Innstraße 2  
68199  
Mannheim  
Germany

Tel: +49 (0) 621 596 8310  
Email: [sales@beta-dyn.de](mailto:sales@beta-dyn.de)

## China

---

No.8 Building  
No.19 Xiangfu Avenue  
Shuangfu Street  
Jiangjin District, 402260  
Chongqing, China

Tel: +86-21-33811263  
Email: [sales@apicom.cn](mailto:sales@apicom.cn)