

#### Belgium

##### MAJOR EUROPE S.A.

Rue des Gaillettes 9  
B-4651 BATTICE  
Téléphone: +32-87-69 29 60  
Fax: +32-87-69 29 61  
E-Mail: [saleseurope@majorflexmat.com](mailto:saleseurope@majorflexmat.com)  
Internet: [www.majorflexmat.com](http://www.majorflexmat.com)

#### France

##### HAVER & BOECKER

##### Toiles Métalliques

7, Rue André Marie Ampère  
F-57070 METZ Technopole  
Téléphone: +33-3-87384476  
E-Mail: [havertoiles@haverboecker.com](mailto:havertoiles@haverboecker.com)  
Internet: [www.haverboecker.com](http://www.haverboecker.com)

#### Great Britain

##### H&B Wire Fabrications Ltd.

30-32 Tatton Court  
Kingsland Grange, Woolston  
GB-WARRINGTON,  
Cheshire WA1 4RR  
Phone: +44-1925-81 95 15  
Fax: +44-1925-83 17 73  
E-Mail: [sales@hbwf.co.uk](mailto:sales@hbwf.co.uk)  
Internet: [www.hbwf.co.uk](http://www.hbwf.co.uk)

#### U.S.A.

##### W.S. TYLER - Industrial Group

8570 Tyler Boulevard  
USA-MENTOR, Ohio 44060  
Phone: +1-440-974-1047  
+1-800-321-6188  
Fax: +1-440-974-0921  
E-Mail: [wstyler@wstyler.com](mailto:wstyler@wstyler.com)  
Internet: [www.wstyler.com](http://www.wstyler.com)

#### Canada

##### MAJOR WIRE

225 North Montcalm Blvd.  
CAN-CANDIAC,  
Quebec, J5R 3L6  
Phone: +1-450-659-7681  
Fax: +1-450-659-5570  
E-Mail: [info@majorflexmat.com](mailto:info@majorflexmat.com)  
Internet: [www.majorflexmat.com](http://www.majorflexmat.com)

## HAVER & BOECKER



DIE DRAHTWEBER

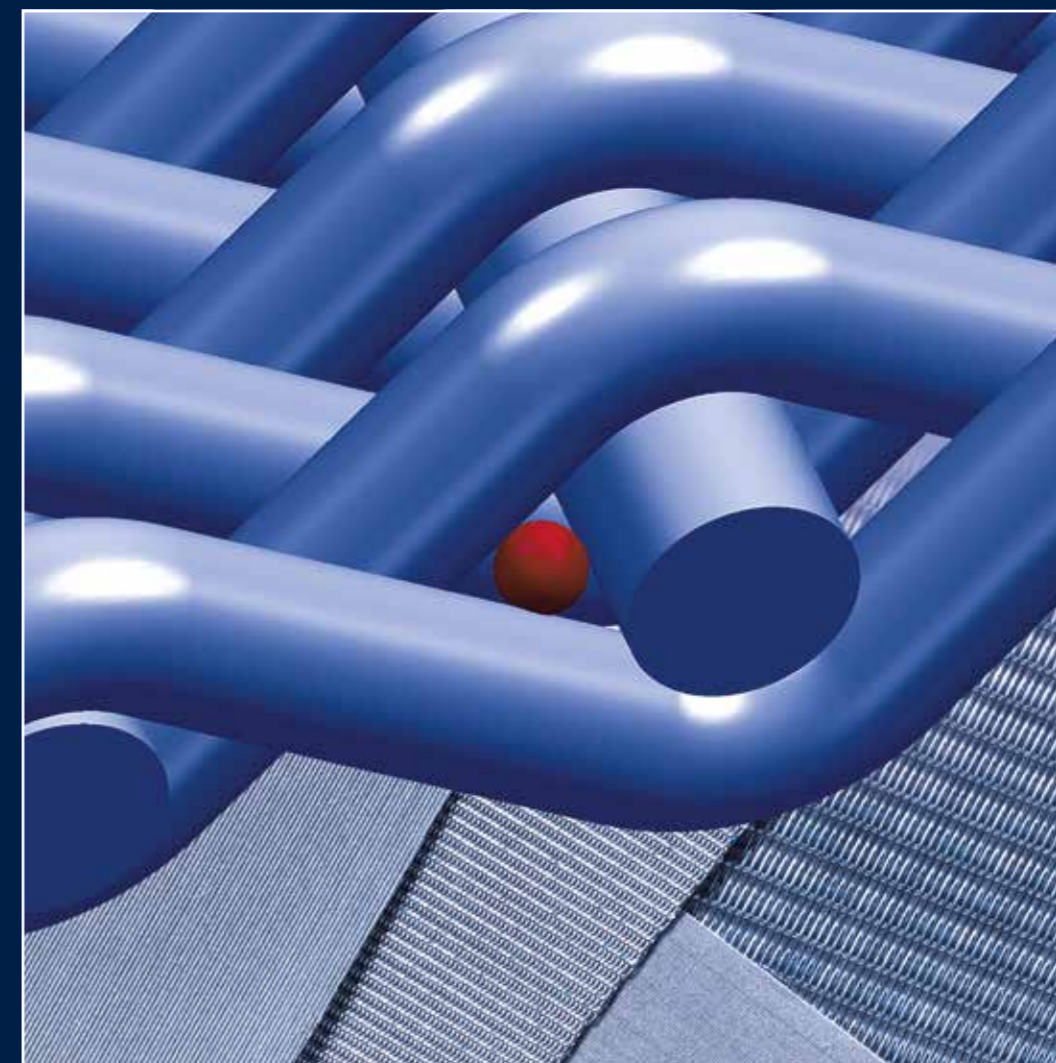

**MINIMESH® S METAL-FILTER-CLOTH.  
WITH PRECISION PORES FOR  
THE HIGHEST STANDARDS IN FILTRATION.**



HAVER & BOECKER OHG · Ennigerloher Straße 64 · 59302 OELDE · Germany  
Phone: +49-(0)25 22-300 · Fax: +49-(0)25 22-30 404  
E-Mail: [dw@haverboecker.com](mailto:dw@haverboecker.com)  
Internet: [www.haverboecker.com](http://www.haverboecker.com)

P 49 E 244 06/2015 1,5 Fe © Haver & Boecker. All rights on any kind of reproduction, in whole or part, reserved.  
Fotos: Fototeam Walkenhorst, Klaus Werner

## MINIMESH® S METAL-FILTER CLOTH.

MINIMESH® metal filter cloth from Haver & Boecker has been used as filtration media for over 100 years. It is characterised by its trouble-free production, easy maintenance and long lifespan. The geometric filter structure is completely uniform throughout the entire area when compared to fibre-based filter materials made of paper, plastic or metal. Due to the metallic material used, wire mesh filters have high mechanical strength, good temperature resistance, wettability and are extremely resistant to chemical and physical influences. MINIMESH® filter cloth is used for filtration, fluidising, drying, screening and for various thermal, electronic and acoustic applications. It is also suitable for use in all conventional fabrication processes.

### MINIMESH® S metal filter cloth with precision pores.

Using new theoretical calculation methods, Haver & Boecker has

furthered the development of the proven MINIMESH® metal filter cloth to create the MINIMESH® S metal filter cloth generation. MINIMESH® S filter cloth has an optimised pore geometry. These precision pores and the flow-optimised cloth structure lead to increased selectivity and flow capacity. The new cloths provide excellent cleanability, low blocking tendency, mechanical stability and durability.

### Faster, more stable, more energy-efficient.

The filter characteristics of MINIMESH® S metal filter cloth can be tailored precisely to the individual needs of the application. Even after processing and in highly formed areas, the predetermined characteristic is maintained. Industrial filtration processes are therefore permanently stable, precise, energy-efficient and overall economical.

### The best materials for the best woven mesh.

MINIMESH® is predominantly made of stainless steel, for example 1.4301, 1.4306, 1.4401 and 1.4404. Other materials can be used as per customer request, providing they conform to the pre-requisite metallurgical properties for extremely fine wire. You can find more information about special alloys and non-ferrous NE metals in our POROSTAR Filter Elements brochure (P 55) and Materials for Woven Wire Cloth (P 43).



Haver & Boecker began producing wire cloth in Hohenlimburg, Germany, in 1887. Today we are one of the world's leading wire weaving companies with a global network of offices and manufacturing facilities.

Our work is based upon experience, continuous research and development of our products and manufacturing processes, along with the knowledge and ability of our staff. This combination of tradition and innovation allows us to meet and exceed the high expectations of our customers.

### The formula for improved economic performance and precision.

To determine the geometric pore size, a parameter is determined that describes the diameter of a sphere that is just able to pass through the filter cloth. The pressure loss coef-

ficient for air in the laminar flow field is used to evaluate permeability. The mathematical equations upon which these methods are based were developed by Haver & Boecker in collaboration with the Institut für mechanische Verfahrenstechnik

[Institute for Mechanical Process Engineering] at the University of Stuttgart under the AVIF projects A224 and A251 and confirmed experimentally by the glass-bead test and air flow measurements.

$$\left[ \left( \frac{1 + \frac{d_s}{d_k}}{\frac{p}{d_k}} \right)^2 - 1 \right] \left( \frac{x_{max}}{d_k} \right)^2 + 2 \left[ \left( \frac{1 + \frac{d_s}{d_k}}{\frac{p}{d_k}} \right)^2 \left( 1 - \frac{p}{d_k} \right) - \frac{d_s}{d_k} \right] \frac{x_{max}}{d_k} + \left( \frac{1 + \frac{d_s}{d_k}}{\frac{p}{d_k}} \right)^2 \left( \frac{p}{d_k} - 1 \right)^2 = 0$$

## A DISTINCT ADVANTAGE: RELIABLE FILTRATION PROPERTIES.



### Another milestone in the design of filter cloth.

Compared to other filter media, filters made of wire mesh offer a distinct advantage: their specific properties can be precisely described and defined geometrically by the weave type, wire diameter and mesh count. Without the need for expensive measuring equipment, the geometric

pore size and permeability can be calculated precisely in advance. This makes it possible to determine the right cloth specification for the specific application and creates the optimum conditions for manufacturing and reproducing customised filter elements, precisely and economically.

### Advantages of MINIMESH® S filter cloth:

- Precise filter characteristics
- Flow-optimised cloth structure
- Precise cut point
- Glass-bead tested precision pores
- High flow rate
- Easy cleaning
- Low blocking tendency
- Long filter service life

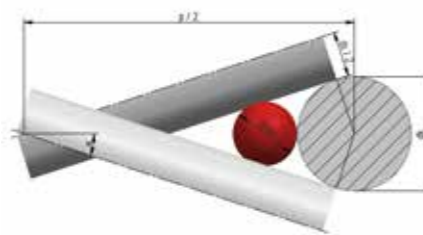

## HIGH PERFORMANCE: PRECISE CUT POINT THANKS TO PRECISION PORES.

Mathematically defined in advance, the pore size of the corresponding MINIMESH® specification is validated using established evaluation methods. The glass bead test has become an established and authoritative cross-industry test method for

determining the maximum pore size („filter cut point“). Based on this method, the independent, internationally renowned testing institute Whitehouse Scientific has tested the MINIMESH® filter cloth and confirmed the outstanding properties

of this new generation of filters. For very fine cloth with pore sizes < 20 microns in particular, the high degree of uniformity of the „precision pores“ has a distinct effect.

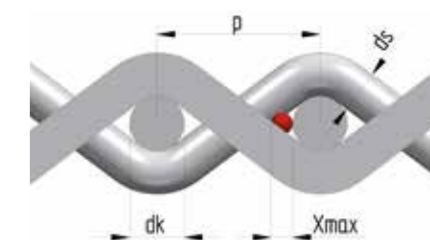
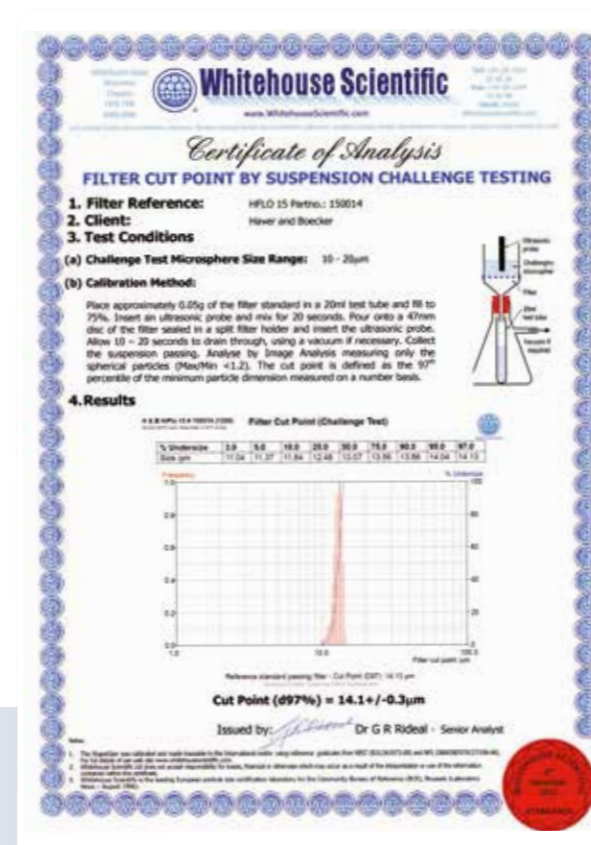

The heart of the MINIMESH® S filter generation: Precision pores with precisely defined geometry.

As an additional quality assurance measure, MINIMESH® S metal filter cloths are bubble point tested. According to the customer's wishes, the determination and specification of the filter characteristics is performed using „1st bubble“ or „mean pore size“ or both of these parameters.



## AN IMMACULATE SOLUTION: IMPROVED PURGING AND LESS BLOCKING.

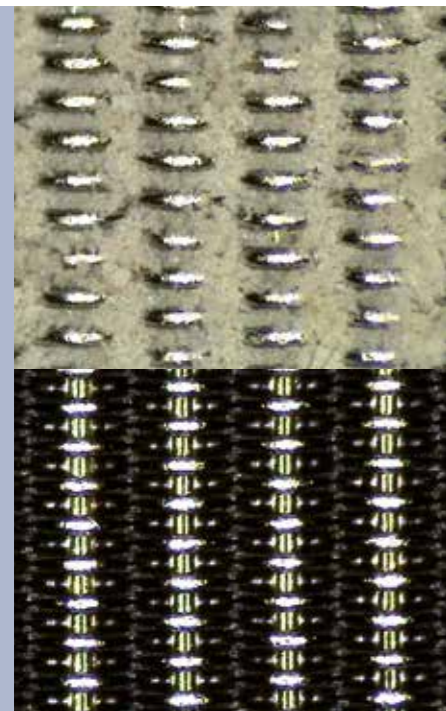

Dirt holding capacity of a HIFLO 30-S.  
above: loaded  
below: unloaded

With MINIMESH® S metal filter cloth, the desired filtration effect and flow rate are maintained significantly longer than with conventional filter media. The blocking tendency is low and cleaning is easier. This leads to long-lasting, precise filtration and a longer service life of the filter elements.

The verification of these properties has been carried out in collaboration with the Institut für Mechanische Verfahrenstechnik [Institute for Mechanical Process Engineering] IMVT. This includes air flow measurement, in which the pressure difference is measured as a function of the flow rate, the determination of the separation efficiency, the dirt holding capacity with test dust according to ISO 12103 and the purging properties measured in accordance with VDI 3926 Type 2.

To demonstrate the high degree of purity of MINIMESH® S filter cloth, Haver & Boecker uses a standardised residual contamination analysis system that differentiates the detected particles according to the categories metallic, non-metallic and fibrous.



## ALWAYS MORE EFFICIENT: GOOD PERMEABILITY AND LOW PRESSURE LOSS.

When a fluid flows through a filter medium, a pressure difference is generated between the inlet and outlet sides. This is dependent upon the geometry of the filter, the load and the properties of the fluid. Haver & Boecker specifies the value zeta ( $\zeta$ ) as a parameter for evaluating the permeability for fixed flow data. This pressure drop coefficient is valid for a flow rate of 1 m/s. The smaller zeta, the lower the pressure drop.

$$\text{(zeta)} \quad \zeta = \frac{\Delta p}{\frac{\rho}{2} \cdot v^2}$$

$$\text{with } v = 1 \frac{m}{s} \\ \rho = 1,2041 \frac{kg}{m^3} \text{ (medium air)}$$

Even within the small pore size range, MINIMESH® S metal filter cloth achieves a high flow rate with low pressure drop. These highly beneficial properties contribute to greater energy efficiency and cost-effectiveness throughout the filtration process.

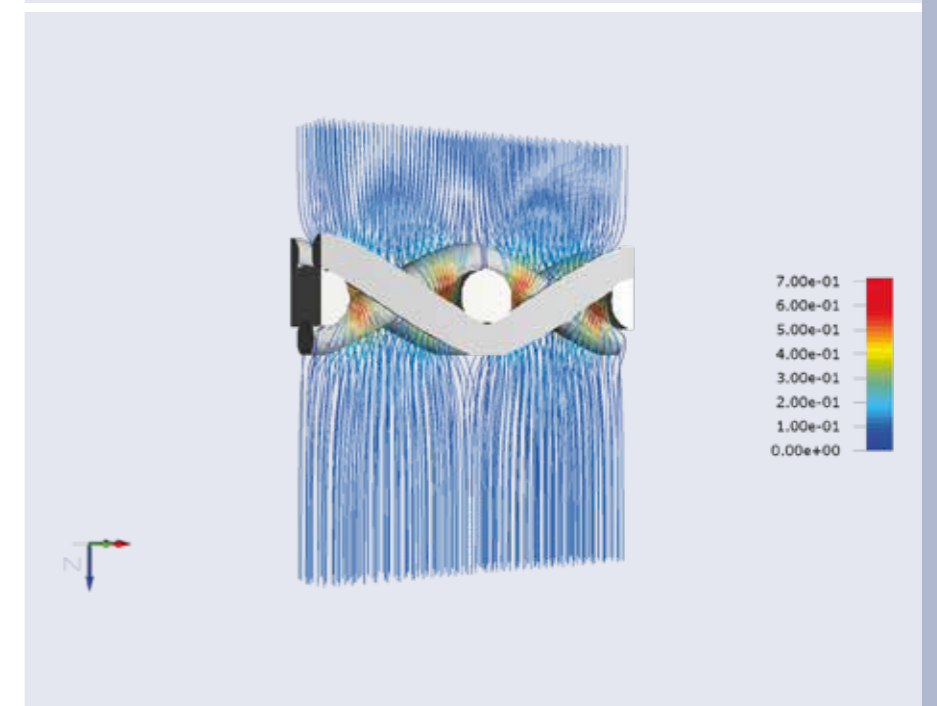
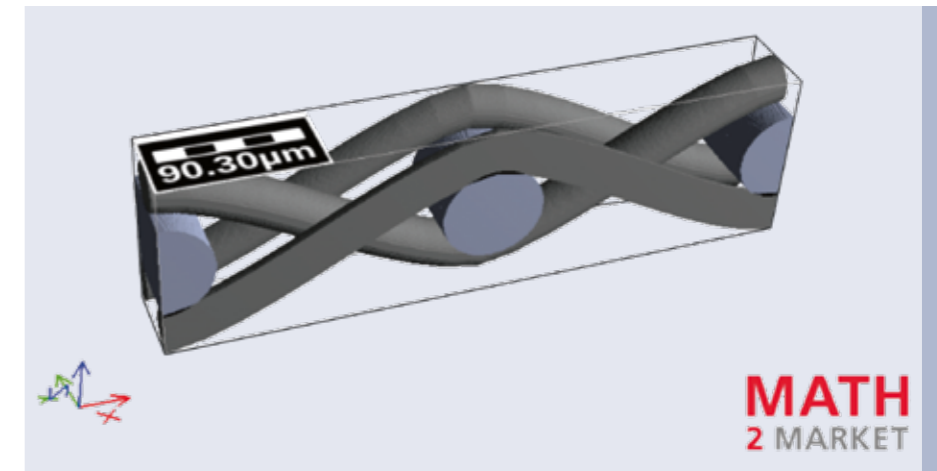

The cloth structure of the MINIMESH® S metal filter cloth is flow-optimised.

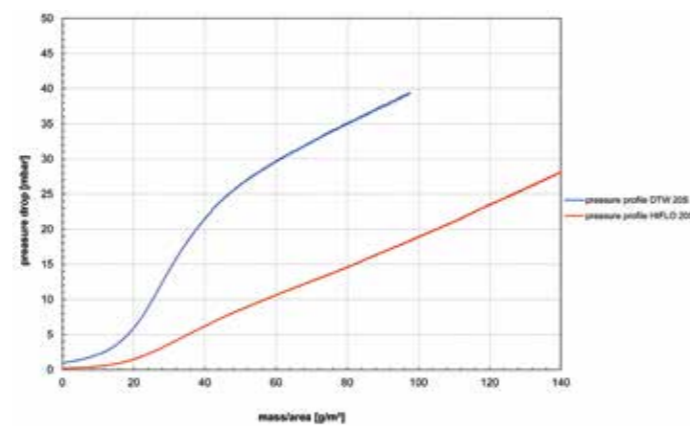

Dirt holding capacity with test dust according to ISO 12103

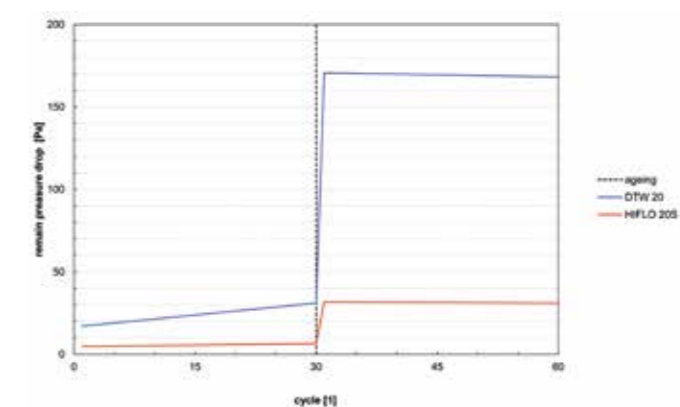

Purging properties according to VDI 3926.

## MINIMESH® SPW-S – SINGLE PLAIN DUTCH WEAVE.

### SPW – Single Plain Dutch Weave.

The weft wires are woven in a plain weave without a space between the weft wires (aperture width is 0). There are approximately 5 times more weft wires with respect to the number of warp wires. Hence the strength is higher in the weft direction. The SPW filter weave is used for surface filtration and is characterised by its ease of cleaning and back flushing. The pore size of the most common MINIMESH® SPW filter mesh cloth is within the range of 40 µm and 300 µm. To reduce pore size, single and double warp wires are used. Because of its robustness and good flow properties, it is suitable for almost every application – whether

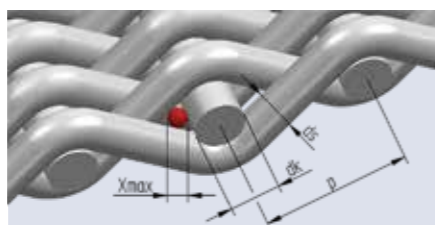

as a filter for separating solids from a viscous phase, for minimising sound or other applications that require ease of use.

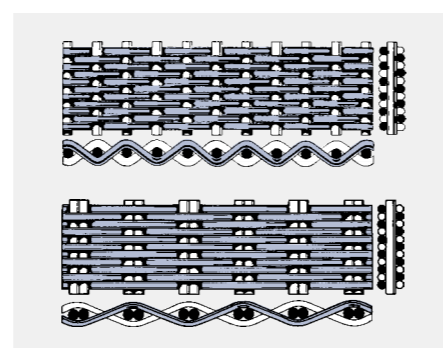
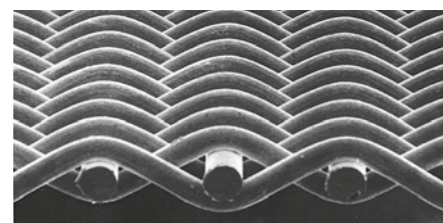
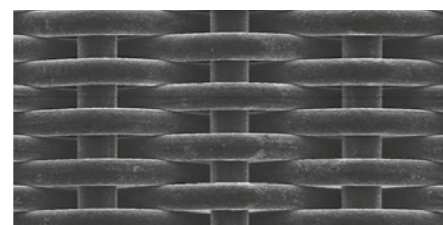

Notes on the SPW-S table:  
Column 3: largest geometrical determined pore size, tolerance ± 5% (AVIF-Project A224, A251)

1	2	3	4	5		6	7	8
Type of weave	MESH	Geometric pore size µm	Pressure drop-coefficient ζ	Tensile strength warp N/cm	Tensile strength weft N/cm	Porosity theor. %	Weight kg/m <sup>2</sup>	Cloth thickness mm
SPW 30-S	120 x 620	30	190	145	245	60	0.43	0.14
SPW 40-S	90 x 460	41	145	170	310	61	0.54	0.18
SPW 50-S	72 x 380	50	125	210	375	61	0.67	0.22
SPW 60-S	60 x 300	61	105	265	455	61	0.83	0.27
SPW 70-S	52 x 280	70	95	305	480	61	0.93	0.30
SPW 80-S	45 x 230	81	85	355	600	61	1.11	0.35
SPW 90-S	40 x 200	91	80	405	675	61	1.26	0.40
SPW 100-S	35 x 190	103	70	415	805	62	1.39	0.46
SPW 125-S	29 x 150	126	62	565	905	61	1.74	0.56
SPW 150-S	24 x 120	152	57	690	1120	61	2.13	0.66
SPW 175-S	21 x 110	174	52	770	1265	61	2.44	0.77
SPW 200-S	18 x 90	203	50	945	1495	60	2.89	0.90
SPW 250-S	14 x 70	260	42	1120	1870	61	3.67	1.14
SPW 300-S	12 x 64	302	40	1060	1995	61	4.00	1.30

## MINIMESH® HIFLO-S – HIGH PERFORMANCE FILTER WEAVE.

### HIFLO – High Flow Filter Weave.

MINIMESH® HIFLO-S filter weave -corresponds to the pore size range of the MINIMESH® SPW-S. By utilising very fine wires woven in plain weave, a high number of pores per unit area is achieved. This allows a very high throughput rate with small pore sizes. The MINIMESH® HIFLO-S filter weave is a surface filter, which means the smallest pore is determined by the distance between the weft wires and not by the pores within the three dimensional filter weave. Cleaning, back-flushing and strength are similar to the MINIMESH® SPW-S filter weave. As a rule, MINIMESH® HIFLO-S is used for filtration jobs that require high throughput rates with low filter medium contamination levels.

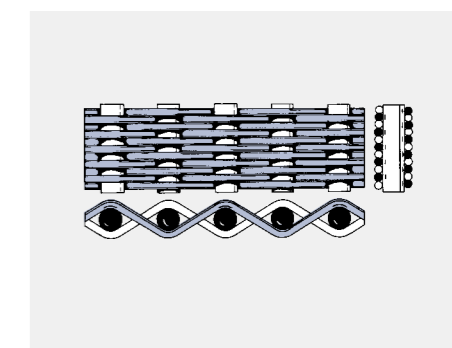
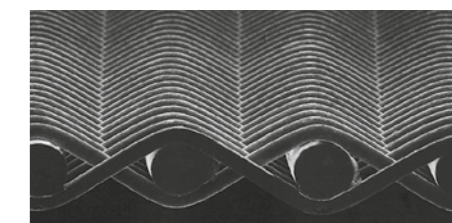
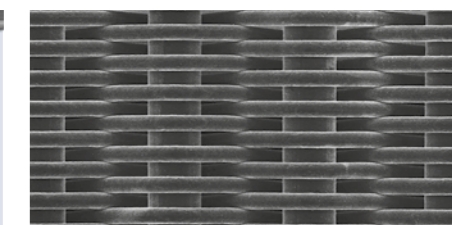
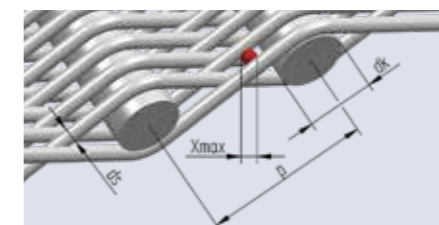

Notes on the HIFLO-S table:  
Column 3: largest geometrical determined pore size, tolerance ± 5% (AVIF-Project A224, A251)

1	2	3	4	5		6	7	8
Type of weave	MESH	Geometric pore size µm	Pressure drop-coefficient ζ	Tensile strength warp N/cm	Tensile strength weft N/cm	Porosity theor. %	Weight kg/m <sup>2</sup>	Cloth thickness mm
HIFLO 15-S	230 x 1650	15	345	100	120	63	0.20	0.07
HIFLO 20-S	175 x 1250	20	240	105	155	63	0.24	0.08
HIFLO 25-S	142 x 1020	25	200	125	180	63	0.30	0.10
HIFLO 30-S	117 x 840	30	170	145	210	63	0.36	0.12
HIFLO 35-S	80 x 700	35	120	285	250	63	0.53	0.18
HIFLO 40-S	88 x 640	40	125	185	270	63	0.48	0.16

## MINIMESH® DTW-S – DUTCH TWILLED WEAVE.

### DTW – Dutch Twilled Weave. Twilled weave.

Our MINIMESH® DTW-S twilled filter weave has weft wires woven as closely as possible in the classic 2/2 twilled weave. The very thin weft wires allow good flow-through properties with very small pore sizes. The MINIMESH® DTW-S filter weave is thicker and more stable than the MINIMESH® HIFLO-S filter weave and is characterised by good workability and very compact pore distribution. MINIMESH® DTW-S is a surface filter where the filtered material in most cases accumulates as a filter cake on the mesh surface. MINIMESH® DTW-S filter weaves reach a precise separation efficiency and are suitable as a distribution medium due to the high wettability.

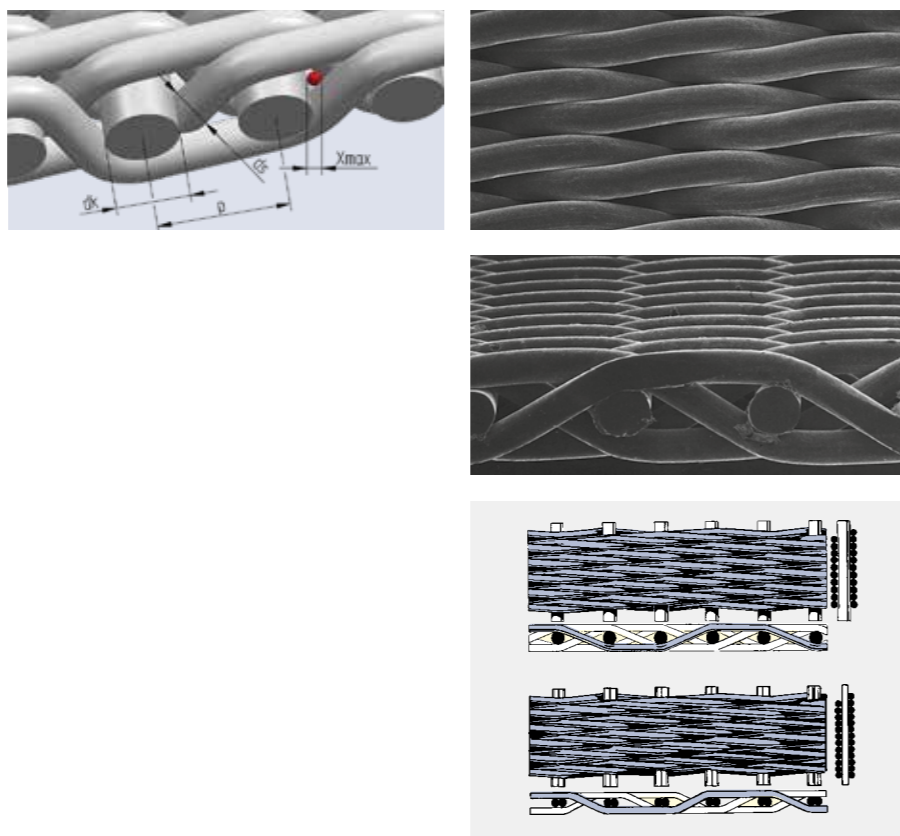

Notes on the DTW-S table:  
Column 3: largest geometrical determined pore size, tolerance ± 5% (AVIF-Project A224, A251)

1	2	3	4	5		6	7	8
Type of weave	MESH	Geometric pore size $\mu\text{m}$	Pressure drop-coefficient $\zeta$	Tensile strength warp N/cm	Tensile strength weft N/cm	Porosity theor. %	Weight $\text{kg/m}^2$	Cloth thickness mm
DTW 7-S	425 x 2800	7	2970	100	245	34	0.33	0.06
DTW 8-S	375 x 2300	8	3800	150	220	33	0.45	0.09
DTW 9-S	240 x 1600	9	4830	300	290	31	0.76	0.14
DTW 10-S	325 x 2300	10	2370	160	225	34	0.45	0.09
DTW 14-S	200 x 1400	14	1500	225	450	34	0.75	0.14
DTW 20-S	165 x 1400	20	800	185	465	40	0.69	0.15
DTW 21-S	165 x 1100	21	1220	190	565	36	0.84	0.17
DTW 45-S	80 x 700	46	330	190	790	46	1.15	0.27
DTW 90-S	40 x 560	88	300	235	1080	48	1.51	0.37
DTW 95-S	35 x 500	94	400	170	1325	47	1.70	0.41
DTW 120-S	30 x 360	121	260	440	1850	45	2.55	0.59

## MINIMESH® BMT/BMT-ZZ-S – BROAD MESH TWILLED DUTCH WEAVE.

### BMT/BMT-ZZ – Broad Mesh Twilled Dutch Weave.

MINIMESH® BMT-S filter weave is a special type of 2/2 twilled Dutch weave where the weft wires are not close to each other, as is the case with the MINIMESH® DTW-S, but instead are woven at a defined distance from each other. This allows specific customer requirements for a surface filter to be accurately met. Haver & Boecker recommends the MINIMESH® BMT-S filter weave in zigzag design, which provides the greatest possible mesh stability. MINIMESH® BMT-S is characterised by its high throughput and economy.

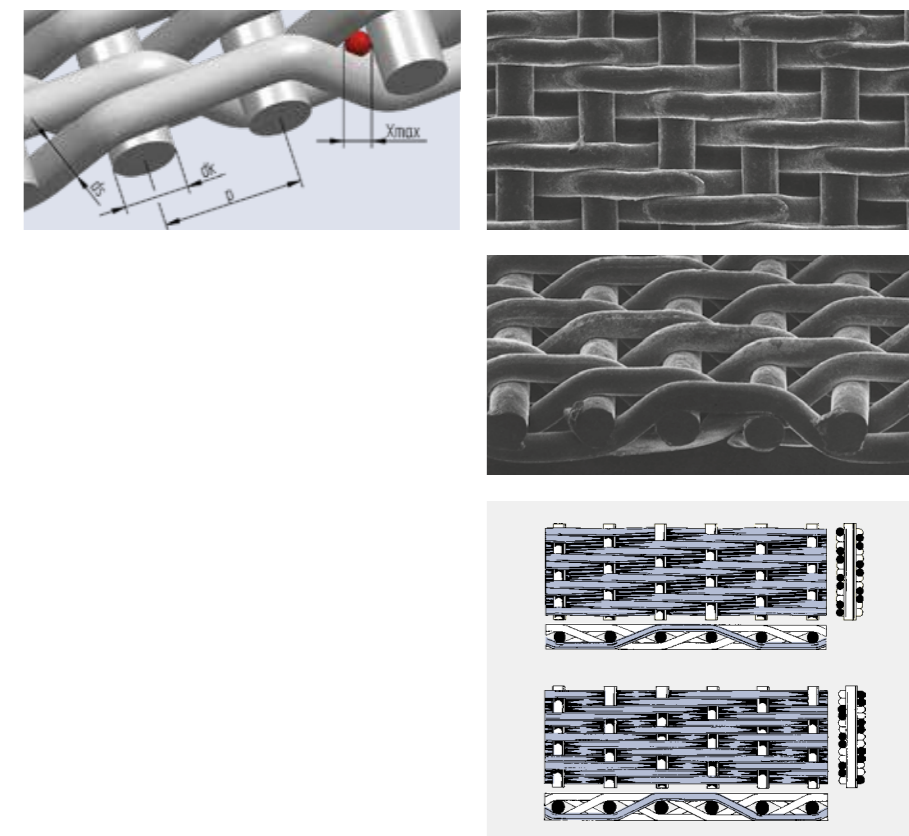

Notes on the BMT-S and BMT ZZ-S table:  
Column 3: largest geometrical determined pore size verified by glass bead test, tolerance ± 5%

1	2	3	4	5		6	7	8
Type of weave	MESH	Geometric pore size $\mu\text{m}$	Pressure drop-coefficient $\zeta$	Tensile strength warp N/cm	Tensile strength weft N/cm	Porosity theor. %	Weight $\text{kg/m}^2$	Cloth thickness mm
BMT ZZ 13-S	325 x 1900	13	1210	155	195	41	0.41	0.09
BMT ZZ 14-S	325 x 1600	14	1030	165	280	40	0.43	0.09
BMT ZZ 16-S	260 x 1250	16	1050	170	360	40	0.58	0.12
BMT ZZ 27-S	200 x 900	27	430	200	395	47	0.63	0.15
BMT ZZ 39-S	165 x 800	39	300	190	360	49	0.69	0.17
BMT ZZ 41-S	200 x 600	41	160	185	210	62	0.46	0.15
BMT 45-S	120 x 600	45	170	350	395	51	0.89	0.23
BMT 55-S	120 x 400	55	90	270	320	60	0.72	0.23

## MINIMESH® RPD-S – REVERSE PLAIN DUTCH WEAVE.

### RPD – Reverse Plain Dutch Weave.

Like the MINIMESH® SPW-S, the MINIMESH® RPD-S Reverse Plain Dutch Weave is a plain weave filter mesh, but has a reversed wire diameter arrangement. Thin warp wires are positioned close to each other and the thicker weft wire is woven in at a defined distance. The resulting higher strength in the warp direction makes MINIMESH® RPD-S popular for use as a filter belt. Moreover this versatile reverse plain Dutch weave is used in applications requiring specific acoustic properties, mechanical robustness and high throughput for filtration.

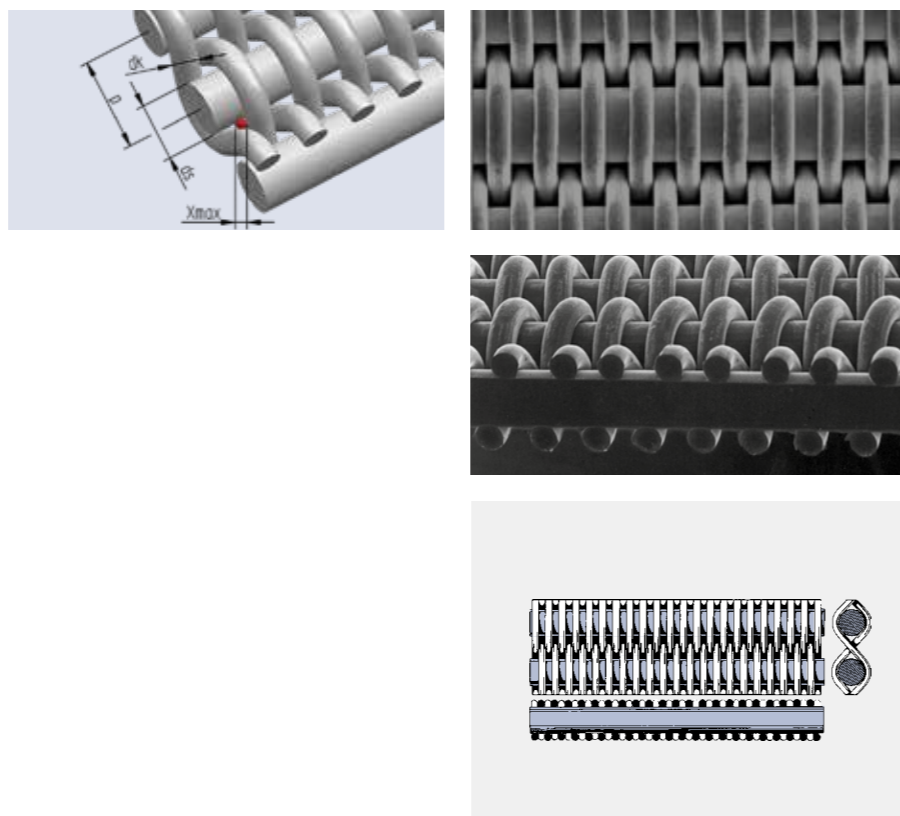

Notes on the RPD-S table:  
Column 3: largest geometrical determined pore size verified by glass bead test, tolerance ± 5%

1	2	3	4	5		6	7	8
Type of weave	MESH	Geometric pore size $\mu\text{m}$	Pressure drop-coefficient $\zeta$	Tensile strength warp N/cm	weft N/cm	Porosity theor. %	Weight $\text{kg/m}^2$	Cloth thickness mm
RPD 20-S	645 x 130	20	600	200	500	50	0.81	0.20
RPD 40-S	324 x 75	40	250	350	715	52	1.35	0.35
RPD 60-S	218 x 52	65	130	510	810	54	1.75	0.47
RPD 90-S	174 x 45	90	80	640	680	59	1.75	0.52
RPD 125-S	132 x 35	125	65	845	760	59	2.25	0.68
RPD 150-S	106 x 28	150	55	1120	880	59	2.62	0.81
RPD 175-S	89 x 24	175	50	1300	1000	59	3.15	0.96
RPD 200-S	89 x 22	200	42	1400	750	61	3.00	0.96

## MINIMESH® TRD-S – TWILLED REVERSE DUTCH WEAVE.

### TRD – Twilled Reverse Plain Dutch Weave.

MINIMESH® TRD-S twilled reverse plain Dutch weave is comparable to the reverse plain Dutch weave, however the warp wire is woven in a 2/2 twilled weave. This gives the advantage of not distorting the warp wire as much as in the plain weave. The resulting high strength in the warp direction favours applications such as a filtration belt.

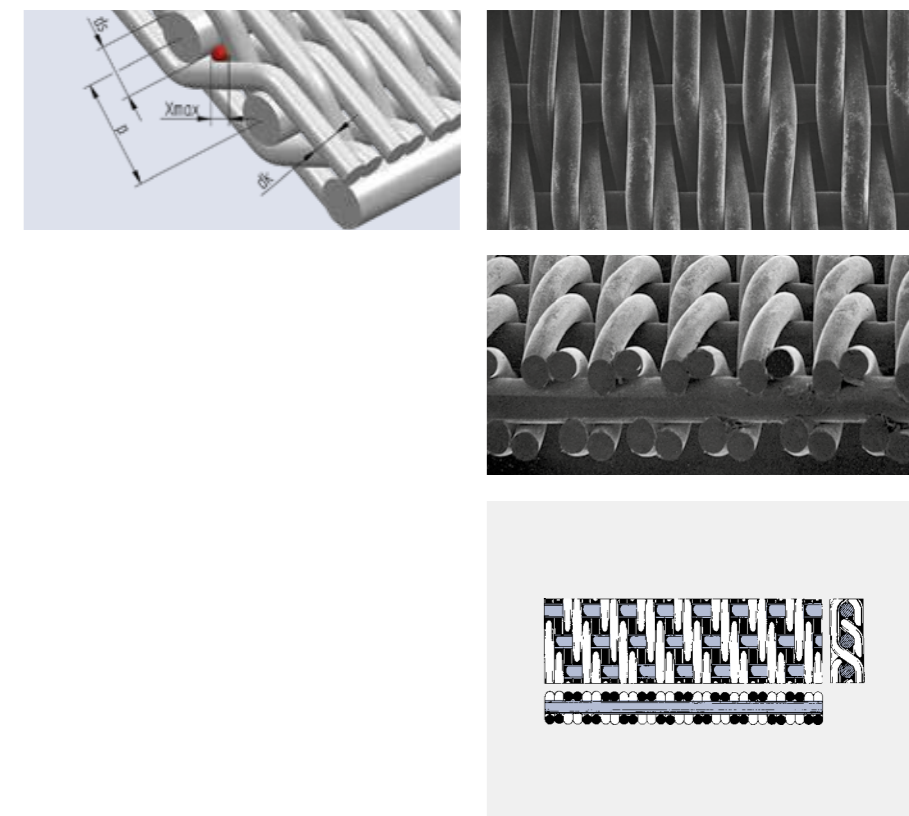

Notes on the TRD-S table:  
Column 3: largest geometrical determined pore size verified by glass bead test, tolerance ± 5%

1	2	3	4	5		6	7	8
Type of weave	MESH	Geometric pore size $\mu\text{m}$	Pressure drop-coefficient $\zeta$	Tensile strength warp N/cm	weft N/cm	Porosity theor. %	Weight $\text{kg/m}^2$	Cloth thickness mm
TRD 75-S	400 x 125	75	80	330	275	61	0.78	0.26
TRD 115-S	320 x 38	115	110	1445	640	52	2.66	0.70
TRD 260-S	132 x 18	263	60	5815	530	57	4.45	1.31
TRD 320-S	132 x 17	319	35	2575	765	58	4.08	1.24

# SELECTING THE APPROPRIATE FILTER MEDIUM.

If the wire cloth is used as a surface filter, then the following design data is necessary for selecting the optimum type of woven wire cloth:

**Fluid properties:**

- Process temperature
- Density  $\rho$
- Kinematic viscosity  $\nu$

**Flow properties:**

- Volumetric flowrate  $\dot{V}$
- Flow area  $A$
- Maximum pressure drop  $\Delta p$

**Particle properties:**

- Particle size/particle size distribution
- Particle cut size

This data allows the permeability and geometric pore diameter to be determined. The characteristic values allow the selection of the appropriate woven wire cloth – in accordance with the required application and the material requirement.

