

Twin Twister



**SARTORI**
AMUSEMENT RIDES

Rides manufacturers since 1957

Twin Twister



Park Model



On trailer

TECHNICAL SPECIFICATIONS

Base Size: ~ 23 x 9.5 m - 75.4 x 31.1 ft

Height: ~ 18 m - 59 ft

Vehicles: 2

Seats: 14 seats each gondola

Th. Seats: 28 seats

Th. Capacity: ~ 600 passengers/h

Speed: ~ 7- 8 rpm

Lighting: ~ 5 kW

Moving Power: ~ 95 kW

EN-7/23-rev.2.0 – Subject to technical changes as part of product development, as well as errors and omissions.



MAJOR

TECHNICAL SPECIFICATIONS

Structure



ON TRAILER

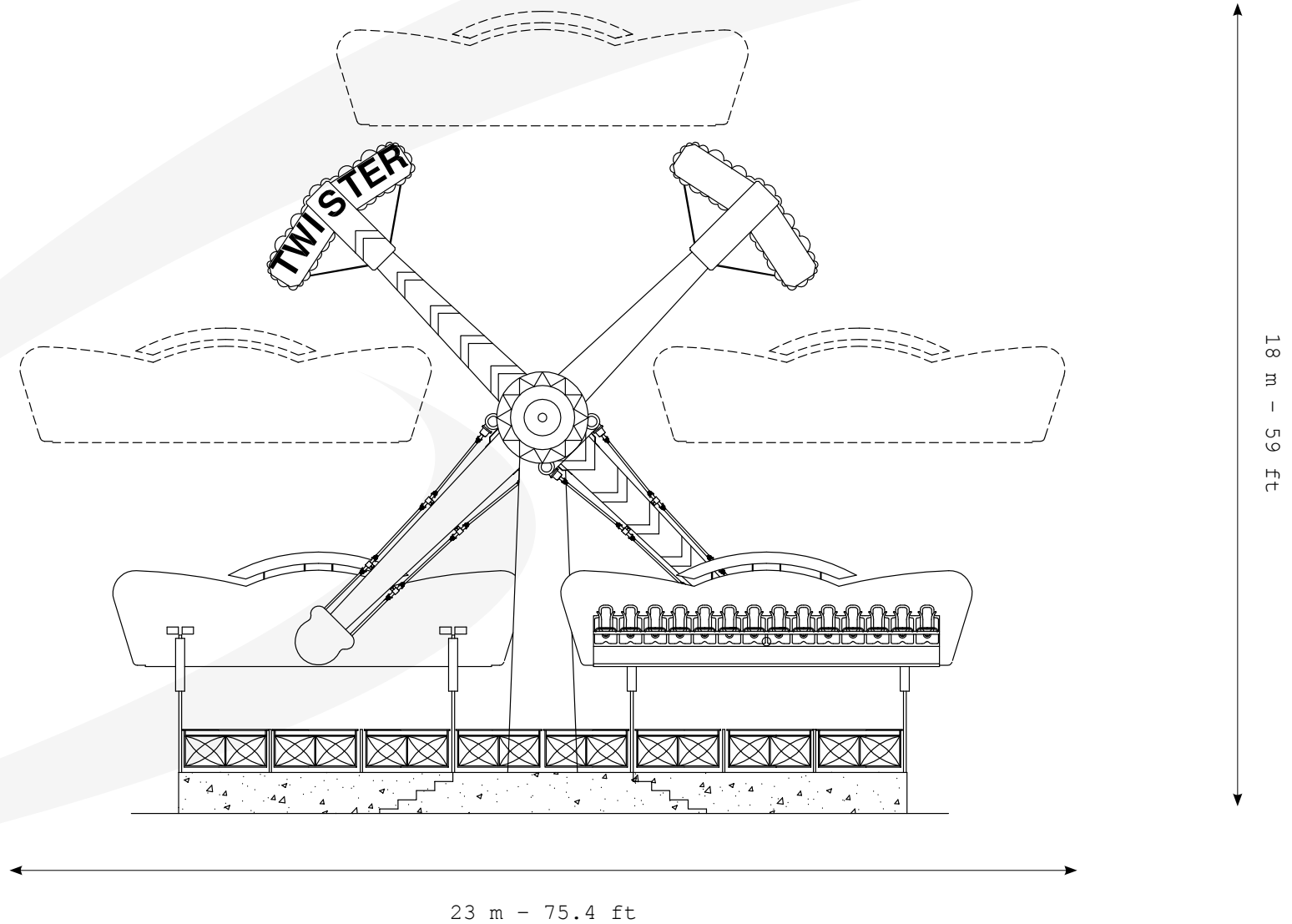

TECHNICAL SPECIFICATIONS

Structure



ON TRAILER

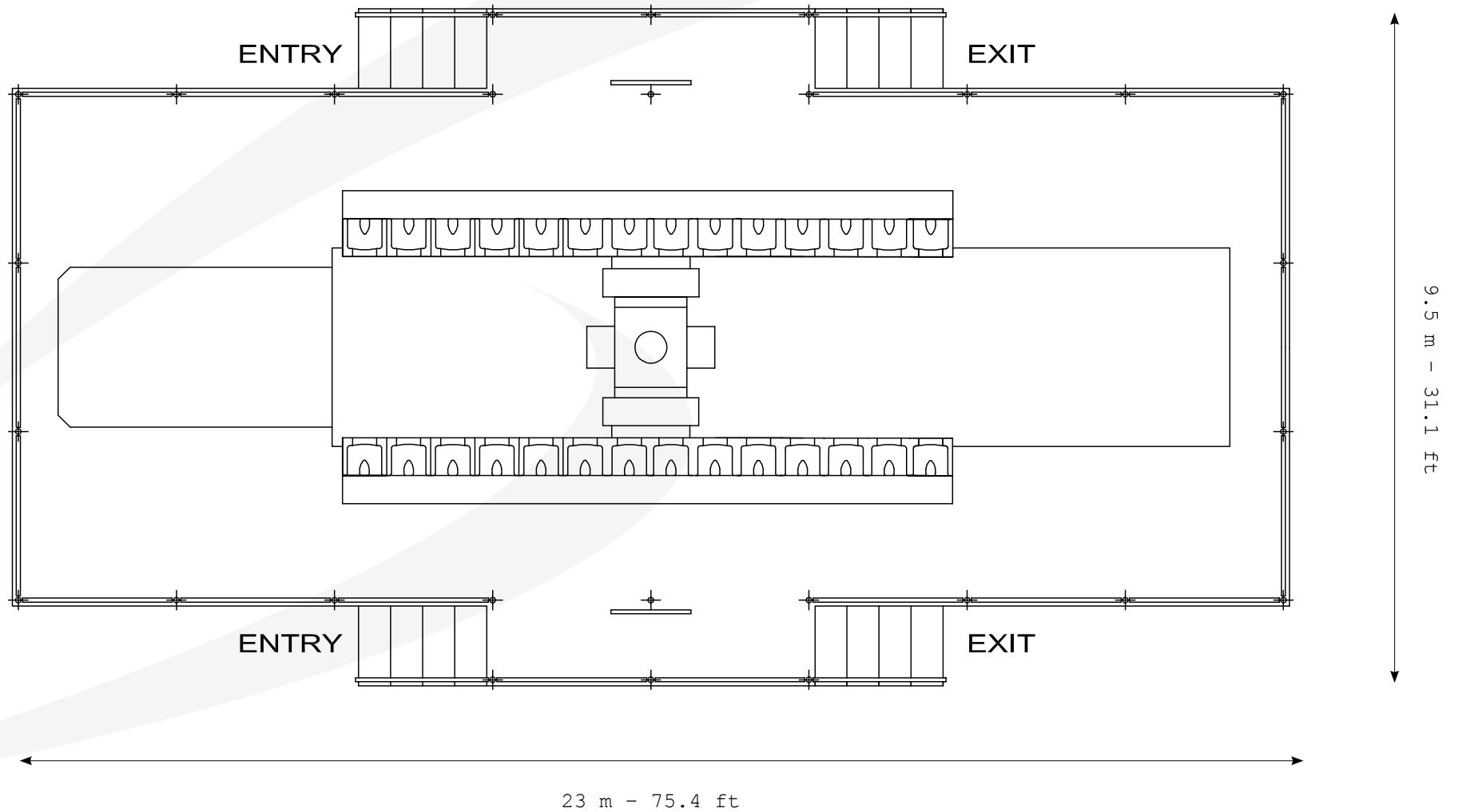

TECHNICAL SPECIFICATIONS

Structure



ON TRAILER

WIDTH 2.55m - 8.36ft

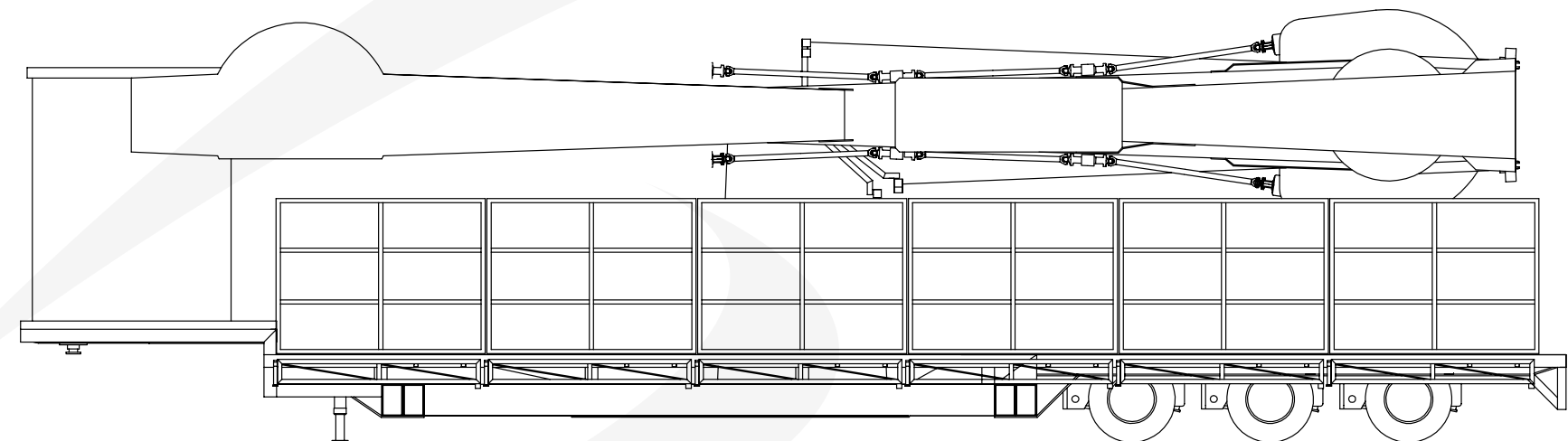

4.1 m - 13.4 ft

14.6 m - 47.9 ft



ON TRAILER



SARTORI
AMUSEMENT RIDES



ON TRAILER



SARTORI
AMUSEMENT RIDES



ON TRAILER



SAVED
AMUSEMENT RIDES



ON TRAILER

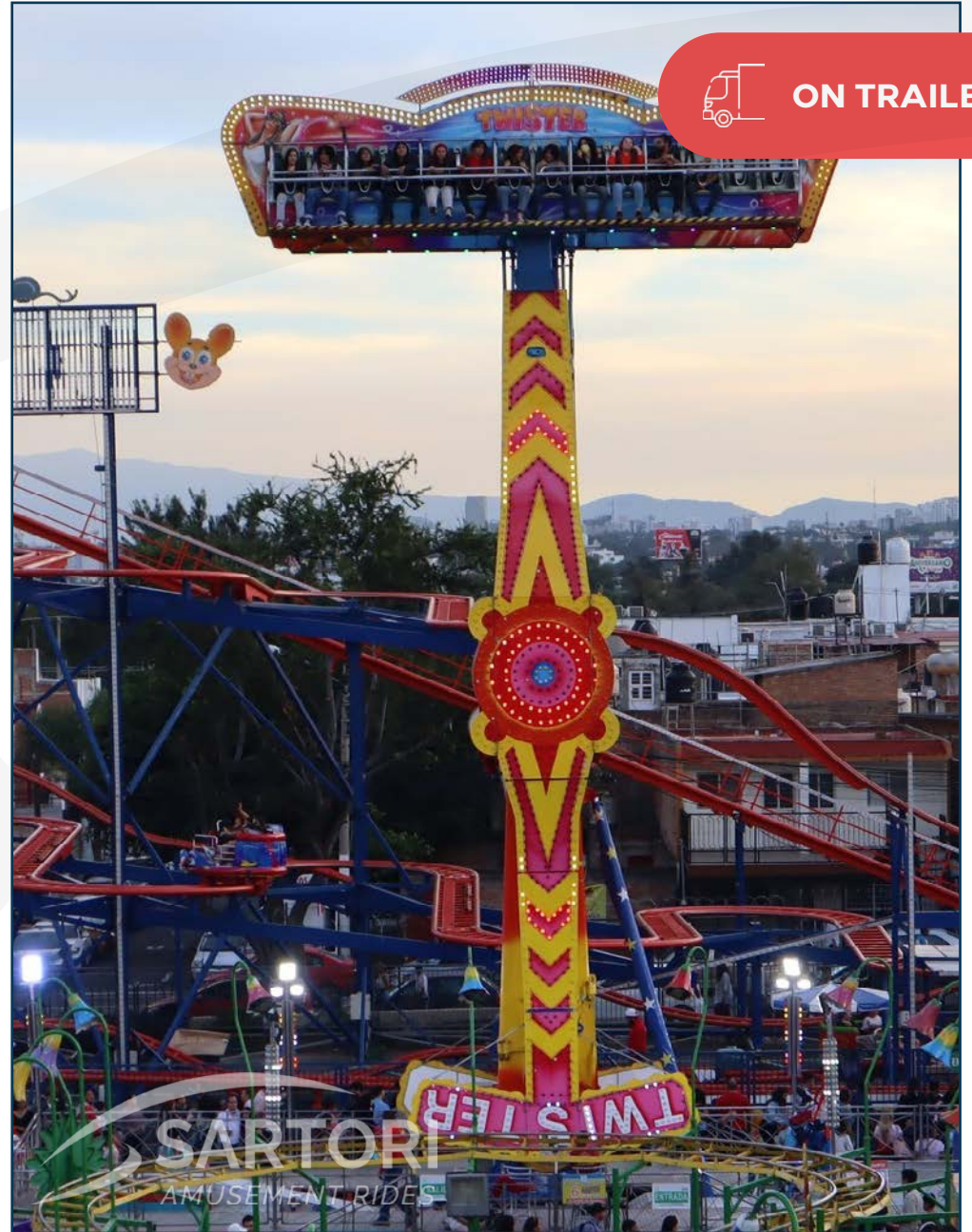

 ON TRAILER

