

Expeditionary Energy & Sustainment Systems (E2S2)



Mr. Cory Goetz
Chief Engineer

Controlled by: US Army
Controlled by: PEO CS&CSS
Distribution Statement: A
POC: cory.r.goetz.civ@army.mil

E2S2 Leadership

MISSION

Provide integrated, scalable, and affordable expeditionary energy, force sustainment, and contingency basing capabilities that reduce sustainment demand for Warfighters across the range of Joint ops.

VISION

Serve as the DoD lead for globally responsive operational energy and contingency basing solutions to enhance Warfighter capability.



Project Manager

COL Laverne Amara



Deputy Project Manager

Victor Hernandez



Product Lead Large Power Systems

Bob Thoens



Product Manager Mobile Electric Power Systems

LTC Thomas Beyerl



Product Manager Force Sustainment Systems

LTC Daniel O'Neill



Operations Branch Chief

George Lembrick



Business Management Division Chief

Michael Allen



Logistic Management Division Chief

Jon Buonerba



Technical Management Division Chief

Cory Goetz



Power Generation and Distribution

Large Tactical Power Systems (500kw)



Medium Power Systems (5-60kw)



Advanced Medium Mobile Power Sources (AMMPS)

Microgrid (120-360kw)



Small Power (>5kw)

Platoon Power Generator (PPG)



Small Tactical Electric Power (STEP)



Sustainment Systems

Cargo Air Delivery

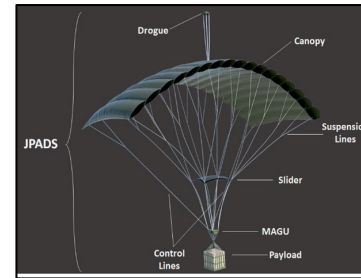

Joint Precision Air Drop System (JPADS)
2,000lbs and 10,000lbs

Camouflage and Concealment



Ultra Lightweight Camouflage Net System (ULCANS)

Force Provider Expeditionary Modules



ESWDS



Large Tactical Power Systems (LTPS)



Description:

- The next generation of LTPS will provide increased system efficiency, reliability, mobility and maintainability.
- 500kW MIL-STD generator (480V, 50/60Hz)
- 50°F to 135°F (-45°C to 57°C)
- NBC contamination survivability
- Ability to withstand high-altitude electromagnetic pulse
- Rated at altitude (4000ft/1220 m)
- Parallel capable
- US Army LTPS Solution will be mounted to M870 Trailer
 - 2 x 500 kW Power Generators
 - Power Distribution Unit (PDU), Cable Distribution system, Trailer interface kit
 - Key Characteristics (approximations)
 - Weight of Power Unit (less trailer) – 48,000 pounds (22,000lbs per generator + 4,000lbs cables, PDU, mounting)
 - Height – 11.7 ft (3.56 m); (Power Unit on skid approx. 8 ft (2.44 m))
 - Length – 41 ft (12.5 m)
 - Width - 8.3 ft (2.53 m)

Availability

- Fielding FY26, export FY27
- Development currently ongoing
- Procurement contract in pre-award stage

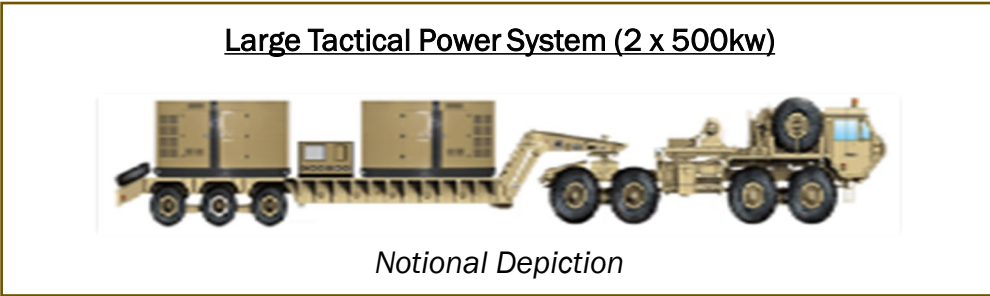

LTPS will provide increased system efficiency, reliability, mobility and maintainability

AMMPS Family of Systems



• Description

- Multi-fuel (JP-8, JP-4, DF-1, DF-2, DF-A)
- 50°F to 135°F (-45°C to 57°C)
- NBC contamination survivability
- Ability to withstand high-altitude electromagnetic pulse
- Rated at altitude (4000ft/1220 m)
- Parallel capable
- Microgrid capable
- Low Velocity Air Drop (LVAD) capable
- Overload capability
- Battle short mode



• Availability

- Fielded since 2010
- Procurement contract recently awarded

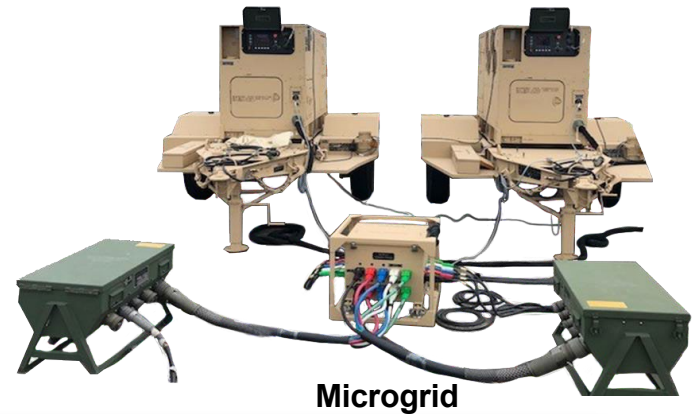

AMMPS provides scalable solutions with a common user interface

AMMPS Microgrid



30kW / 60kW AMMPS Generators
Trailers removed for clarity

Advanced DCS
Adds Microgrid software & network port to allow communication between generators sets

PCI Box
Consolidates parallel and network signals into single cable

Microgrid Feeder Box
Enables load sharing & provides contactor protection for idle

Ring Bus Cables
Connects Microgrid feeder boxes, forming a single distribution hub for all loads

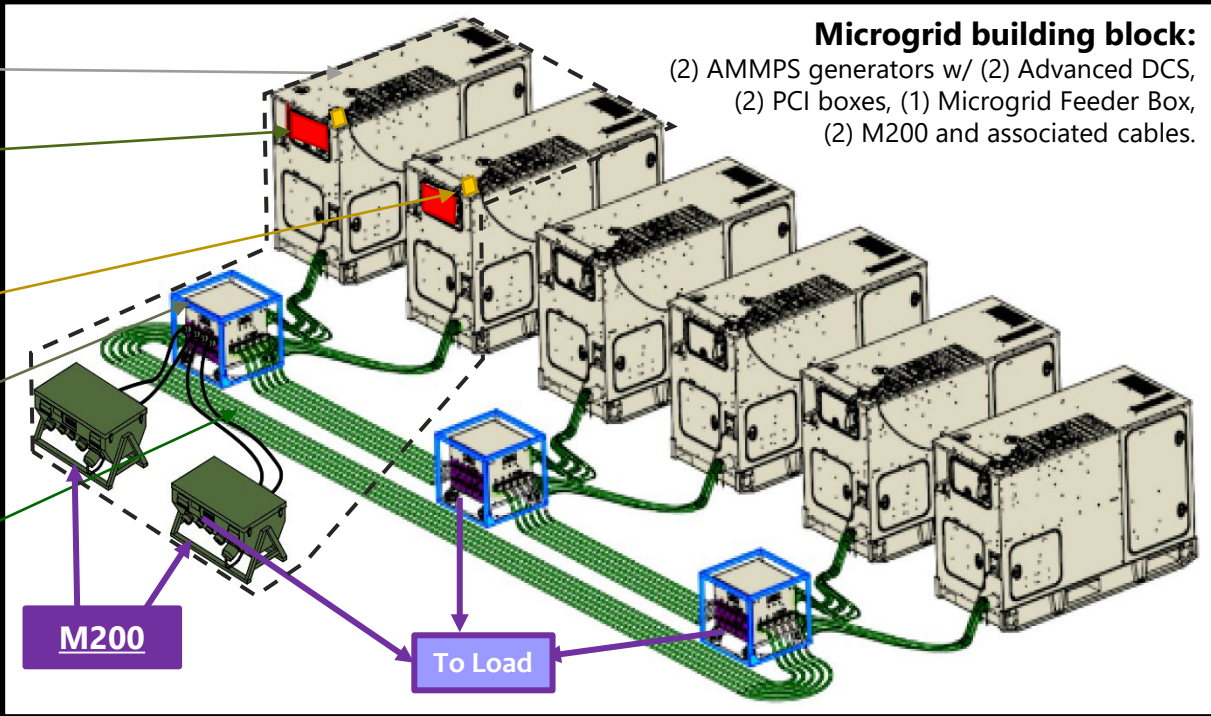

Microgrid building block:
(2) AMMPS generators w/ (2) Advanced DCS,
(2) PCI boxes, (1) Microgrid Feeder Box,
(2) M200 and associated cables.



- 20-30% fuel savings reducing resupply
- 74% reduction in generator operating hours reducing O&S costs
 - Reduced wear
 - Reduced maintenance
 - Reduced log package

LEGEND: AMMPS – Advanced Medium Mobile Power Sources; kW – Kilowatt; DCS – Digital Control System; PCI - Parallel Communications Interface
O&S – Operations and Support

All current production 30-60kW AMMPS generators are Microgrid capable

- **Description:**

- Modernize and standardize next generation of Army RWS by incorporating 30+ years of shelter performance technology and improved manufacturing for increased producibility and affordability
- Provide more modular shelters for increased interoperability and scalability
- Suitability in extreme environments for effectiveness around the globe
- Standard designs for sustainability and reduced life cycle costs

- **Availability:**

- Award Date TBD (est. this month MAR 2024)

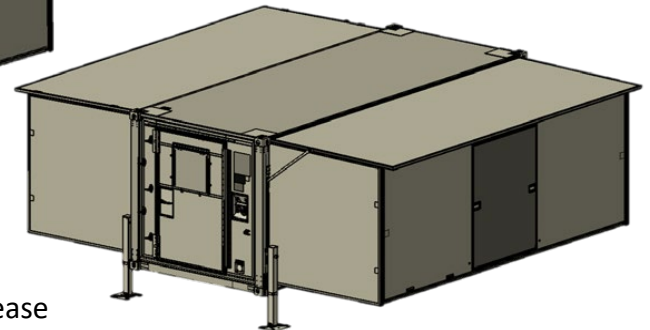
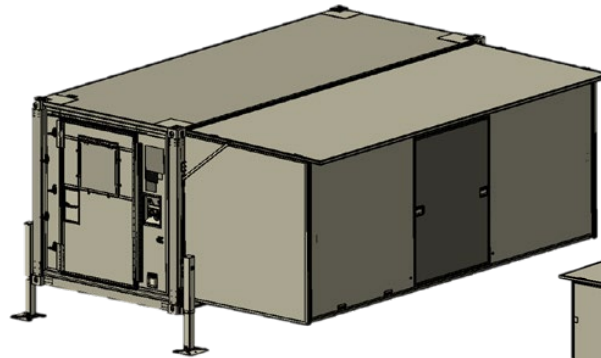
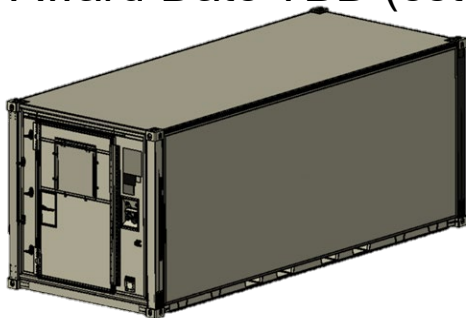

- **Description:**

- Provides operational units full protection/concealment against long-range precision fires, drones, ground, aerial, and satellite threats
- Restores combat overmatch against current enemy sensor threats
- Increases Soldier lethality and effectiveness while ensuring protection from modern battlefield threats
- Full Spectrum Signature Management. ULCANS Inc 1 provides concealment from all current battlefield sensor threats in a near peer MDO environment; Low-Cost Force Multiplier

- **Availability:**

- Contract Expires – 29 Mar 28. Export version available for procurement



- **Description:**

- Provides force projection to any location within 24-48 hours
- Highly mobile, rapidly deployable modular system that is easily sustainable
- Supports 150 personnel with:
 - Environmentally controlled billeting
 - Food Service
 - Hygiene
 - Power generation & distribution
 - Fuel & water storage
- Add-on kits include:
 - Shower Water Reuse System to reduce shower water consumption by 75%;
 - Cold Weather Kit allows operation to -15 deg F;
 - energy efficient shelter liners and doors, and solar shades
 - AMMPS micro grid components capable of reducing power consumption by 40%

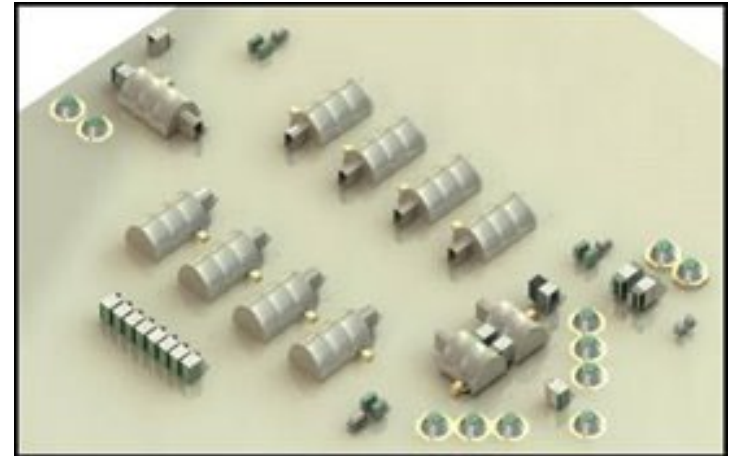

- **Availability:**

- Multiple contract vehicles available to procure FPE component systems

Expeditionary Shelter Protection System (ESPS)

- **Description:**

- Rapidly deployable shelter panel system
- Provides immediate ballistic protection up to 7.62 x 54mm threats and up to 82mm indirect threats with blast overpressure protection capabilities
- Can be erected and struck around a 20' x32' (6m x 10m) shelter in approximately 1 hour with a 4-person team
- Available soft wall and rigid wall shelter options
- Lightweight, re-deployable, reusable that requires no material handling equipment or special tools

- **Availability:**

- Contract Expires – 20 Dec 28



- **Description:**

- Reduces use of burn pits by providing a cleaner solution for onsite disposal of solid waste (1000lbs per day (450kg))
- Reduces Soldier, civilian, and local population exposure to pollutants from open air burn pits and associated spread of illness from solid waste
- Reduces amount of trash that must be backhauled, reducing Soldiers' exposure and attacks during convoy operations
- Eliminates security risk from uncontrolled access to trash
- Deployable, small footprint
- Simple operation, minimal training. Requires no contractor support

- **Availability**

- Contract Expires – 12 Jul 26



Joint Precision Airdrop System 2,000 lbs. (JPADS 2K)

- **Description:**

- High altitude, high offset, precise aerial delivery for 2,000 (900kg) lbs. of equipment to Army and Special Forces formations. V3 configuration includes:
 - delivery during the daytime in GPS-denied environment
 - integration of radio communications
 - vision-based navigation
 - JPADS website mission planning capabilities
 - Advanced guidance, navigation and control software
- Planned V4 capability includes GPS-denied navigation during all times of day, in inclement weather

- **Availability:**

- Contract available through FY25



- **Description:**

- High altitude, high offset, GPS guided precision aerial delivery for 10,000 lbs. (4500kg) of equipment and/or resupply
- Delivers from release altitudes of 24,500 ft. (7,500m) MSL down to 5,000 ft.(1,500m) AGL
- Provides offset up to 25km (objective) from the target delivery within 250m.
- Suspended payload weight from 4,500 to 9,500 lbs. (2000-4300kg)
- Autonomous Guidance Unit (AGU) uses GPS to control the JPADS 10K parachute and steer payloads to programmed impact point

- **Availability**

- Contract available through FY25



- **Power Mobility:** Do current mobility demands call for greater use of and standardization of auxiliary power units on vehicles
- **Power Hybridization:** Key to power efficiency and reliability is addition of storage and power electronics
- **Soldier Power:** Technologies that will enable powering and battery recharging for the small and light dispersed unit
- **New Program - Division Mobile Medical Shelter:** The DMMS is a 22-bed system of shelters that enables Role 3 medical care far forward on the battlefield. This capability will support the Division as a Unit of Action
- **New Program - Autonomous Extended Range Aerial Delivery System (AERADS):** AERADS consists of numerous autonomous powered and unpowered logistic gliders currently in development to significantly extend the range of existing aerial delivery systems

**Emerging needs driven by increased need for mobility
and contested logistics environments**

Questions/Discussion

Expeditionary Tricon Self Service Laundry System (ETSSLS)

• Description:

- Provides capability for laundry service to 150 personnel
- 4 – High efficiency 21 lbs. front loading washing machines
- 4 – 18 lbs. light commercial dryers
- Onboard waste and supply pumps
- Environmentally controlled (cooling/heating)
- Setup: 45 min, 5 personnel
- System includes
 - Fresh and grey water storage
 - Hoses
 - Power Cables
- Interfaces to any base camp operation
- Capable of operating as standalone Unit
- Can support small expeditionary forces in austere environment
- Transportable
 - Land/Rail/Sea/Air
 - Meets CSC/ISO requirements
 - Weighs less than 10K lbs.
 - Forkliftable

• Availability:

- Contract Expires – 13 Aug 24

