



BR

International
Consulting
Services

Shaping military rail logistics in Europe

Speaker



Dominik Braun
CEO



Kenneth Carlson
Regional Manager



Josef Pöcher
Senior Transport Advisor



BR

International
Consulting
Services

Military Rail Logistics

Introduction



- All-in-one service provider for military rail logistics
- Rail and military experts all over Europe
- Operational area: countries in green

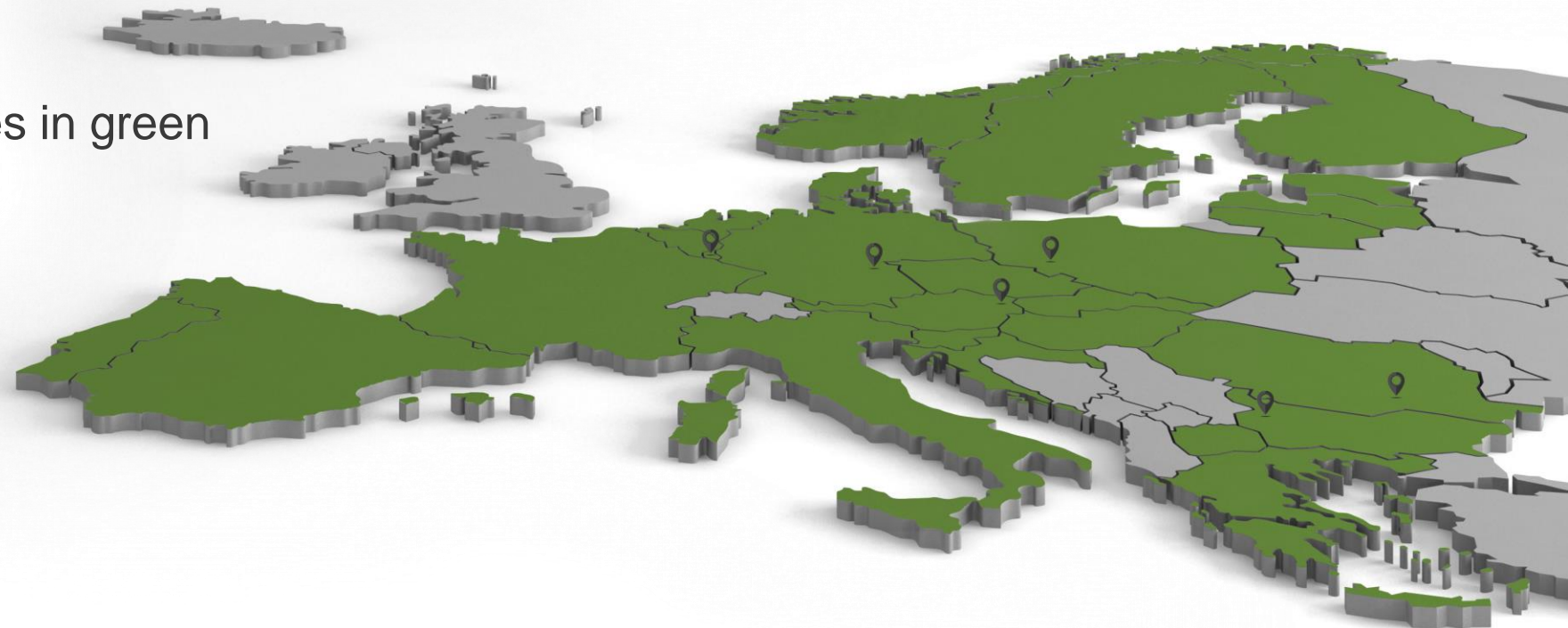

 Locations and accomplished missions

All-in-one



- Train planning and ordering based on the "unit list" (list of items to be transported)
- Calculating the demand for blocking, bracing & tie-down material (BB&T)
- Logistics and provision of BB&T material on the loading site
- Loading procedure incl. proper placement of the BB&T by our staff
- Transport to the final destination by RU
- Unloading procedure incl. removal of BB&T
- Management and storage of BB&T material



Train planning and ordering



Based on the unit list, we create the NATO Stanag lists under economical aspects:

- Matching the cargo with rail cars according to international rules and regulations
- Optimization of the utilization of freight wagons
- Calculation of the blocking, bracing & tie-down material (BB&T)



Guidelines

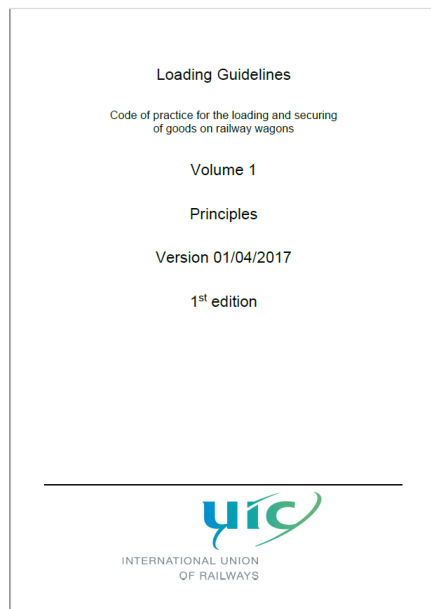

UIC Vol 1

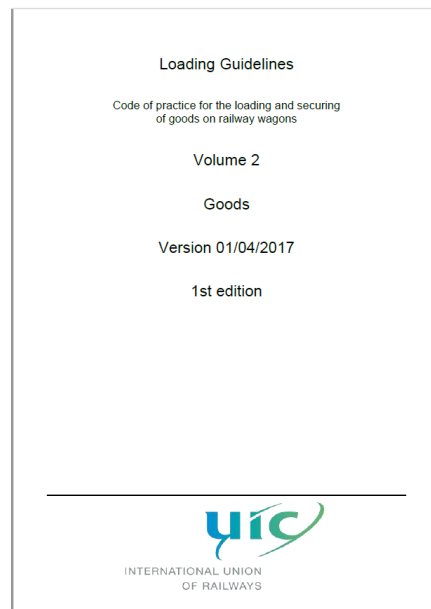

UIC Vol. 2

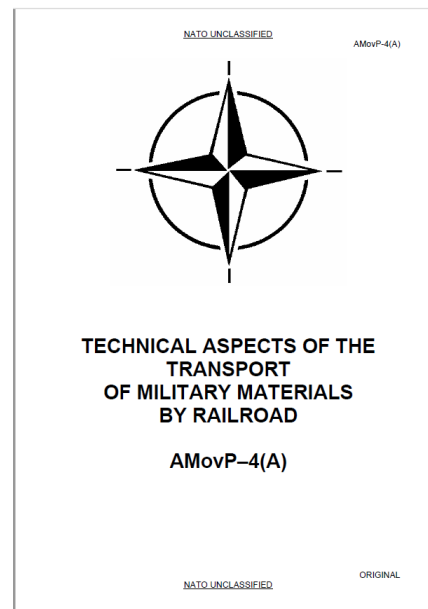

AMovP-4
(AMandTP-1)

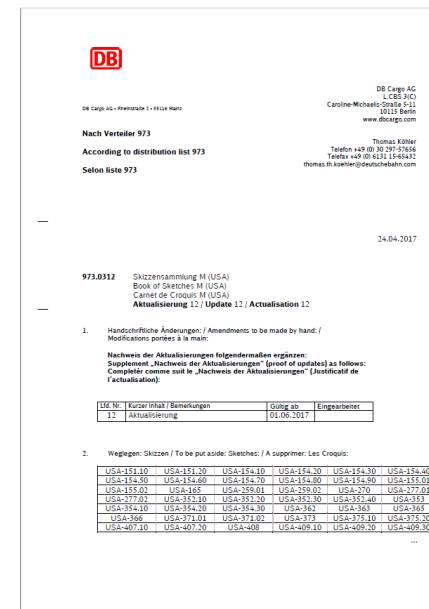

Book of
Sketches

Planning procedure

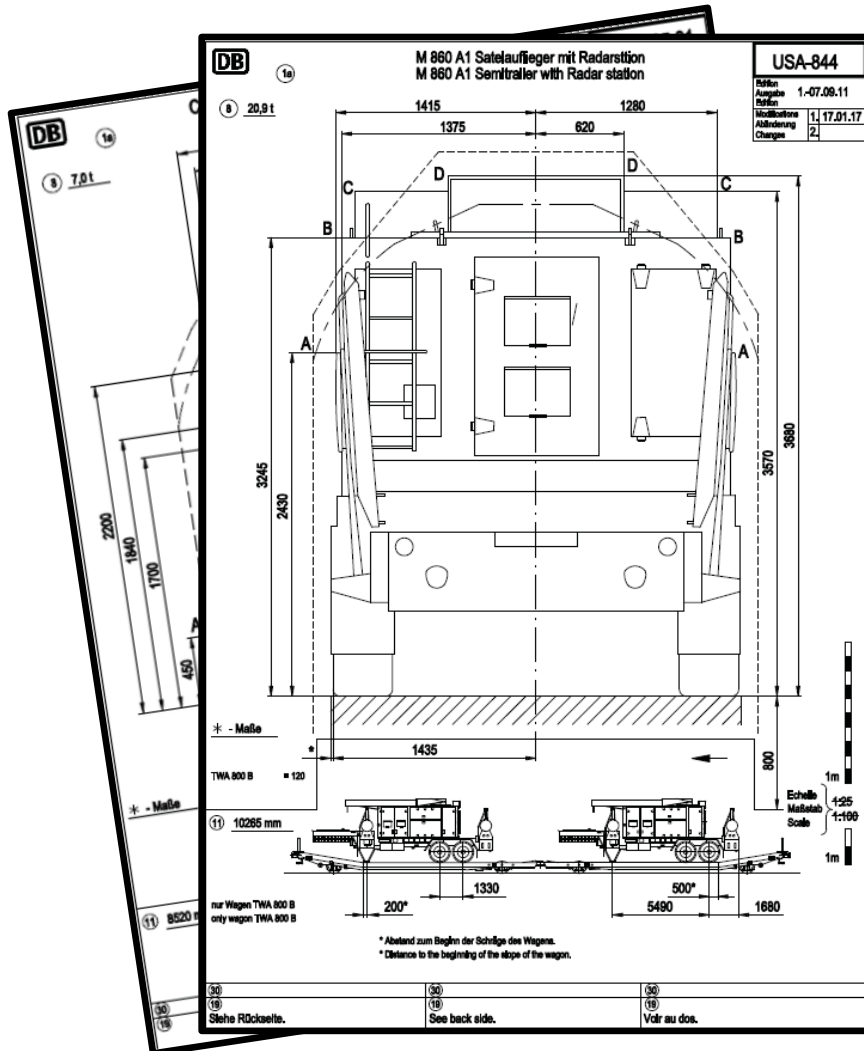

Trained teams experienced
in the application of the
Book of Sketches

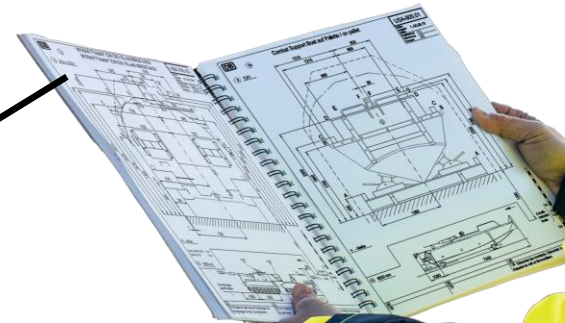



Logistics & preparations

Loading procedure



- Arrival on site, coordinate with all the parties involved
- Cross-check of the equipment being loaded
- Cross-check and preparation of the railcars. Ensuring all railcars are secured and ready for loading in cooperation with the Railway undertaking (RU) representative
- Preparation and rechecking of the BB&T material
- Loading the train under our supervision (positioning)
- Proper placement of the BB&T material by our staff
- If required, adaptations of the loading plan can be made on site with the RU representatives



Transportation by Railway Undertaking



- Safe and efficient transportation all over Europe
- Continual monitoring of all transports due to permanent communication with the responsible RU
- Immediate response in case of special incidents, fixing the problem directly on site, free of charge



Unloading procedure



- Preparation of the train
- Removal of BB&T material
- Ensure safe unload of vehicles off the train
- Quality check of all BB&T material
- Disposal or storage of BB&T material depending on quality check



Management and Storage of BB&T



- Stored in warehouses all over Europe
- Mandatory annual inspections being made
- Logistics and transports to and from the railheads is taken care of
- Quality check prior to every application
- Multiple usage of BB&T increases cost efficiency significantly



Additional services included



- Immediate response to emergencies along the route (e.g. after a wagon breakdown)
- Language support on site
- Coordination between the responsible entities in charge
- Consulting during the loading operation and rail inspector services (technical transfer inspection)



Research and Development

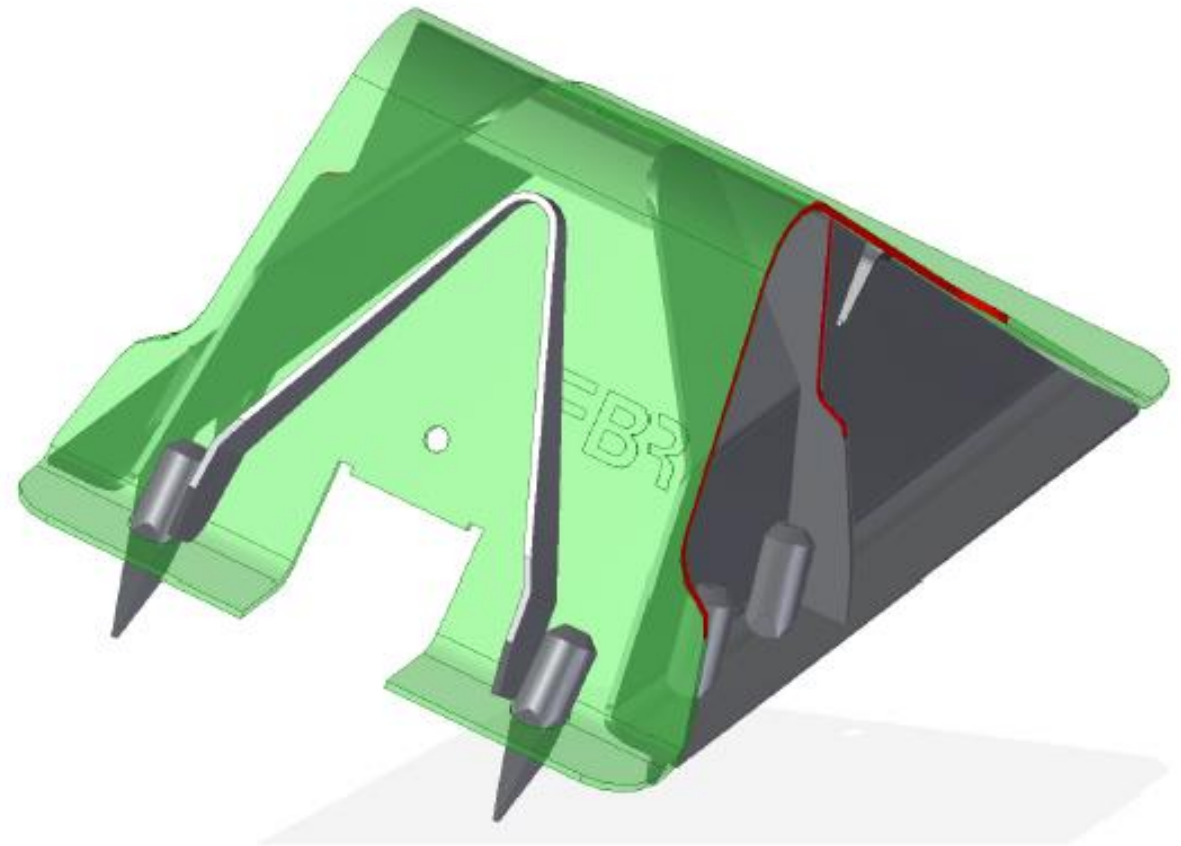
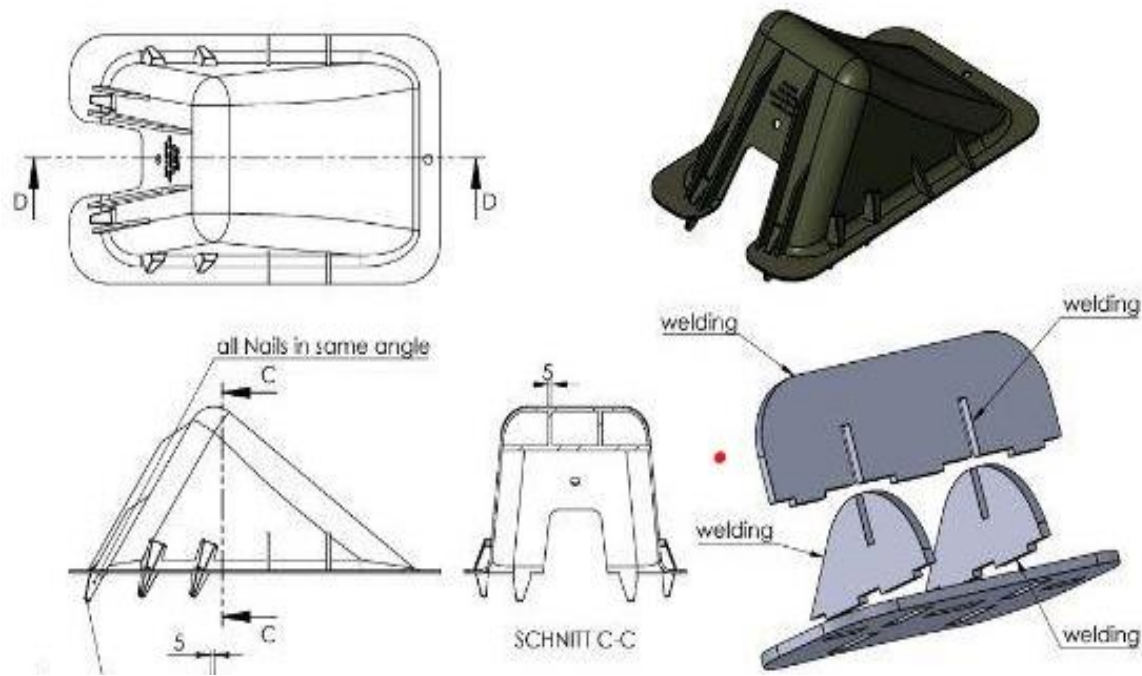

Assets



Experience

- Supporting NATO armies since 2017
- More than 2000 military rail transports accomplished

Collection of unique knowledge and manpower

- National railroad experts from all over Europe
- Former soldiers and military logistics specialists from
 - US Army
 - Polish Armed Forces
 - Belgium Armed Forces

All kinds of BB&T material to secure any cargo



Statistics



- More than 2000 military rail transports accomplished
- Success rate: 99,78%
 - The rest was fixed immediately, on the spot, free of charge and arrived in time
- Safety rate: 100%
Not a single major accident occurred

OPERATIONAL AREA

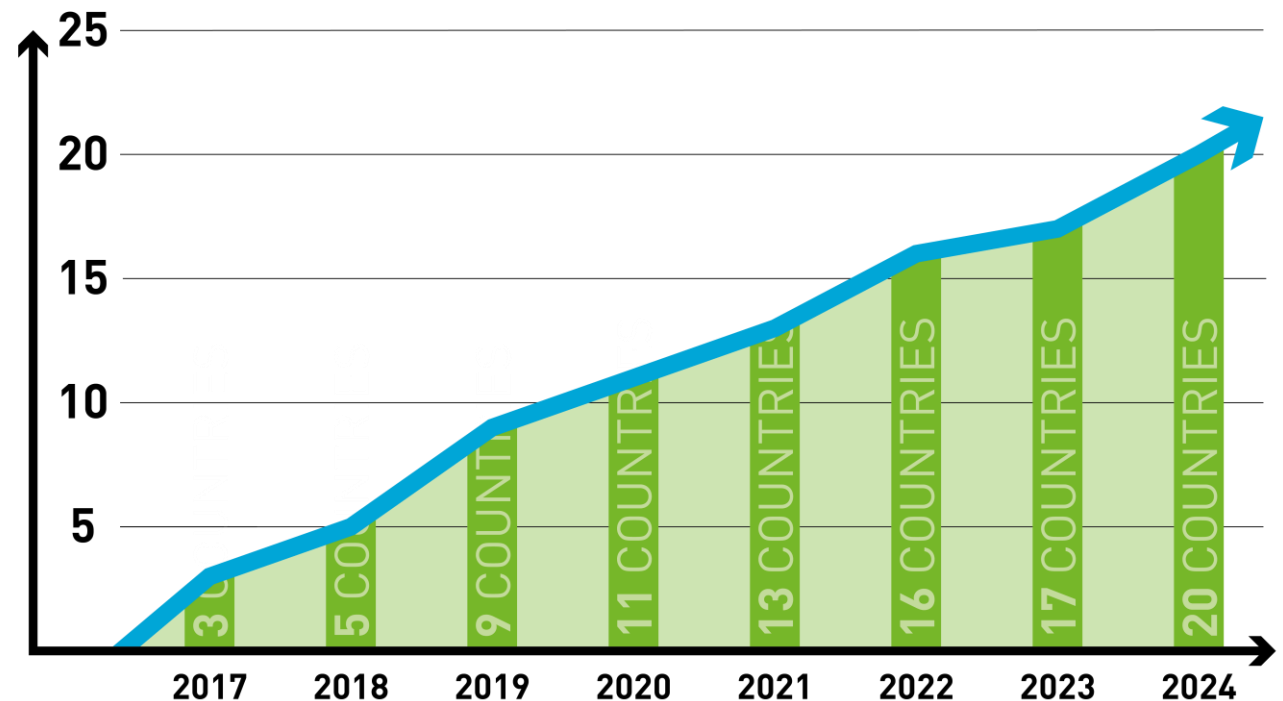

09.01.2017

Order overview

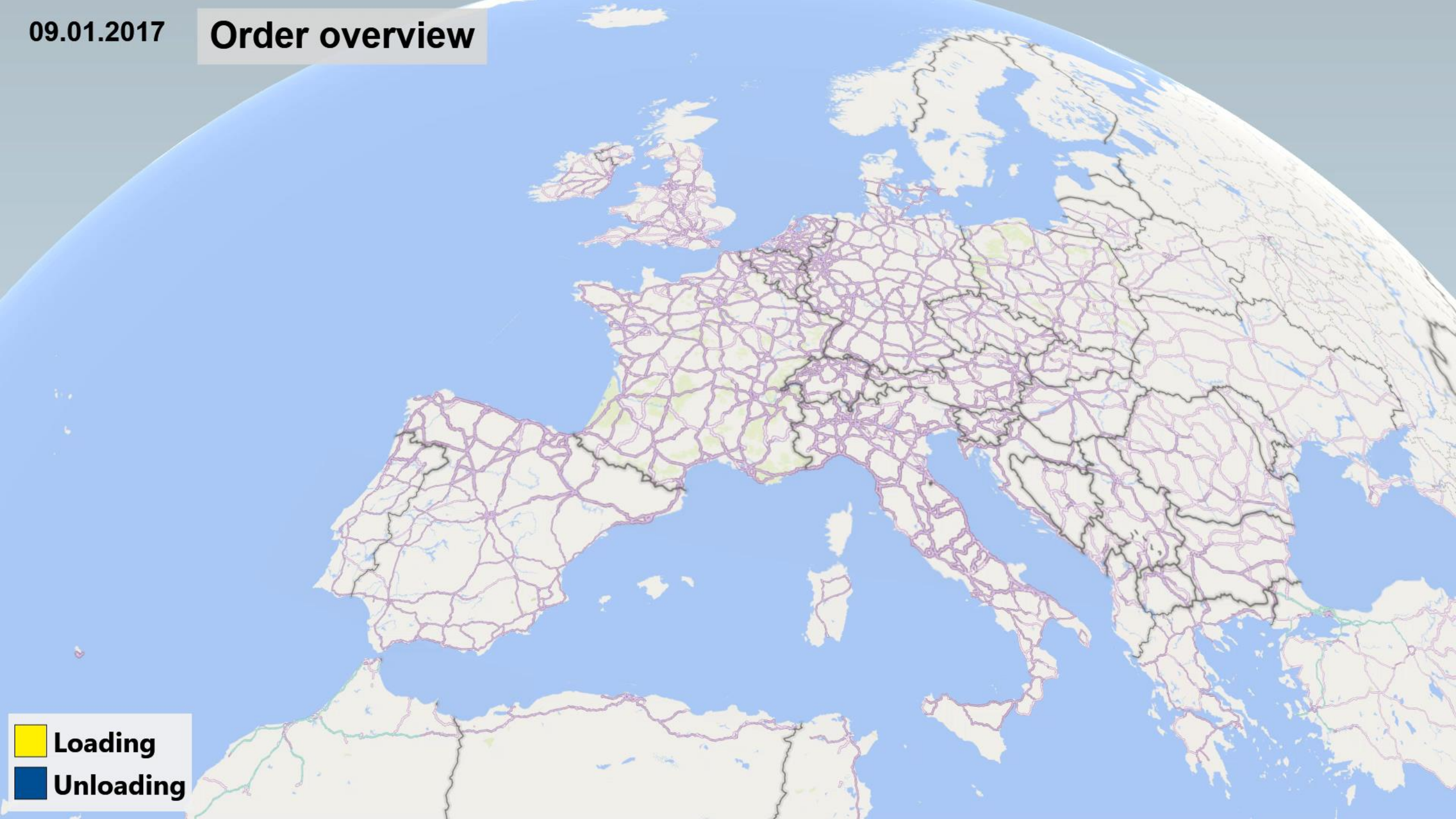

 Loading

 Unloading

References



▪ Satisfied Customers

In cooperation with DB, SNCF, RCH, LTG and Pol-Mare we have served the following armed forces:

- US Army
- British Army
- Forze armate italiane
- Hæren
- Magyar Honvédség
- Deutsche Bundeswehr
- Oružane snage Republike Hrvatske
- Nederlandse krijgsmacht
- Armée belge / Belgisch leger
- Lëtzebuerger Arméi



Certified quality



- ISO 9001:2015
(Quality Management)
- SCC**.:2011
(Occupational Health & Safety)
- SMS EU RL 2016/798
(Safety Management System)

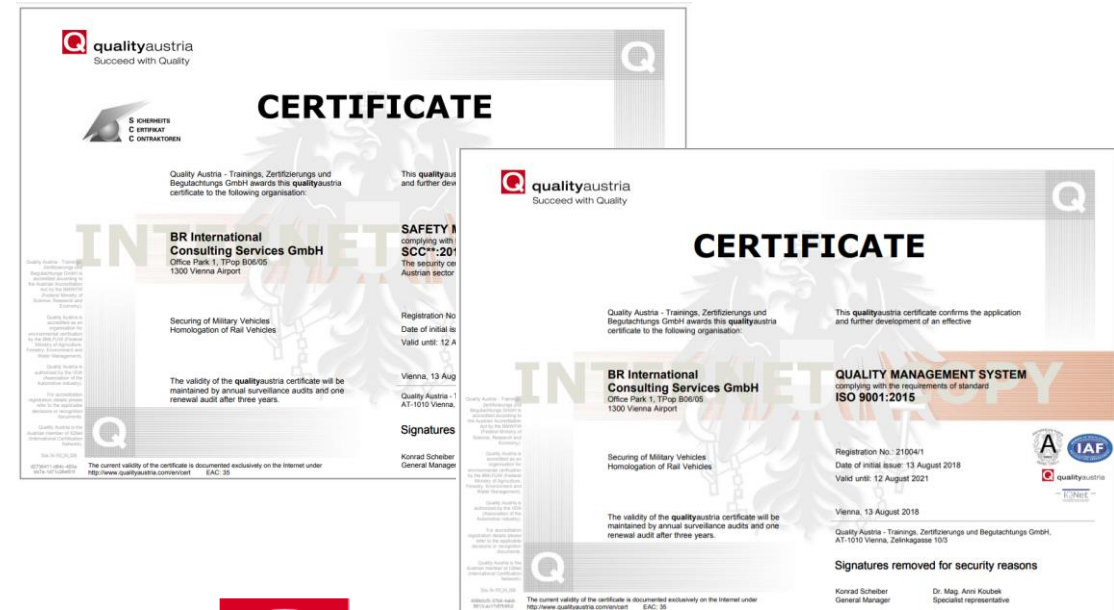

SYSTEM CERTIFIED

ISO 9001:2015 No.21004/1
SCC**.:2011 No.00245/1
SMS EU RL 2016/798 No.00043/0

Benefits for customers



- Smooth and efficient movement of military equipment throughout Europe
- All-in-one package
 - Planning
 - Loading
 - Transport
 - Unloading
 - Management of BB&T
- Single Point of contact for all matters
- Unchallenged flexibility
- Emergency services to ensure maximum reliability



Come visit us STAND 116

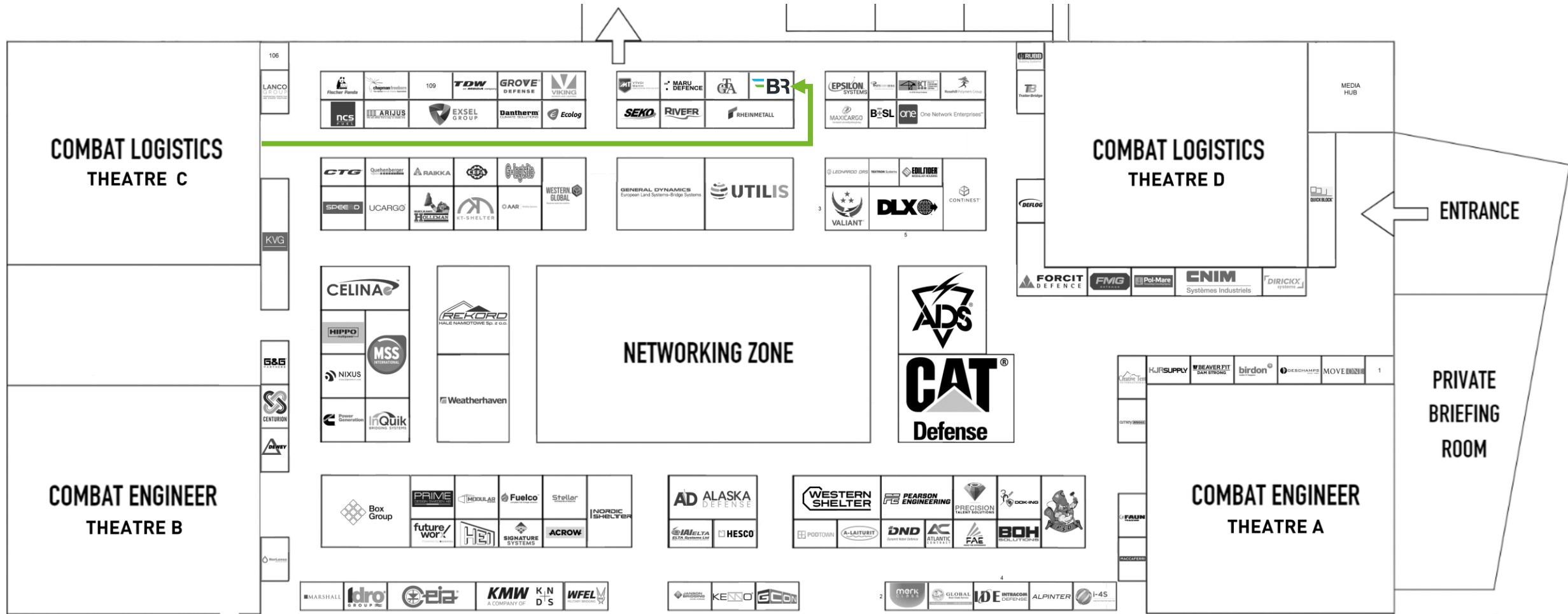



BR

International
Consulting
Services

Developing unique logistics solutions