

# BA

## BOSSALUMINIUM



## M-SPEC & PREMIUM TRAYS







<b>ADVENTURE READY</b>	<b>5</b>
<b>CAPABILITY</b>	<b>6</b>
<b>MATERIALS</b>	<b>7</b>
<b>VEHICLE FITMENT</b>	<b>7</b>
<b>MODULAR SYSTEM</b>	<b>7</b>
<b>M1 TRAY</b>	<b>8</b>
<b>M2 TRAY</b>	<b>9</b>
<b>M3 TRAY</b>	<b>10</b>
<b>M4 TRAY</b>	<b>11</b>
<b>VEHICLE FITMENTS</b>	<b>12</b>
<b>M-SPEC FEATURES</b>	<b>14</b>
<b>PREMIUM TRAYS</b>	<b>16</b>
<b>EXTENDED CHASSIS</b>	<b>18</b>
<b>AMERICAN VEHICLES</b>	<b>20</b>
<b>VEHICLE MODIFICATIONS</b>	<b>22</b>



# ADVENTURE READY

Since 2000, Boss Aluminium has been a leader in delivering top-quality 4x4 and trade solutions. We take pride in developing all of our products in-house, from innovative design to final manufacture. Our diverse range of modular options are tailored to meet your specific needs, ensuring the perfect solution for your ute, no matter the conditions.

# CAPABILITY

For over two decades, Boss Aluminium has been dedicated to excellence in manufacturing, proudly offering 100% Australian-made products. Our commitment to innovation and quality has established us as a prominent leader in the industry. Leveraging state-of-the-art facilities and cutting-edge technology, we ensure that every product we deliver meets the highest standards. Our focus on continuous improvement and technological advancement allows us to stay at the forefront of the manufacturing sector, consistently providing top-tier solutions that meet the evolving needs of our clients.



**Computer Aided Design (CAD):** Every product begins in CAD, ensuring precise prototyping and seamless integration with our manufacturing processes.

**3D Scanning:** Our Artec Leo scanner measures complex geometries to 0.2mm, facilitating accurate design and reverse engineering.

**Laser Cutting:** With our LVD 12kW Phoenix Fibre Laser cutter with automation giving lights out capability, we handle precision cutting of sheet metal up to 4x2 meters and 30mm thick.



**Brake Press Bending:** Our LVD Easy Form Brake Press Bender and the Bystronic Mobile Bending Robot handle various materials and sizes, optimizing efficiency and precision.

**Panel Bending:** The Salvagnini P4L Panel Bender provides high efficiency and accuracy for large-scale sheet metal bending, integrating seamlessly with CAD.



**Welding & Fabrication:** We offer expert MIG and TIG welding and fabrication for both standard and complex projects, ensuring top quality.

**Powder Coating:** Our multi-stage dip process and chrome-free powder coating ensure optimal adhesion and environmental safety, delivering high quality finishes.

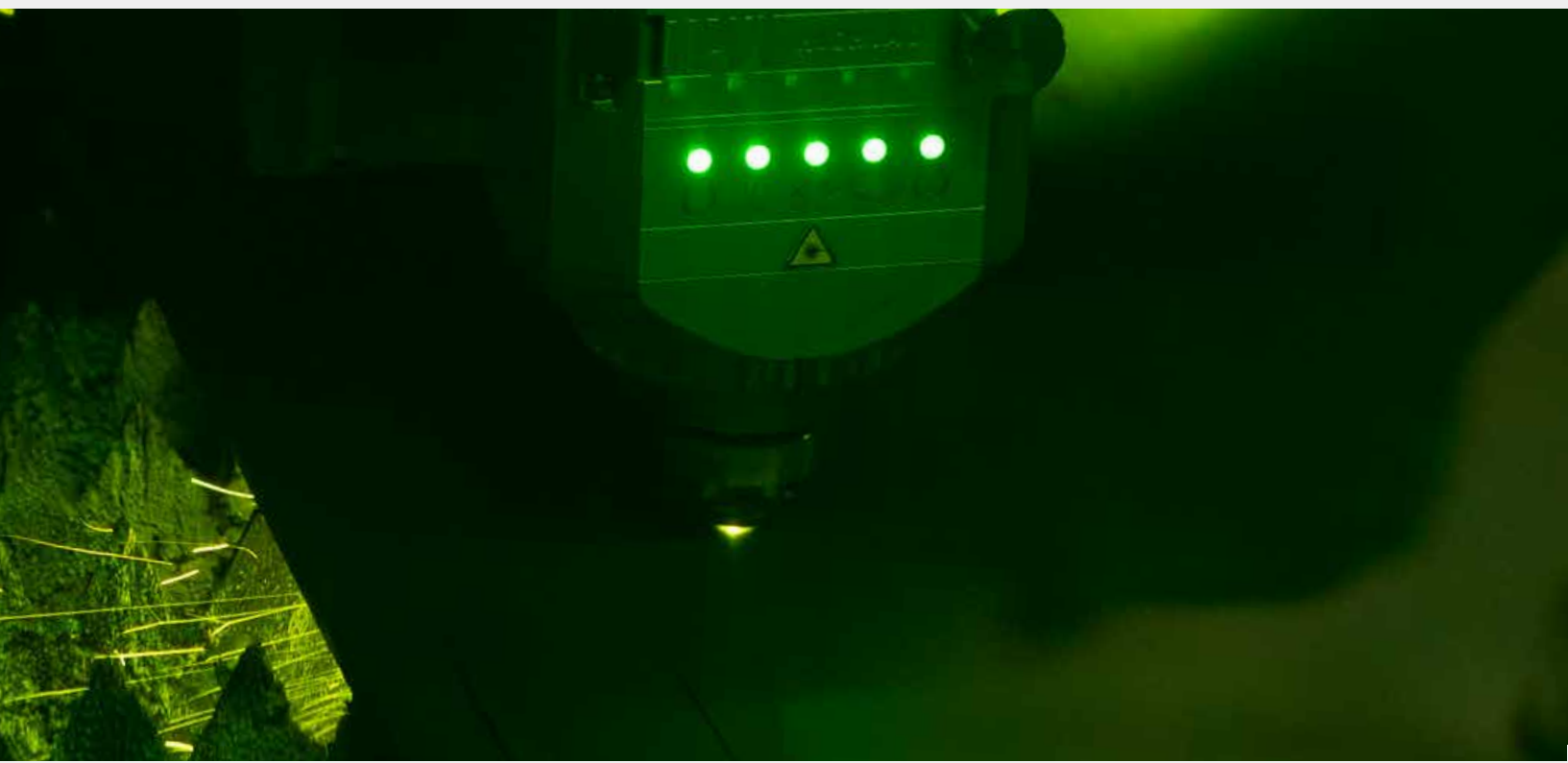

## MATERIALS

At Boss Aluminium, we use a carefully chosen mix of aluminum alloys, with 5052 as the primary material, to ensure durability and performance in our trays and canopies. This approach allows us to match the right properties to specific applications, ensuring our products withstand tough conditions and maintain their integrity over time.

## VEHICLE FITMENT

Boss Aluminium Trays are designed to fit the majority of utes available in Australia.

**M-SPEC:** Our M-Spec range is designed to fit with most mid sized utes like Ford Ranger, Toyota Hilux and Isuzu DMax, as well as the 79 Series Land Cruiser.

**Premium Tray:** Our flagship Premium Tray is available for most larger size utes including 79 Series, Chopped 200 & 300 Landcruisers, Dodge RAM, Chevrolet Silverado, Ford F-Trucks as well as the recent addition of the Ford Ranger to the lineup.

## MODULAR SYSTEM

Our products are built around modularity, allowing for easy customisation and reconfiguration. Choose from a wide range of components and options and work with our team to find the best configuration for you. This design flexibility supports a wide range of applications, from the commercial environment to exploring the furthest corners of Australia.

### TRAYS AVAILABLE IN

#### Full Tray Variants



#### Flatbed Variants



# M1 TRAY

## M-SPEC PACKAGE



## M1 PACKAGE INCLUSIONS

### Features

- M-Spec Flatbed or Full Tray
- Next Gen Tray Deck Incorporating M12 Nutsert Grid System and Tie-Down Rail
- M-Spec Sheet Metal Headboard with Mesh
- Double Skinned Tray Sides
- Heavy-Duty (HD) One-Piece Mudguards
- Classic Tail Infill with Premium Tail Lights

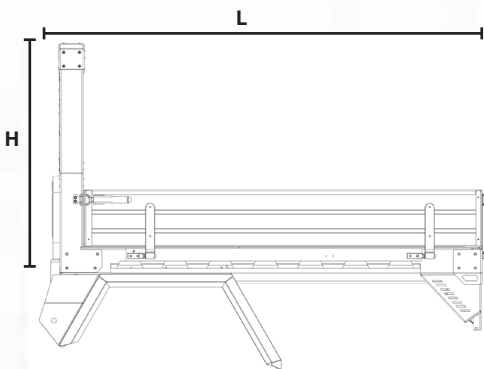

SIDE VIEW

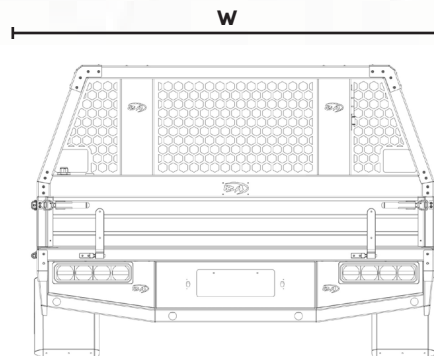

REAR VIEW

DIMENSIONS	H(MM)	L(MM)	W(MM)
Dual Cab Standard Ute	885	1800	1850
LC79 Dual Cab	925	1800	1850



# M2 TRAY

## M-SPEC PACKAGE



### M2 PACKAGE INCLUSIONS

#### Features

- M-Spec Flatbed or Full Tray
- Next Gen Tray Deck Incorporating M12 Nutsert Grid System and Tie-Down Rail
- M-Spec Sheet Metal Headboard with Mesh
- Double Skinned Tray Sides
- Heavy-Duty One-Piece Mudguards
- Classic Tail Infill with Premium Tail Lights
- M-Spec Rear Under Body Boxes (front under body boxes available for single and extra cab)

 <b>FROM 220KG</b> SINGLE CAB	 <b>FROM 198KG</b> EXTRA CAB	 <b>FROM 183KG</b> DUAL CAB
-------------------------------------	------------------------------------	-----------------------------------

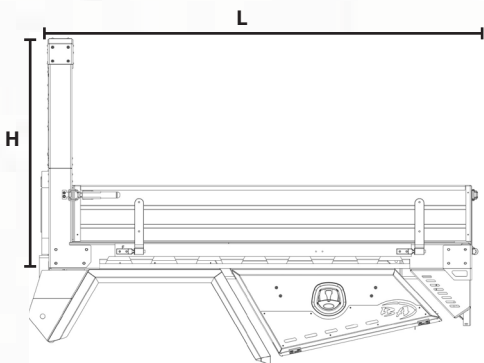

SIDE VIEW

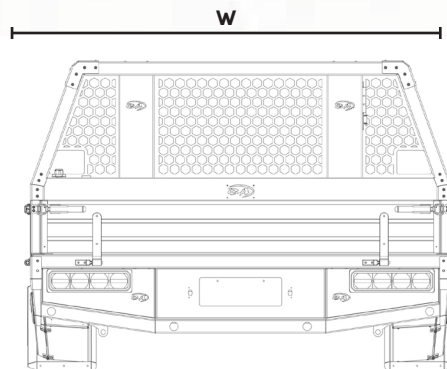

REAR VIEW

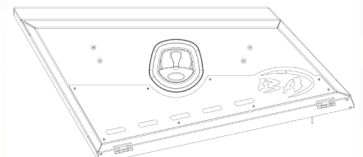

M-Spec Under Body Boxes

DIMENSIONS	H(MM)	L(MM)	W(MM)
Dual Cab Standard Ute	885	1800	1850
LC79 Dual Cab	925	1800	1850

# M3 TRAY

## M-SPEC PACKAGE



## M3 PACKAGE INCLUSIONS

### Features

- M-Spec Flatbed or Full Tray
- Next Gen Tray Deck Incorporating M12 Nutsert Grid System and Tie-Down Rail
- M-Spec Sheet Metal Headboard with Mesh
- Double Skinned Tray Sides
- Heavy-Duty One-Piece Mudguards
- Classic Tail Infill with Premium Tail Lights
- M-Spec Rear Under Body Boxes (front under body boxes available for single and extra cab)
- Under Tray Drawer 1600MM (Dual-cab length)

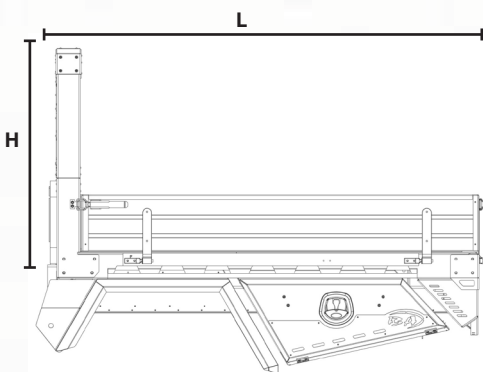

SIDE VIEW

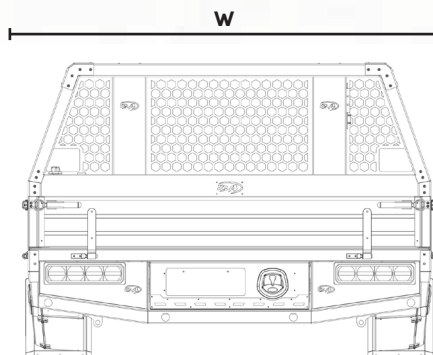

REAR VIEW

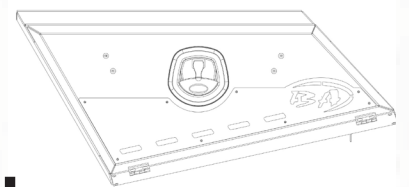

M-Spec Under Body Boxes

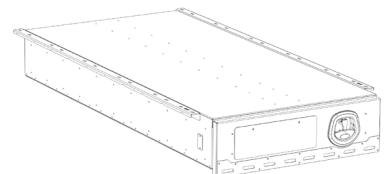

1600mm Undertray Drawer

DIMENSIONS	H(MM)	L(MM)	W(MM)
Dual Cab Standard Ute	885	1800	1850
LC79 Dual Cab	925	1800	1850

# M4 TRAY

## M-SPEC PACKAGE



## M4 PACKAGE INCLUSIONS

### Features

- M-Spec Flatbed or Full Tray
- Next Gen Tray Deck Incorporating M12 Nutsert Grid System and Tie-Down Rail
- M-Spec Sheet Metal Headboard with Mesh
- Double Skinned Tray Sides
- Heavy-Duty One-Piece Mudguards
- Classic Tail Infill with Premium Tail Lights
- M-Spec Rear Underbody Boxes (front under body boxes available for single and extra cab)
- Under Tray Drawer 1000MM
- Under Tray Food-Grade Polyurethane 70L Water Tank

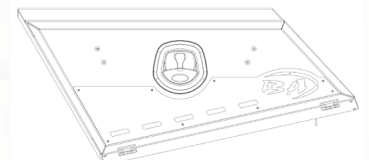
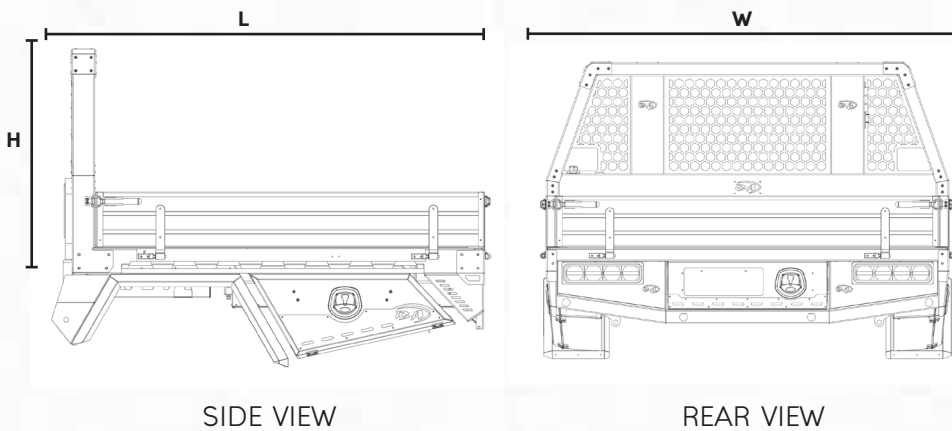

M-Spec Under Body Boxes

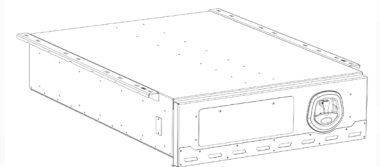

1600mm Undertray Drawer

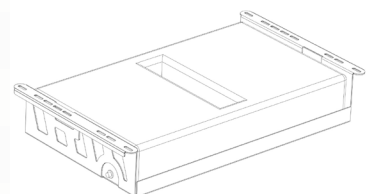

70L Polyurethane Water Tank

DIMENSIONS	H(MM)	L(MM)	W(MM)
Dual Cab Standard Ute	885	1800	1850
LC79 Dual Cab	925	1800	1850

# VEHICLE FITMENTS

## M-SPEC FULL TRAY PACKAGES

FEATURES	M1	M2	M3	M4
M-Spec Full Tray	✓	✓	✓	✓
Heavy Duty One Piece Mudguards	✓	✓	✓	✓
Classic Tail Infill	✓	✓	✓	✓
Powder Coating	✓	✓	✓	✓
M-Spec Rear Under Body Boxes x 2	○	✓	✓	✓
M-Spec Sheet Metal Headboard	✓	✓	✓	✓
Full Tray Sides	✓	✓	✓	✓
Rear Under Tray Drawer 1600mm	○	○	✓	✗
Rear Under Tray Drawer Shortened	○	○	○	✓
Under Tray 70L Water Tank	○	○	✗	✓
40L Headboard Water Tank	○	○	○	○
12v Water Pump	○	○	✗	○
Rear Hoop - Removable	○	○	○	○
Headboard Spare Wheel Mount/s	○	○	○	○
Front Under Body Boxes	○	○	○	○
Colour Code 2-Pac UTD & UBB Doors	○	○	○	○
UBB & UTD Central Locking	○	○	○	○
Additional LED Reverse Lights	○	○	○	○
Blacked-out Hardware	○	○	○	○
Carpet for Underbody Box or Under Tray Drawer	○	○	○	○

✗ NOT AVAILABLE

○ OPTIONAL EXTRA

✓ INCLUDED



Underbody Boxes



40L Headboard Water Tank



Rear Under Tray Drawer

## M-SPEC FLATBED TRAY PACKAGES

FEATURES	M1	M2	M3	M4	
M-Spec Flatbed Tray	✓	✓	✓	✓	
Heavy Duty One Piece Mudguards	✓	✓	✓	✓	
Classic Tail Infill	✓	✓	✓	✓	
Powder Coating	✓	✓	✓	✓	
M-Spec Rear Under Body Boxes x 2	○	✓	✓	✓	⊗ NOT AVAILABLE
M-Spec Sheet Metal Headboard	⊗	⊗	⊗	⊗	
Shortened Double Skinned Tray Sides to Suit Canopy & Toolboxes	○	○	○	○	○ OPTIONAL EXTRA
Rear Under Tray Drawer 1600mm	○	○	✓	⊗	
Rear Under Tray Drawer Shortened	○	○	○	✓	
Under Tray 70L Water Tank	○	○	⊗	✓	
12v Water Pump	○	○	⊗	○	
Rear Hoop - Removable	○	○	○	○	✓ INCLUDED
Front Under Body Boxes	○	○	○	○	
Colour Code 2-Pac UTD & UBB Doors	○	○	○	○	
UBB & UTD Central Locking	○	○	○	○	
Additional LED Reverse Lights	○	○	○	○	
Blacked-out Hardware	○	○	○	○	

## DIMENSIONS

Dual Cab	1800L x 1850W
Extra Cab	2100L x 1850W
Single Cab	2500L x 1850W
Dual Cab - LC 79 Series	1800L x 1850W
Dual Cab - LC 79 Series 300mm Extension	2100L x 1850W
Single Cab - LC 79 Series	2500L x 1850W

## WEIGHT

PACKAGE	DUAL CAB	EXTRA CAB	SINGLE CAB
M1	158kg	173kg	195kg
M2	183kg	198kg	220kg
M3	235kg	250kg	272kg
M4	227kg	242kg	264kg

# M-SPEC FEATURES



## Modular Tray System

Our modular, M-Spec design allows for interchangeable configurations and easy adjustments to meet various needs.



## Integrated Tie Down Rail

Built-in rail system for secure cargo attachment and enhanced load stability.



### LED Tail Lights

High-performance tail lights that offer superior visibility and durability for enhanced rear lighting.



### Reverse Sensors and OEM Sonar

Integrated factory reverse, parking sensors, sonar brackets and wiring to maintain all OEM technology with the vehicle.



### Checker Plate Tray Deck with Nutserts

Durable checker plate surface equipped with nutserts for versatile and secure tie-down options.



### Integrated Headboard Electrical Plugs

Provisions for electrical plugs including Anderson Plugs (Solar, Canopy and Auxiliary) and Deutch plug.

# PREMIUM TRAYS

## OUR FLAGSHIP

The Boss Aluminium Premium Tray represents the pinnacle of Australian-made trays. Building on the expertise gained from our M-Spec series, it offers a refined, all-in-one package. This tray is the ideal choice for those seeking a durable solution with all the bells and whistles.

### Standard Dimensions

LC79 Dual Cab - 1800L x 1850w  
LC79 Single Cab - 2400L x 1850w





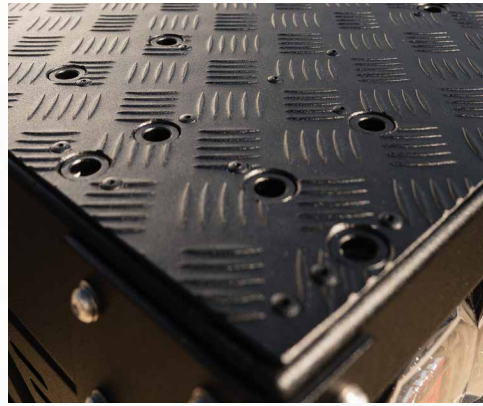

### Checker Plate Tray Deck with Nutserts

Durable checker plate surface equipped with nutserts for versatile and secure tie-down options.



### Under-Body Boxes with Internal Shelving

Spacious under-body storage boxes with built-in shelving & carpet for organized and secure storage of tools and equipment. Size dependent options for compressor mount and shelving.



### Under Tray Drawer

A large, easily accessible under-tray drawer offering additional storage space for longer items.

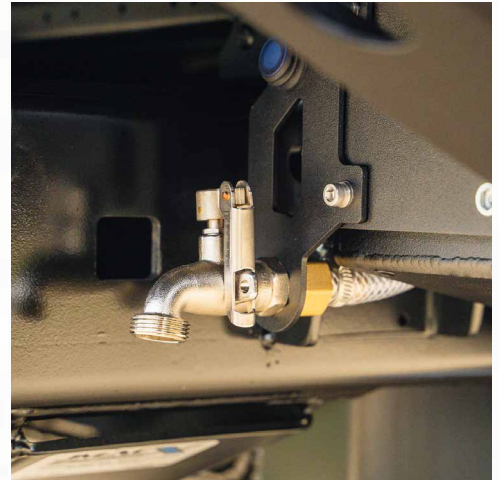

### Under Tray Food-Grade Polyurethane 70L Water Tank

A durable, food-grade 70L water tank made from polyurethane, seamlessly integrated under the tray for convenient water storage.

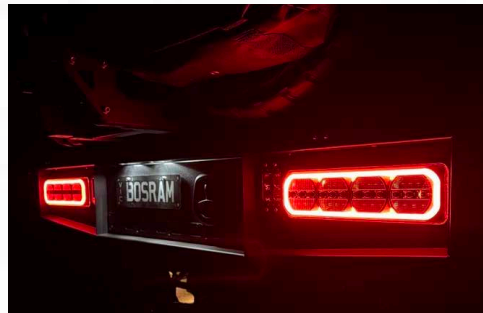

### Premium Tail Lights

Free upgrade option to premium lights providing enhanced brightness and a sleek appearance.



### Multi-Function Headboard

Featuring integrated side & rear worklights, integrated fuel & AdBlue fillers with optional 85L stainless or 40L polyurethane water tanks.



### Double Skinned Checker Tray Sides

Reinforced checker plate tray sides with a double skin for increased strength

# EXTENDED CHASSIS

## LC79 W/300MM EXTENSION / 300 SERIES / 200 SERIES

### Dimensions

- LC79 Dual Cab with 300mm Extension - 2000L x 1850W
- LC79 Single Cab with 300mm Extension - 2800L x 1850W
- LC200/300, Extension Dependent - 1700L, 2000L or 2200L x 2000w



JMACX AEV LC300 W/600MM CHASSIS EXTENSION. TRAY: 1700L X 2000W





# AMERICAN VEHICLES

## Dimensions

RAM 1500, F150, Silverado 1500 1950L x 2000W

RAM 2500, RAM 3500 2200L x 2000W

F250, F350, Silverado 2500, GMC 2500 2350L x 2000W





# VEHICLE MODIFICATIONS

## JMACX AUTHORISED INSTALLER

Boss Aluminium offers a one-stop shop for 79 Series builds. Fitting a wide range of accessories for your vehicle, along with our signature trays and canopies, you can get all the work you need done in one go. From chassis extensions to coil conversions, speak with our team to discuss the best available options for your vehicle.



GVM Upgrades



Chassis Extensions



6x6



12V



**BOSS ALUMINIUM PTY LTD**

Ph. (03) 9729 3092

[sales@bossaluminium.com.au](mailto:sales@bossaluminium.com.au)

[www.bossaluminium.com.au](http://www.bossaluminium.com.au)

