

A photograph of an industrial robotic welding process. Two red robotic arms are positioned over a metal workpiece, with bright sparks and a glowing blue light emanating from the point of contact. The background shows a factory setting with various equipment and structures.

Anybus[®]
BY HMS NETWORKS

Diagnostics

Ensuring network uptime
and security

Hms

Reduce or eliminate downtime with Anybus Diagnostics

Downtime is the nemesis of every single industry, with hugely detrimental effects on production, output, revenues, and sustainability.

But fear not! Anybus Diagnostics offers a comprehensive range of products and services, empowering industrial companies to proactively implement preventive techniques. Experience significant reductions or even complete elimination of downtime.

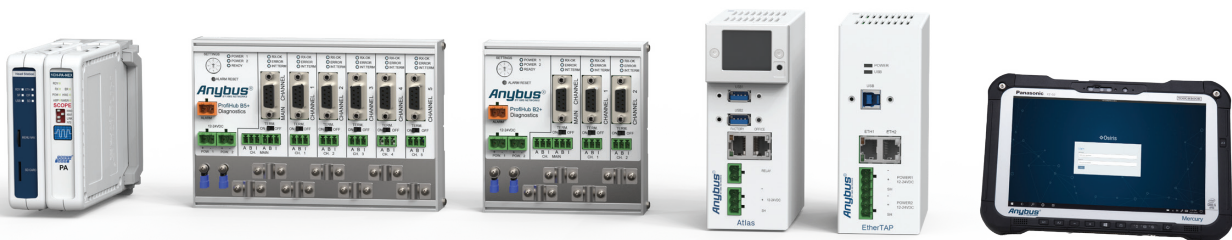

Anybus Diagnostics' range of products and services!

- Permanent Monitoring of Industrial Ethernet or fieldbus networks: Be forewarned!
- Network Segmentation: Build a robust network
- Network Insights: Utilize AI for efficient troubleshooting!
- Diagnostics Academy: Train your staff and enhance your network's health!

Permanent Monitoring of Industrial Ethernet Networks

In today's interconnected industry, ensuring the security, reliability, and efficiency of industrial networks is paramount. With the utilization of permanent network monitoring, encompassing both active and passive tools, you can proactively detect and mitigate security vulnerabilities, significantly reduce downtime, and optimize overall performance. This combined approach allows you to implement a comprehensive and highly effective permanent monitoring system, precisely tailored to meet the unique requirements of your industrial network.

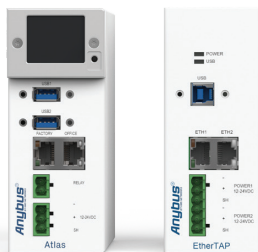

The Anybus Atlas2 Plus and EtherTAP2 offer the perfect combination to perform active and passive network monitoring.



Why do I need permanent monitoring tools?

- Cost-effective solutions designed specifically for monitoring Industrial Ethernet networks.
- Accelerate troubleshooting by analyzing and visualizing real-time diagnostic data.
- Minimize or prevent downtime through fault-finding capabilities.
- Simplify maintenance by consolidating results into a single, comprehensive overview.

Products

Anybus Atlas2 Plus

The Anybus Atlas2 Plus is a powerful permanent monitoring tool that provides continuous diagnostics information for your industrial Ethernet network. With 24/7 monitoring, field technicians can ensure network uptime, maintain a healthy network, and proactively troubleshoot issues to minimize or even prevent costly downtime.

Whether you're using PROFINET, EtherNet/IP, or EtherCAT, the Atlas2 Plus offers a connected and predictive approach to machine health monitoring and maintenance.

This unique hardware reads industrial ethernet traffic and is single-mounted on the DIN rail in a cabinet connected to the office and factory port.



Anybus EtherTAP2

The EtherTAP2 is an advanced monitoring interface that enables in-depth analysis of PROFINET and EtherNet/IP traffic. It provides round-the-clock access to passive diagnostics, allowing for early detection of communication errors.

With its upgraded housing, based on the Atlas2 Plus, the EtherTAP2 transforms into an effective permanent monitoring solution. Designed for easy installation on a DIN rail, it can be conveniently placed side-by-side with your Atlas2 Plus, offering a seamless monitoring experience.



Permanent Monitoring of Fieldbus Networks

Permanent monitoring of fieldbus networks is vital for maintaining the optimal performance and reliability of industrial automation systems. By monitoring the network's health and performance in real time, you can swiftly detect potential issues and abnormalities, allowing you to take proactive measures and prevent them from developing into major problems.

The use of permanent monitoring tools provides invaluable insights into network behavior at both the message and electrical signal levels, ensuring round-the-clock information on the overall network health. With these tools at your disposal, you can stay well-informed and promptly address any issues, thereby guaranteeing the optimal performance and reliability of your network.



Anybus ComBricks offer more than just network monitoring. Their modular system also enables you to create segmentations that enhance the strength of your network backbone.



Why do I need permanent monitoring tools?

- Cost-effective solutions designed specifically for monitoring fieldbus networks.
- Accelerate troubleshooting by analyzing and visualizing real-time diagnostic data.
- Minimize or prevent downtime through fault-finding capabilities.
- Simplify maintenance by consolidating results into a single, comprehensive overview.

Products

Anybus ComBricks

The Anybus ComBricks is a modular platform that enables you to actively monitor PROFIBUS DP and PROFIBUS PA networks 24/7. It provides real-time alerts for any faults that arise or are likely to arise. With its modular design, you can easily customize and expand the platform to meet your specific monitoring needs. Additionally, it offers the flexibility to convert PROFIBUS DP to PROFIBUS PA or to Fiber Optics. Convenient remote access can be established through its integrated webservice.



Network Segmentation

Many companies choose to retain their legacy fieldbus networks and often expand them by adding new devices in a daisy chain topology. However, this approach poses a significant risk, as a problem in a single device can cause the entire network to fail, resulting in unplanned downtime.

To solve this issue, Anybus Diagnostics provides network segmentation products that divide the network into separate segments, isolating any issues and preventing them from impacting the entire system. By utilizing multiple tap points, network segmentation not only minimizes the risk of downtime but also simplifies troubleshooting by allowing engineers to swiftly identify and resolve issues without disrupting the rest of the network.

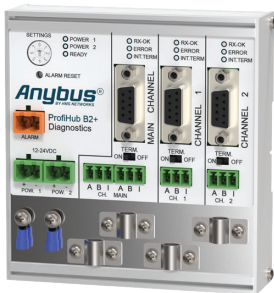

The Anybus ProfiHubs can be detected by the ComBricks, which allows you to view every channel individually via the integrated web server

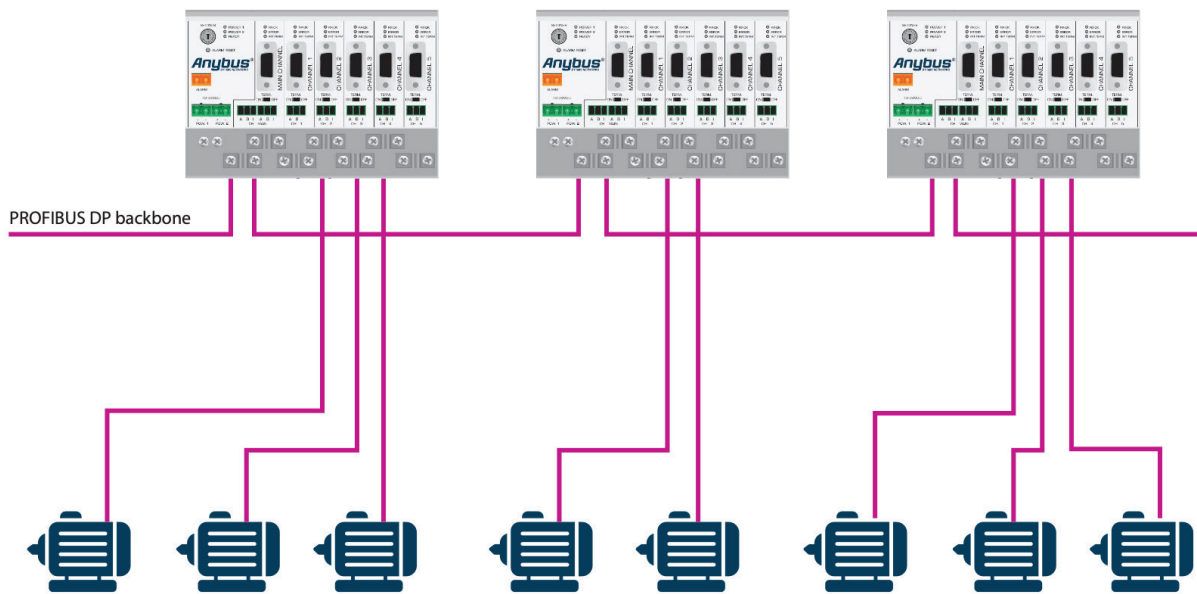

Products

Anybus ProfiHub

Creating a robust and reliable network infrastructure is vital for maintaining a healthy network. With network segmentation, you can implement various topology types to enhance reliability and significantly extend the lifespan of your plant.

The Anybus ProfiHub is a multi-channel repeater for PROFIBUS DP networks. Each channel is galvanically isolated, ensuring that any electrical issues are contained within the specific channel and do not affect other channels. Additionally, each channel is equipped with a DB9 connector, allowing you to connect a mobile diagnostics tool for in-depth troubleshooting.

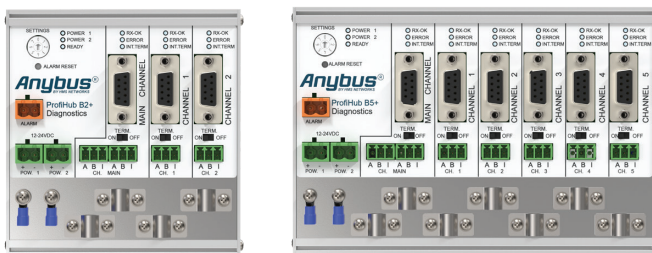

In PROFIBUS networks, the ProfiHubs offer a reliable and robust network backbone where each channel has its own individual switchable termination. The ProfiHubs also allow you to implement cable redundancy in your PROFIBUS networks, enhancing the reliability and fault tolerance of your network.

Network Insights

Troubleshooting errors in industrial networks can be challenging, as it often requires extensive experience and knowledge of various industrial protocols. As networks become more complex, identifying and resolving issues becomes even more difficult.

Anybus Diagnostics solves this problem by offering SNAP, an AI-powered software that can quickly and accurately analyze the network to identify the root cause of any issues. SNAP reduces the need for field engineers to have years of experience and can streamline the troubleshooting process, ultimately saving companies time and money.

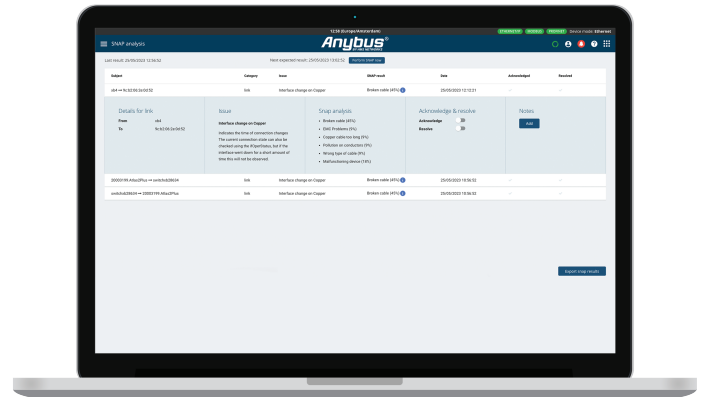

Benefits of Network Insights

- 
- Automatic analysis and visualization of real-time diagnostic data, eliminating guesswork when troubleshooting device issues.
 - Quickly and accurately identifies faults, enabling you to implement proactive measures and prevent critical network crashes.
 - Guided assistance helps you swiftly pinpoint the most likely cause, source, and optimal path for repair.

Diagnostics Academy

Creating a healthy industrial network requires more than just reliable hardware and software; it also demands skilled professionals. That's why Anybus Diagnostics provides comprehensive e-learning and certified training courses that equip engineers with essential skills and knowledge to increase uptime in their factories.

These tailored training courses offer hands-on experience, enabling engineers to effectively design, install, maintain, and troubleshoot industrial networks. By utilizing Anybus Diagnostics' training courses, companies can close any knowledge gaps in their staff, leading to improved performance and increased uptime of their industrial networks.

Certified Training Courses



While PROFIBUS and PROFINET are widely used and user-friendly automation technologies, comprehensive training is essential for individuals utilizing these advanced technologies. Training equips participants with the necessary skills and confidence to effectively implement and utilize PROFIBUS and PROFINET. In the long run, investing in the appropriate training is key to ensuring smooth operations without unforeseen downtime.



Benefits of training courses

- Executing projects much more efficiently thanks to personnel equipped with practical knowledge about network components, cabling, interference, design, configuration, and common errors.
- Proficient handling of diagnostic tools and effective utilization of the information visualized by these tools, resulting in much more efficient testing, commissioning, and troubleshooting.
- Cost savings through reduced time spent on solving technical issues, thanks to technicians who are comfortable working with advanced technology. optimal path for repair.

eLearning



Demonstrate your technical knowledge before installing, maintaining, or troubleshooting industrial networks such as PROFIBUS, PROFINET, EtherNet/IP, or EtherCAT.

Untrained staff cause at least 75% of industrial network issues, leading to unnecessary downtime. Don't be one of them!

With Anybus' eLearning courses, you can learn a specific area of network engineering in as little as 30 minutes. Whether you're new to the industry or have years of experience, our eLearning platform allows you to update, expand, and showcase your knowledge to the world. The course material provides excellent preparation for achieving an official PI certification.



Benefits of eLearning:

- Access to experienced experts in the field.
- Bite-sized online learning modules with clear instructions.
- Internationally recognized certificates for certified courses.
- Technical theory combined with practical exercises.
- High-quality training customized for any industry.
- Proof to employers and customers that you have the right skills and knowledge.





Work with HMS Networks.
The number one choice for
industrial communication
and IIoT.

Anybus[®]
BY HMS NETWORKS

Ewon[®]
BY HMS NETWORKS

Intesis[®]
BY HMS NETWORKS

Ixxat[®]
BY HMS NETWORKS

HMS Networks - Contact

HMS is represented all over the world. Find your nearest contact here:

<https://www.anybus.com/contact>

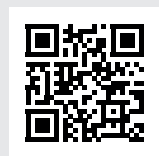

Anybus[®], Ewon[®], Ixxat[®] & Intesis[®] are registered trademark of HMS Industrial Networks AB, Sweden, USA, Germany and other countries.
All other product or service names mentioned in this document are trademarks of their respective companies.
© HMS Industrial Networks - All rights reserved - HMS reserves the right to make modifications without prior notice.



www.anybus.com