

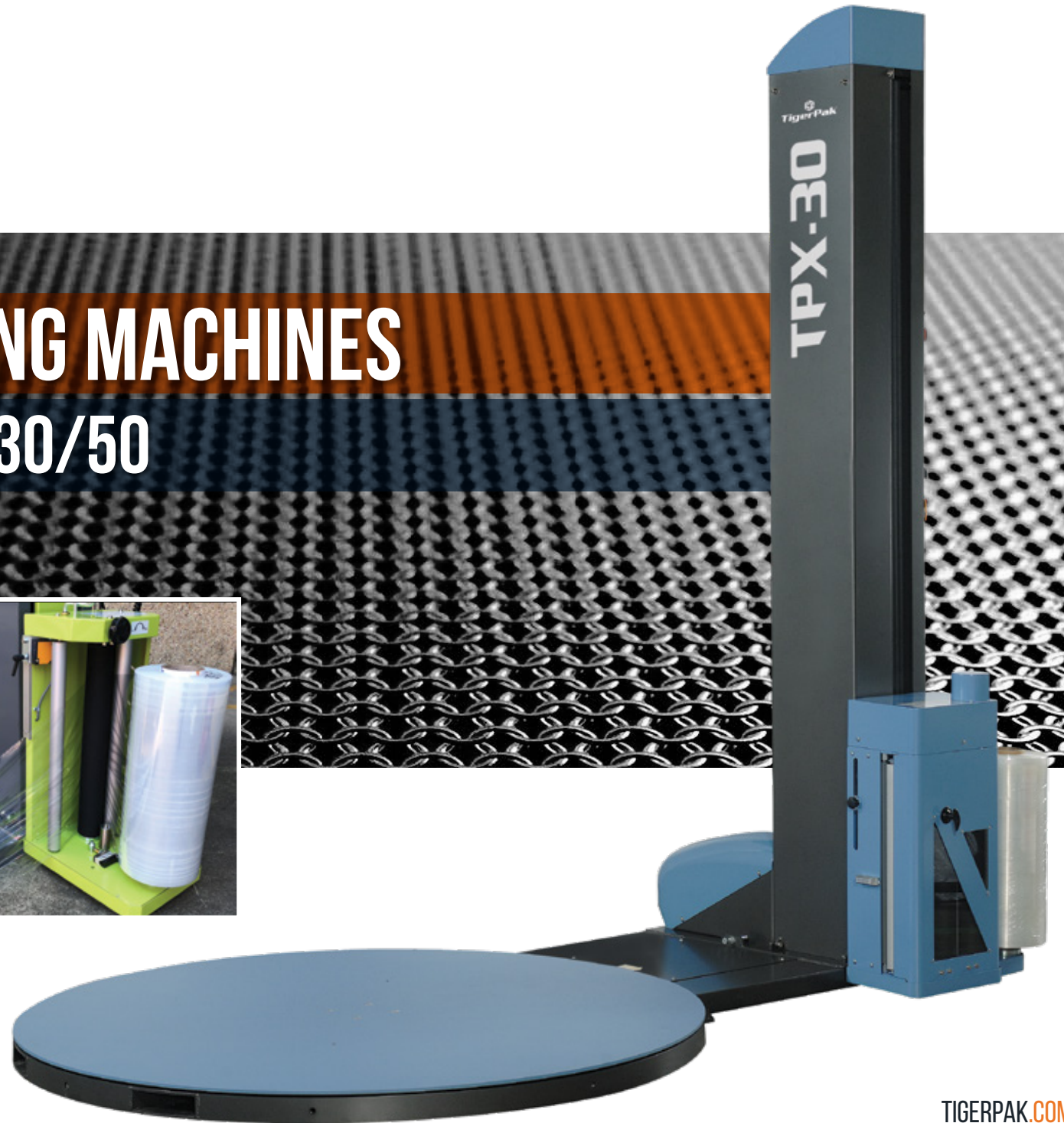

PALLET WRAPPING MACHINES

TPX SERIES 10/20/30/50



TPX-10 SEMI-AUTO STRETCHFILM MACHINE

- Stock Code 2808.
- Reliable, trouble free entry level machine.
- Auto height sensor by photo cell eye.
- Simple easy to use semi-automatic machine.
- Soft start stop with turntable home position.
- Adjustable spring brake.
- One touch automatic program:
 - a) 2 bottom wraps and 1 top wrap
 - b) 3 bottom wraps and 2 top wraps
- Safety switch to prevent foot pinch.
- Height detection by photo sensor.

SPECIFICATIONS:

Wrap Height	2.1m
Turntable Speed	10 Rpm
Loading Weight	1200Kg
Turntable Diameter	1500mm
Power Supply	240V., 50/60Hz.
Power Consumption	0.8Kw



OPTIONS:

- > Ramp.
- > Extended Mast
 - 2.5m
- > Turntable Diameter
 - 1.65m - 1,650 kg. loading

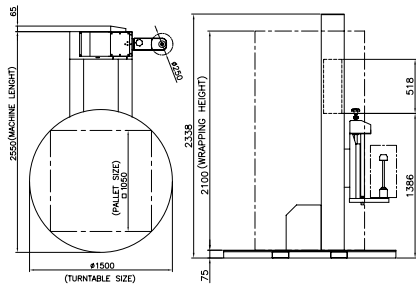

TPX-20 SEMI-AUTO STRETCHFILM MACHINE

- Stock Code 2007.
- Fully adjustable semi-automatic.
- Automatic height sensor by photocell eye.
- Soft start and stop with turntable home position.
- Heavy duty disc brake stretch system.
- Choice of automatic/manual modes.
- Adjustable top and bottom wrap counts
- Adjustable turntable speed/carriage speed.
- 180 degree rotating control box.
- Trouble shooting shown on screen.
- Manual reinforcing wrapping.
- Safety switch to prevent foot pinch.
- Height detection by photo sensor.

SPECIFICATIONS:

Wrap Height	2.1m
Turntable Speed	12 Rpm
Loading Weight	1650Kg
Turntable Diameter	1500mm
Power Supply	240V., 50/60Hz.
Power Consumption	0.8Kw



OPTIONS:

- > Ramp.
- > Extended Mast Options
 - 2.5m
 - 3.0m
- > Turntable Diameter
 - 1.65m -1,650 kg. loading
 - 1.80m - 2,000 kg. loading

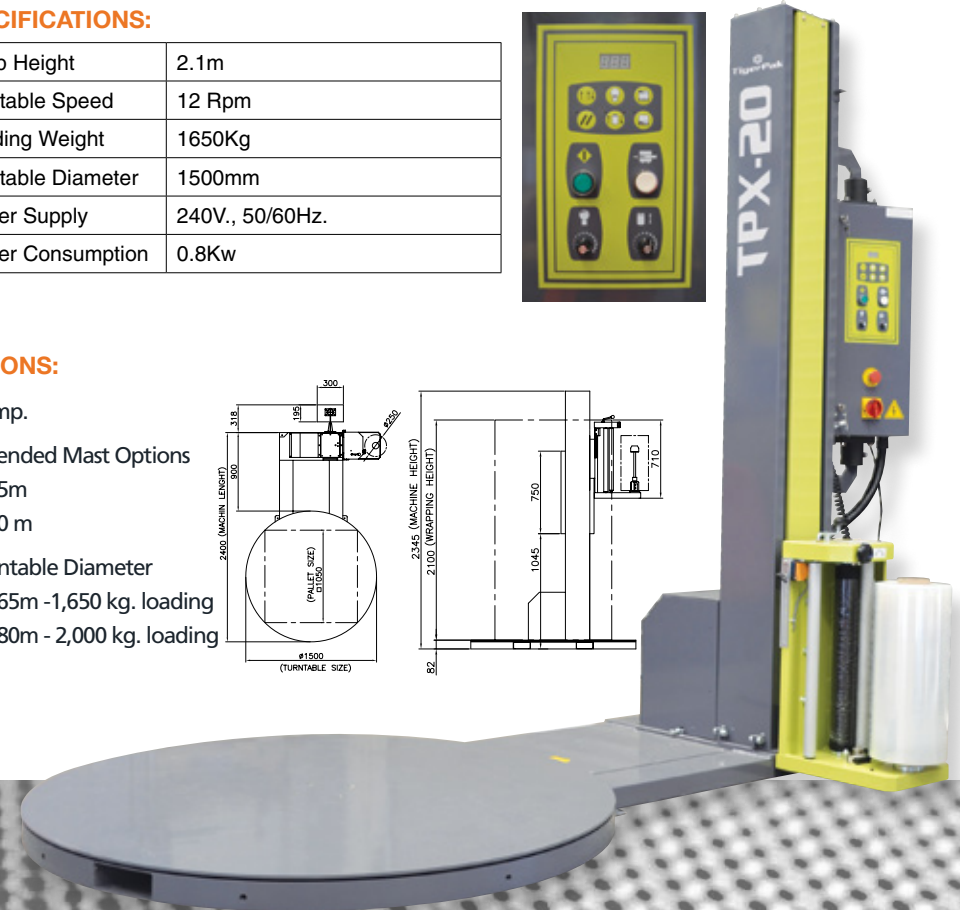
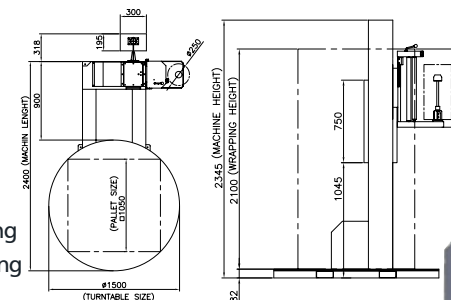

TPX-30 POWER PRE-STRETCHFILM MACHINE

- Stock Code 2805.
- 230% or 300% power pre-stretch with quick gear change.
- Turntable home position.
- Slow start and stop.
- Choices of automatic/manual modes.
- Adjustable top and bottom wrap counts.
- Adjustable wrapping tension (3 stages).
- Adjustable turntable/carriage speed.
- Adjustable reinforcing wrapping.
- Password protected control panel.
- Top sheet wrapping.
- Memory mode.
- Trouble shooting shown on screen.
- Advance soft wrapping.
- Automatic film pin puncture.
- One way idle roll.

SPECIFICATIONS:

Wrap Height	2.2m
Turntable Speed	12 Rpm
Loading Weight	2000Kg
Turntable Diameter	1650mm
Power Supply	240V., 50/60Hz.
Power Consumption	1.2Kw

OPTIONS:

- > Weighing scale kit (turntable 1.65m/2000kg)
- > Ramp.
- > Extended Mast Options
 - 2.6m
 - 3.0m
- > Pressure plate for light loading.
- > Turntable Diameter
 - 1.80m - 2,000 kg. loading

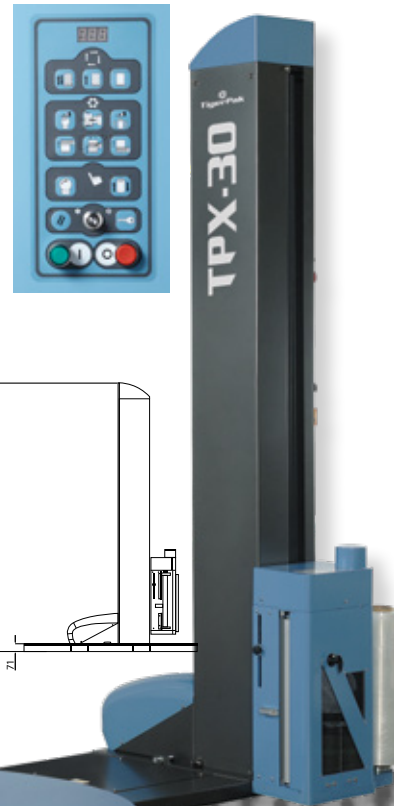
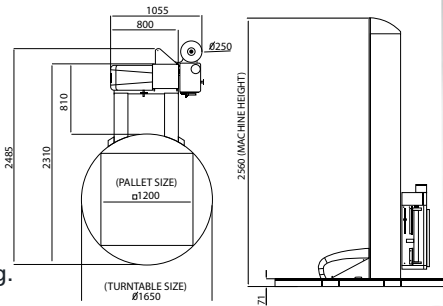

TPX-50 FULLY-AUTO POWER PRE-STRETCH

- Stock Code 2820.
- 300% power pre-stretch (1 meter film pre-stretched to be 4 meters.)
- Fully automatic machine with remote control available, so you can operate without getting off the forklift.
- Turntable home position.
- Slow start and stop.
- Choices of automatic/manual modes.
- 180 degree rotating control box.
- Fully adjustable parameters from electronic control panel.
- Adjustable wrapping tension/ turntable speed/carriage speed.
- Trouble shooting shown on screen.
- Manual reinforcing wrapping.
- Safety switch to prevent foot pinch.

SPECIFICATIONS:

Wrap Height	2m
Turntable Speed	12 Rpm
Loading Weight	2000Kg
Turntable Diameter	1800mm
Power Supply	240V., 50/60Hz.
Power Consumption	1.2Kw
Air Consumption	19L/Min

OPTIONS:

- > Extended Mast Options
 - 2.5m
 - 3.0 m
- > Ramp for 1.8m.
- > Remote control.
- > Pneumatic film roping.

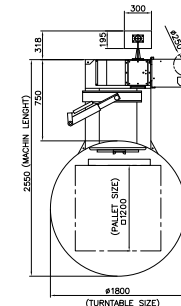

ACCESSORIES

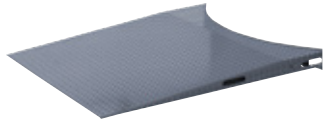

Pallet Wrapper Ramp

Option to add a heavy duty ramp to the pallet wrapping machines.



Photo Sensor for Black Film

Option to add a photo sensor for wrapping matte black products such as tyres or hydraulic hose.

RECOMMENDED STRETCH FILM



PowerWrap
premium grade stretch film

Machine Grade Stretch Film

★ ★ ★
**3 YEAR
EXTENDED
WARRANTY
AVAILABLE**

DOES YOUR PALLET WRAPPER NEED A SERVICE?

- Large range of spare parts in stock.
- Fast, reliable service to all makes and models.
- On site repair and preventative maintenance service.
- Preventative maintenance service program available from only \$249 + GST.



Expert Technicians



Preventative Maintenance



Large Range of Spare Parts in Stock



On Site Repairs

**Contact us for an
Obligation Free Quote Today!**



BOOK A
SERVICE ONLINE

TigerPak

Sydney - Melbourne

P. 1300 525 325

F. 1300 525 326

E. sales@tigerpak.com.au

tigerpak.com.au