

We
make
ideas
flow.

bürkert
FLUID CONTROL SYSTEMS



/ Bürkert Australia has partnered with Australian industry for over 40 years / Our focus is to help our customers by delivering superior service and reliable products when expected - every time.

Your trust in us as unique partners for Fluid Control Systems continues to inspire us to innovate. In Australia, we work with customers of all sizes and across all industries. That's the heart of what makes our jobs so rewarding. And from time to time, we are fortunate to encounter (and even participate in) work that is so compelling and inspiring, we know it is at the launch pad of greatness for Australian businesses.

In these rapidly changing times, we want to be closer to you and listen to your challenges, capturing insights about your likes and dislikes, and what you need to take your operations to new levels of efficiency and productivity. We are committed to finding innovative ways to lower your total cost of ownership and improve your asset utilisation.

At Bürkert we're committed to making your ideas a reality.





Cuong Vo - General Manager / Bürkert Australia





THREE WAYS TO YOUR SOLUTION

At Bürkert we provide a number of solutions for our customers so they can get what they need, when they need it. Fast and efficient 24/7 ordering through our eShop, strong collaboration with our technical sales staff and working personally with our team of Bürkert experts for customised projects.

Standard products Order online			 Time saving
Product Solutions Contact us			 Ideal product
Complete Solutions Develop solutions with us			 Perfect fit



CUSTOMISED SOLUTIONS TO MEET YOUR NEEDS

Each Systemhaus around the globe, including Sydney Australia, has project teams of experienced sales consultants, qualified industry specialists and dedicated engineers work closely with you to develop efficient, reliable and tailor - made results from your initial concept through to system implementation.





Food & Beverage

Solenoid Valves



Process Valves



Control Valves
Electromotive Valves



Sensors, Transmitters
and Controllers



Manufacturing



Pharmaceutical



Water Treatment



Mining



Biotechnology



Pneumatics and Process Interfaces

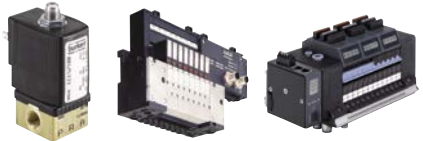

Ex Product



Mass Flow Controllers



Microfluidic Valves and Pumps





EtherNet/IP™

Use IO-Link
Universal · Smart · Easy

Bürkert

LEADING THE WAY IN INTELLIGENT NETWORKING

/ Bürkert leads the way in networked automation / With decades of experience in developing and implementing solutions by providing worldwide connectivity options that cater to our customers' requirements, regardless of plant processes, preferred setup or integration needs.

Driven by the movement of volume production and process automation throughout industries, we aim to simplify and provide peace of mind by offering reliability in both fit-for-purpose products and support.

Bürkert provide a number of gateway and networked options for customers with adaptable and integrative product and technology. As world leaders in supporting core and essential industries, continual innovation is imperative to meet growing demands.

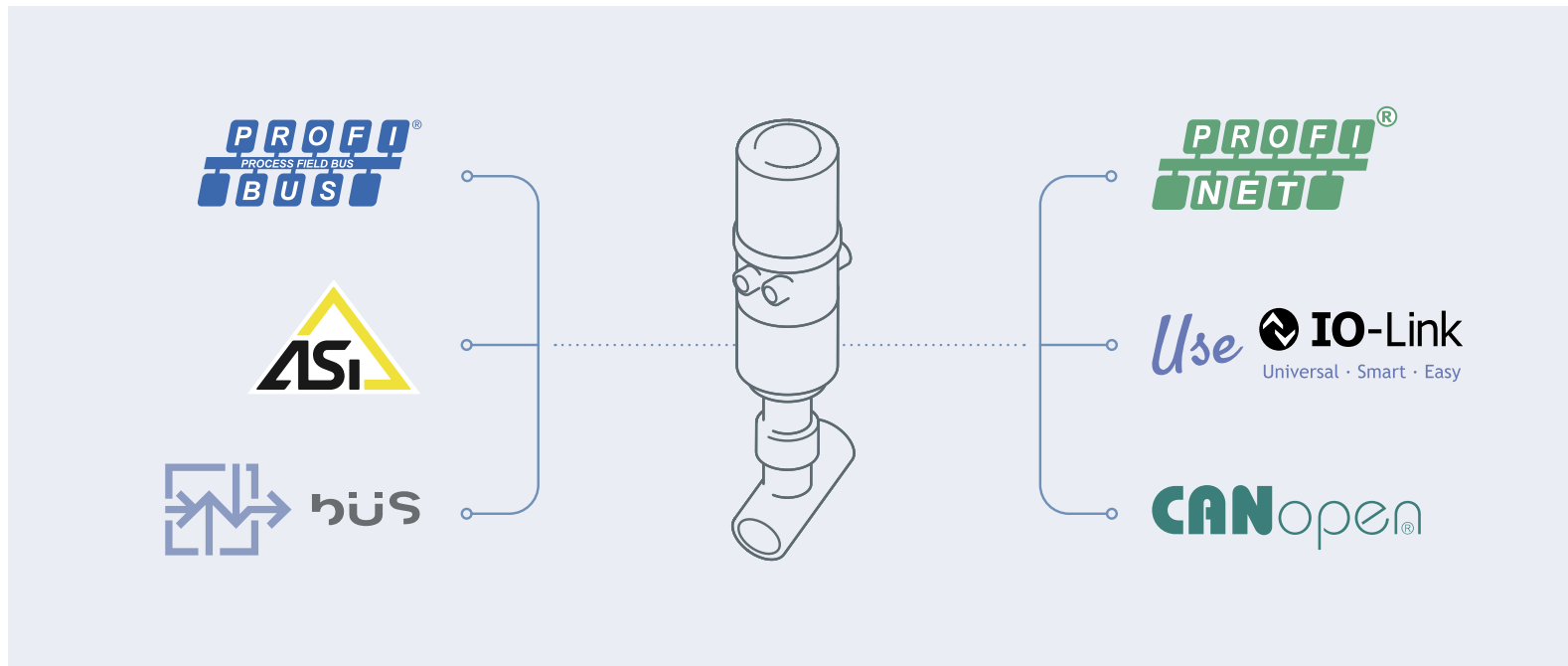

WHY CUSTOMERS CHOOSE BÜRKERT



“During the pandemic in 2020 there were limitations to site access during lockdown, however we had confidence in Bürkert’s solution to continue the accurate water quality monitoring for the test site.”

Mathew French
Area Manager - Projects / Hydroflow



“Our indoor and outdoor pilot plants are critical to our work and we thank DSI-Tec and Bürkert for working so professionally and constructively to provide us with the automated control systems that we require.”

Dr Juliane Wolf
Research Officer and Project Manager / Gas Dosing Control



“The most noticeable positive impact of this solution was the diagnostic information provided from the network connected field devices”

Harry Robinson
Project Engineer for Treasury Wine Estates



“For us, the main benefits of the Burkert control heads are moisture control due to the control tops being internally pressurized – positive pressure to prevent any moisture ingress. Plus their excellent IP rating and lid removal for easy access.”

Michael Mountain
System Improvement Manager / Norco

EVERY MARKET IS DIFFERENT

What influence does closeness have on the flow?

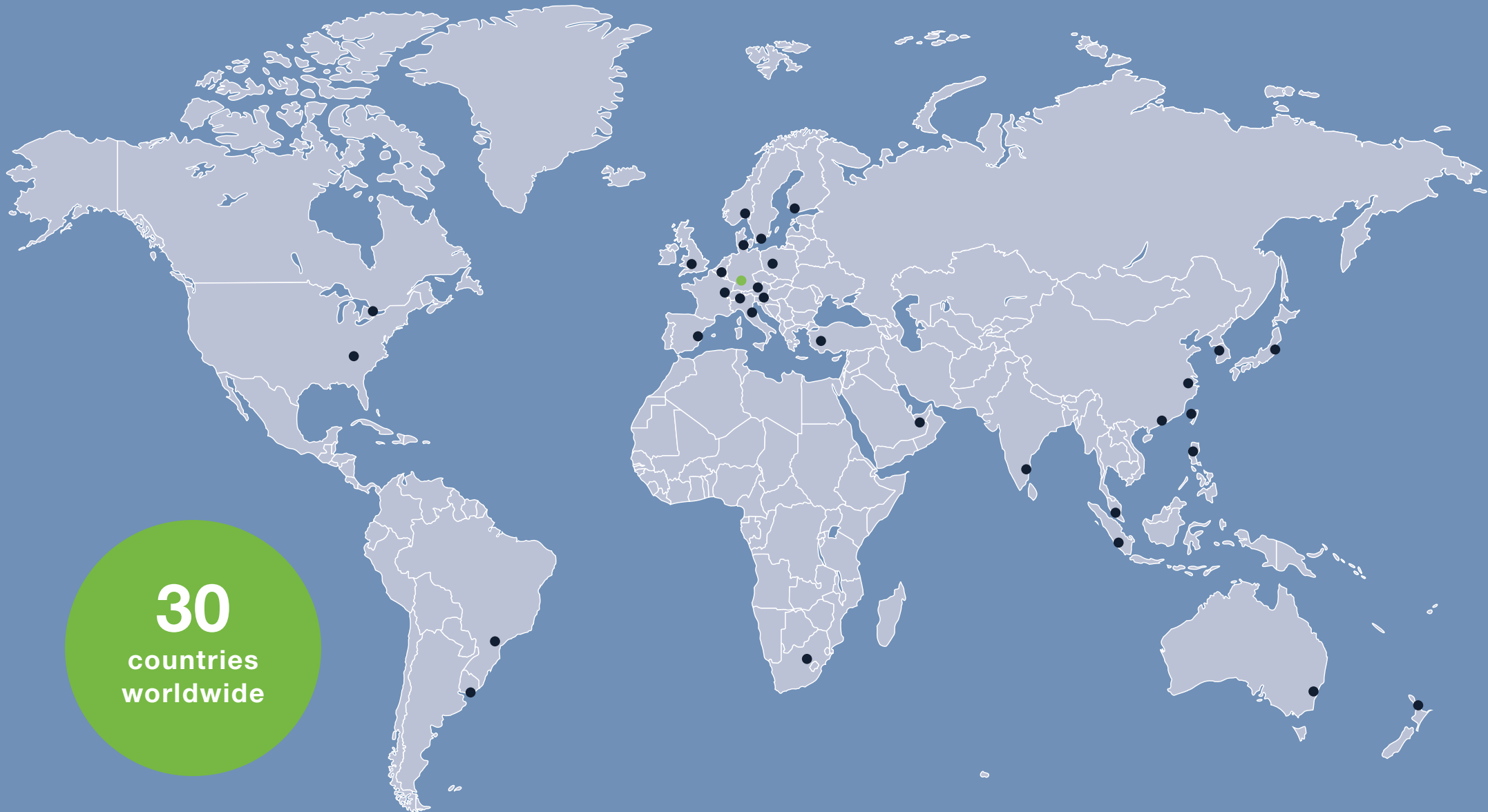

30

countries
worldwide

WE GIVE EVERYTHING

What influence does independence have on the flow?

Independence is worth a lot to us:

- as an internationally positioned family enterprise
- we reinvest our profit in full,
- to have all value-adding competences
- and infrastructures in-house
- and on site with you.

3,500+
employees
worldwide

719.7
million €
turnover

6.4%
R&D
rate

1946
founded

100%
family
company

>100%
reinvestment
rate



Bürkert Fluid Control Systems

15 Columbia Way
Norwest Business Park
Norwest NSW 2153
Australia
Phone 1300 888 686
Fax 1300 888 076
sales.au@burkert.com
www.burkert.com.au