

# / Track & Trace

## Traceable Quality System



For **maximum protection** against **drug counterfeiting** along the entire **pharmaceutical supply chain**

# / TQS: the Optimal Modular System for Global Serialization Requirements

## Wipotec

### 4 Wipotec

All skills under one roof: globally acknowledged, independent, flexible and innovative

### 7 TQS – Traceable Quality System

The guarantee for process and product safety

### 8 TQS: combined expertise

For your custom application

### 9 TQS: intelligent systems

For more drug safety

### 10 TQS with ConfigureFast

Easy operations via a single interface

### 11 TQS: Open interfaces

For secure and dependable data transport

## Track & Trace systems

### 12 TQS-SP

User friendly serialization for use in small spaces

### 14 TQS-SP

Serialization solution for non erected cartons

### 16 TQS-HC-A

Serialization and weight inspection customized for your needs

### 18 TQS-HC-A with Tamper-Evident

Serialization, weight inspection, and Tamper-Evident labels for your product safety

### 20 TQS-BP

Simple aggregation of sets/bundles – flexible and format-independent

TQS-HC-A



**22 TQS-CP**

The perfect semi-automatic aggregation for shipment cartons and pallets

**24 TQS-Bottle**

Serialization for bottles and vials

**26 TQS-SP-Bottle**

Auxiliary code printing and ultrafast all round inspection of bottles and vials

**27 TQS-CP-Bottle**

Reliable 360° inspection for semi-automatic aggregation

**28 TQS-SP-RFID**

From plant to patient  
Safety through RFID

**30 OEM Components**

TQS for direct machine integration

---

## Service

**31 Reliable expert service**

Our expertise is at your disposal worldwide

---



TQS-Bottle



Wipotec Headquarters

# / **Combined Expertise Under One Roof** Cutting-edge Technology Made in Germany

Wipotec is a sales and service company for dynamic, high-precision weighing and inspection solutions. All machine solutions are developed and manufactured at our headquarters in Kaiserslautern, and we have been setting global standards in the production lines of leading manufacturers for more than 30 years. Throughout the world, customers in the pharmaceutical, food and chemical industries and in the mail and logistics sectors highly appreciate the solutions provided by Wipotec.

#### **Excellent solutions for your application**

Wipotec stands for sophisticated high-tech systems with maximum ease of use. The impressive product portfolio provides solutions for nearly all customer applications. If necessary, we take special requirements and conditions into account in supplying customized equipment.



**Extraordinary manufacturing depth, all side by side**

Wipotec contributes great importance to the in-house development of all necessary technologies as well as the in-house manufacturing of all core components. Consequently, we develop a depth of manufacturing that differentiates us from other vendors and makes us largely independent of suppliers, while forming the basis for our delivery reliability.

At Wipotec, the entire value chain from basic research, to planning, design, and manufacture to sales and service is all under one roof. The benefit of short channels of communication is the guarantee of maximum flexibility in the implementation of every individual product configuration. No matter how unusual your application may be, we will show you a possible solution that is sure to convince you. That's what makes the difference.



*A company  
must contribute to  
the well-being  
and advancement  
of society –  
not just  
short term  
but long term.*

**Theo Düppre**

Founder and CEO Wipotec Group





# / Globally Respected, Independent, Flexible, and Innovative: That is Wipotec.

## **More than 3000 Track & Trace projects worldwide**

Trust the professional industry experts at Wipotec with more than 3000 successfully completed Track & Trace projects worldwide. Our specialists will find the perfect solution for your requirements. We stand for top quality global serialization and aggregation.

- Globally respected partner in industry for more than 30 years
- Worldwide presence thanks to numerous subsidiaries and partners
- Founder managed company
- Company with high innovation power through large R&D effort, incl. basic research
- All expertise combined under one roof
- In-house production of all key components
- Broad product range for almost every application
- Broad experience in implementing customer-specific systems
- Use of high precision Wipotec weighing systems for optimum product quality
- Partner of GS1 and member of the Open SCS Working Group
- Outstanding service capabilities

## **Come and visit us!**

Interested in the high-tech solutions from Wipotec? Perhaps you would like to visit our ultra-modern plant. Our prominent market position is no accident, but rather the logical consequence of the creative and competent efforts made by our staff on behalf of our customers. Come and see for yourself. Just schedule an appointment for a tour with us!

### **Make an appointment:**

✉ [trackandtrace@wipotec.com](mailto:trackandtrace@wipotec.com)

# / The guarantee for process and product safety: TQS – Traceable Quality System from Wipotec

## **TQS Fast Track – full serialization and aggregation solution within 6 weeks\***

The Wipotec Traceable Quality System (TQS) is a series of modular, high-tech machines. TQS shortens the time needed to implement a fully automated pharmaceutical product serialization and aggregation packaging line. As a response to the impending EU FMD and the US DSCSA serialization deadlines, preconfigured TQS Fast Track machines are now available to enable healthcare companies to meet serialization and aggregation deadlines in the shortest time possible.

## **Easy and intuitive operator interface**

A single, user-friendly operator interface simplifies TQS machine setup and operation. The unique ConfigureFast feature enables visibility of all sub-components such as transport unit, printers and cameras via the operator interface's HMI screens. ConfigureFast significantly reduces human error, and machine setup times while increasing overall equipment efficiency.

## **Compliance with global serialization regulations**

The systems have all the attributes necessary to meet the legal requirements in the USA, European Union, China and other countries worldwide. The code layout software of TQS Fast Track includes relevant code layouts and application identifiers that correspond to global regulations. If country regulations change, the software receives relevant updates to guaranty unprecedented and fast compliance with emerging or amended Track & Trace regulations.

## **Efficient line management**

You can administer all production steps from serialization to pallet aggregation in one single system with the intuitive Line Manager Software. Thus, to operate the machine efficiently, it is not necessary to possess deep expert knowledge of the subcomponents or make an extensive investment in training and support of the operating personnel.

## **Accurate Printing and Verification at High Speed**

Integration of serialization equipment to the packaging line should not come at the cost of the overall line efficiency. All TQS machines including the Fast Track portfolio are equipped with highly accurate printing and verification technology to enable high product throughput of up to 300 pcs/min with the lowest possible product reject ratio.

## **Efficient data management**

Another unique feature of TQS and also Fast Track is the ability to go beyond serialization data and capture additional product attributes. These product attributes may include the weight and code quality. This additional data can be stored together with the product's unique serial number (TQS Traceability+)

## **Standardized communication protocols and interfaces**

TQS provides open XML and OPC UA interfaces. These ensure flexible connectivity with various "Level 3" providers throughout the entire production process. This interfaces enables the seamless exchange of data between production, warehousing, and enterprise systems. The usage of this universal interface eliminates the needing to change or re-validate line equipment if the higher-level system needs to be updated.

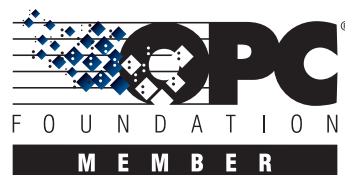

\* Period of six weeks commences with order acceptance and ends before FAT (Factory Acceptance Test)

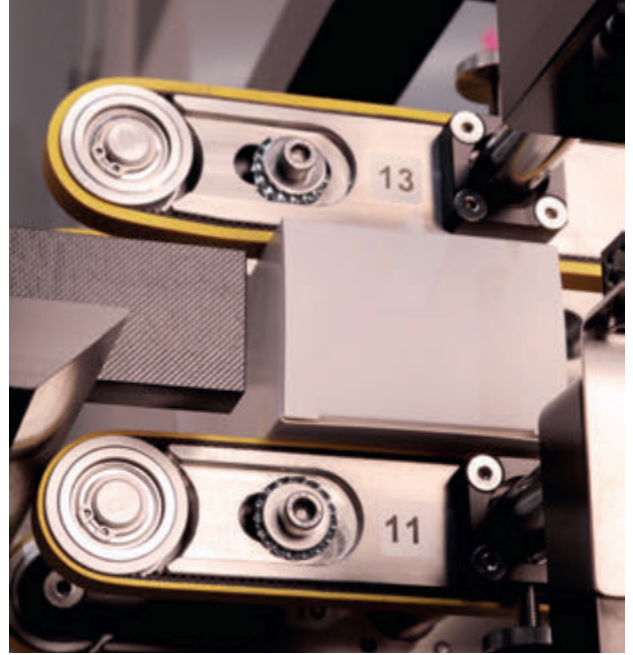

Stable transfer  
positioning of  
folding boxes for  
best print results

## / TQS: combined expertise for your custom application

Track & Trace begins with the right advice on how the TQS system implements country-specific regulations. On this basis, our project engineers work out the best possible machine and line configurations with you. They support you throughout the order processing and help later on, along with our service department, in the installation of your production lines. This approach ensures project and customer-specific requirements are met and, equally, respected for a timely project completion.

### High precision product transport ensures optimal print quality

Designed specifically for the TQS product series, the top belt features continuous height and width adjustments to ensure the safe transfer of the folding boxes and provide the necessary forced guidance. The sprocket belts for the conveyor are coated with a special, high grip rubber surface that provides optimal hold of the packages. Small tolerances are balanced in elevation of the boxes.

This construction eliminates slippage and movement of the packages during printing. In addition, this ensures highly accurate printing and verification, which can be increased even more with the aid of an optional synchronization sensor. All TQS machines feature high precision product transport, which enables extremely accurate coding even at a high throughput rate.

The safe transport of all packages is ensured by the time-tested NT belt technology, which also serves as the basis of high precision weighing. The use of proven modular systems facilitates the implementation of a very broad range of product dimensions.

### In-line grading

All TQS serialization machines (TQS-SP and TQS-HC-A) are designed with a function that checks the print quality of the printed codes in line. This control (grading) takes place continuously during throughput of the packages and is based on ISO/IEC 15415 (for 2D Codes) and 15416 (for 1D Codes).

This evaluation is a good indicator of the print quality and is useful as a trend indicator. In-line grading does not replace the full-scale, standardized verification of the printing results.



CIP: 4053213000004  
EXP: 01 2027  
LOT: 321TQS



GTIN: 04053213000004  
SN: 6585HR7C08XNA5D  
EXP: 01.01.2027  
LOT: 321TQS



### 药品追溯码

药品标识码:1234567  
序列号:1234567890123  
批号:123LOT123  
有效期至: 2024.05.24

请到XXXX扫码查询



# / TQS: intelligent systems for more drug safety

## **ConfigureFast: for quick and easy handling**

With flexible and intuitive operations thanks to ConfigureFast, TQS provides maximum ease of use. The transport system, coding unit, camera, scales and labeler are all controlled with a single software. This ensures convenient setups and short changeover times for the operator when switching products, as the usual irritating need to change to various user interfaces is eliminated. This consistency extends to all levels of aggregation.

## **Verification**

To comply with the applicable standards ISO 15415 (for 2D codes) and 15416 (for 1D codes) for offline verification of print quality (grading), we provide a code verifier. Depending on code geometry and dimensions, this can be selected and ordered as an application-specific option.

## **Tamper-Evident seals**

A key component in meeting European regulations regarding drug safety, is the application of a Tamper-Evident seal on every individual package. The serialization modules TQS-SP and TQS-HC-A use our very compact Tamper-Evident labeler to apply the safety seals. Our unique top belt system gives the necessary support to the packages.



*Wipotec makes  
a flexible  
and modular  
Track & Trace system  
that was perfectly  
customized  
to satisfy  
our needs.*

**Dr. Marco Klingele**

Track & Trace Program Lead/Head of Administration  
Losan Pharma GmbH

## **In-line thermo transfer printing of labels**

It is necessary in some applications to provide the individual packages with an additional, country-specific label or vignette. This step is also performed in the TQS-SP and TQS-HC-A machines by means of space-saving labeling units. There is an option of using thermal transfer printing facilitates, for example, the flexible printing of batch data.



Safe and dependable Tamper-Evident seals

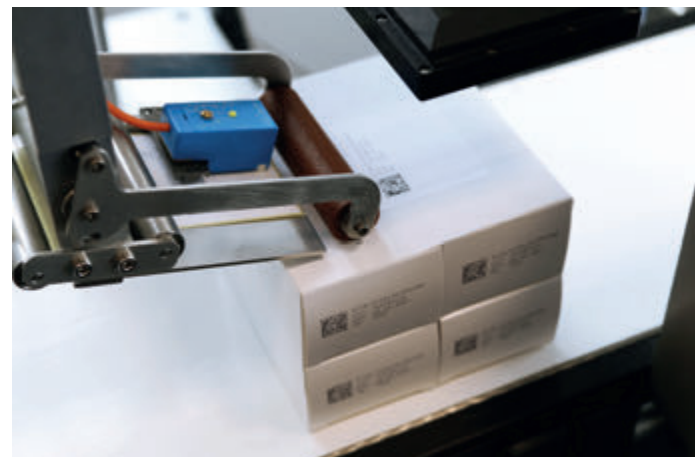

Maximum flexibility when printing country-specific labels

# / TQS with ConfigureFast: Easy operations via a single interface

TQS from Wipotec is the logical way to implement Track & Trace. The system is easy to use and, thanks to ConfigureFast, provides very impressive handling via a single user interface.

In TQS, ConfigureFast simultaneously generates content as well as print layout for the required labels. The print data is sent in parallel to the printer and to the image processing unit. This simple operation saves you the usual and sometimes complicated configuration of the various individual units. By means of the print data, the camera already has the accurate pixel information about the printed image. The user saves time by working in just one system, fully integrated and centrally controlled from a touchscreen panel display. The display gives a clear picture of extensive amounts of information. The user has everything directly in view and can interactively and easily make changes as authorized by the user rights.

ConfigureFast lets you operate and control either our thermal ink jet (TIJ), or the CO<sub>2</sub> laser printer, or the thermal transfer printer (TTO) for the labels. All of this means that it is very intuitive and easy to configure all of the TQS equipment.



*Aenova selected Wipotec as its Track & Trace System supplier because of the impressive technology, in particular, the very simple and easy to learn innovative operating concept. This results in extremely short set up times and, as a consequence, substantially higher productivity in the lines.*

**Alexander Pohl**

Technical Expert Packaging  
Aenova-Group



# /TQS: Open interfaces

## for secure and dependable data transport

No matter what your current IT structure looks like, you must always integrate the required or generated Track & Trace data. The following applies: The lower the number of optional modules to be installed, the better the system will operate.

TQS relies on the use of open XML and OPC-UA interfaces, avoiding the creation of any proprietary island solutions. The TQS Line Manager gives you the lowest possible IT overhead. The job order data can be input

directly into the machine. The Line Manager runs on any TQS module on the line and can easily and conveniently connect to a variety of Level 3 providers.

The core of the Line Manager is the production database which stores the data during the production operations. In the event of a temporary server and network infrastructure failure, the production line is secured by means of a local buffer memory. The permanent data storage is performed only in the Level 3 systems.

**Easy integration through a highly flexible software solution distinguished by open interfaces**

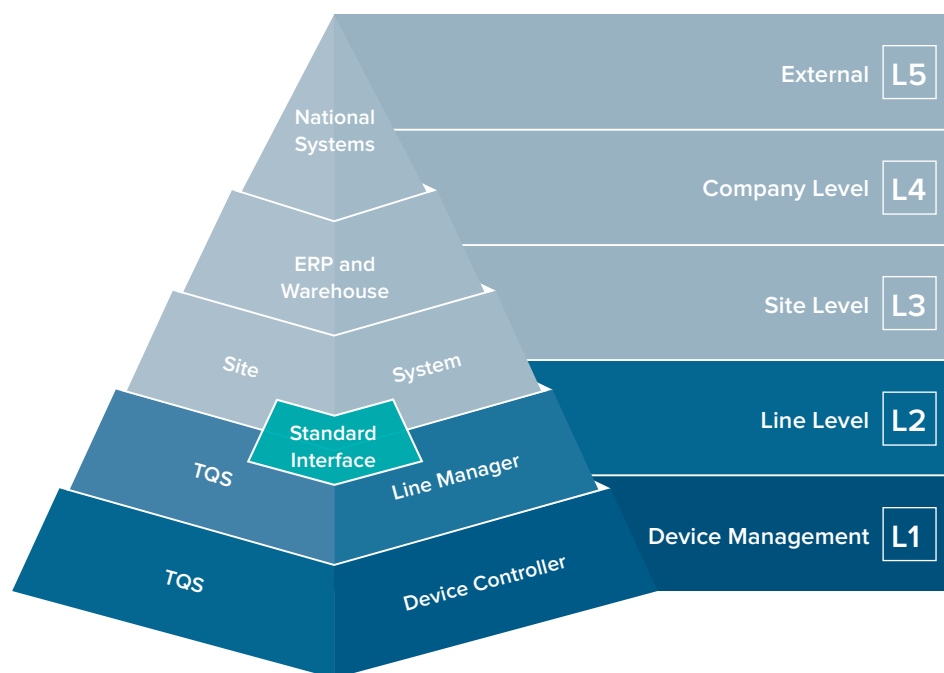

Wipotec is a solution provider to GS1 Germany and also a voting member of the GS1 Global Healthcare Solution Provider Network. We actively participate in joint ventures with the major pharmaceuticals and implement, the relevant targets and modifications regarding serialization and aggregation.



**Solution Partner**  
WIPOTEC GmbH

Wipotec is a member of the Open SCS Working Group. This indicates our commitment to flexible options for the integration in existing production infrastructures, as well as to the philosophy of open and standardized connections to higher-level systems.



# / User friendly serialization for use in small spaces

TQS-SP is a user friendly solution for the serialization of individual cartons. The folding boxes are conveyed by a specially designed, double guided top band system that ensures stable positioning after leaving the cartoner.

The TQS top bottom band is fully adjustable in three dimensions to quickly and easily accommodate various carton formats. The labels are applied as required on the flaps (front or back side) or the top of the folding boxes. The TQS-SP can be installed into a line network with automated product feed or as a mobile stand-alone unit with manual supply. The unit can be retrofitted into any existing packaging line.

Thanks to ConfigureFast, identical print data is sent directly to the printer and to the camera's print imager. All

system components are quickly and easily controlled from one single user interface without having to switch programs.

As an option for the TQS-SP, TQS-HC-A and TQS-BP, Wipotec supplies a fully automated grouping table that facilitates placing the folding boxes or bundles into rows in preparation for packing or even aggregation to the next higher packaging level (for example, shipment carton). The grouping table does not require any separate setup. It is controlled from the TQS machine.



## Main Features

- Stable transfer positioning of folding boxes and guided transport for safe and optimal printing and reading results
- TQS InkPrint printer with print head and fully integrated user guides
- TQS VIO1 camera with fully integrated user guides
- Flexible print head/camera mounting position
- Large 15" touchscreen display and intuitive control menu (19" optional)
- Validation packets and documentation IQ/OQ, FDS, RA, TM (optional)
- Tool free format change

## Your Benefits

- All-in-one operations concept for quick and easy handling
- High throughput rate of up to 600 pcs/min (300 pcs/min is standard)
- Space-saving unit for quick integration and operational readiness helps achieve cost reductions



Technical data	TQS SP
Material of machine	Stainless steel V2A/AISI 304
Unit weight	180 kg
Production type	IP54 <sup>1</sup>
Output	300 pcs/min (optionally 600 Stck/min)
Product length	30–200 mm (optionally 20–300 mm)
Product height	10–150 mm (optionally 10–200 mm)
Product depth	40–200 mm (optionally 80–300 mm)
Product transport height	800–950 mm (optionally 700–840 mm / 900–1.050 mm)
Rated voltage	L1/N/PE 100–240 V
Rated frequency	50/60 Hz
Connect load	1 kVA
Compressed air	Approx. 6 bar 16 NI/min, quality class 5/3/3 to DIN ISO 8573-1

<sup>1</sup> Water spray from above

These specifications are reference values of the standard machine excluding application- or weighing-specific add-on parts. Extended performance data available on request.

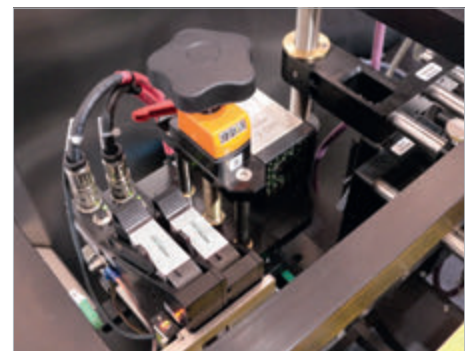

Highest grades when printing



Continuous authentication of folding boxes

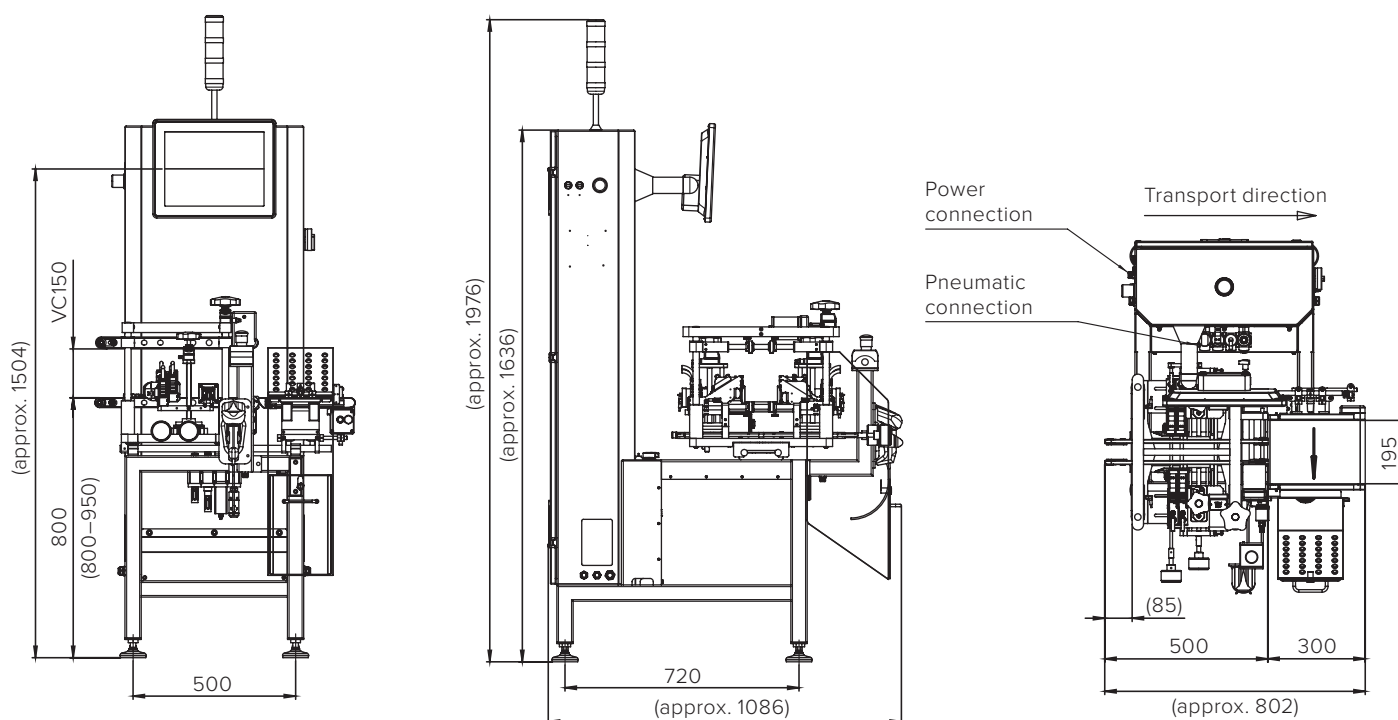

All entries in mm | Photo shows optional equipment

# /Serialization solution for non erected cartons

The TQS-SP for flat boxes from Wipotec was designed for offline coding and serialization of flat cardboard blanks used in folding boxes for pharmaceuticals. It enables cost-efficient serialization of small and medium batch sizes of pharmaceutical packaging that is to be pre-produced or hand-packed. As a centralized serialization solution, the TQS-SP is a welcome alternative for inline serialization of folding boxes on packaging lines with only low proportions of serialization or a high number of job changes due to small batch sizes. The TQS-SP is ready for use immediately without any integration effort.

Convenient set-up and short changeover times: With the ConfigureFast cross-system operating concept from Wipotec, a common software interface can be used to control layout, transport and printing system as well as camera-based real-time verification of code and text. The proven transport system reliably guides the cardboard blanks through the system even at high speeds, thus enabling consistently precise printing results of the highest quality and positioning accuracy. The camera system of the TQS-SP uses 100% product inspection to detect all the print characteristics of the processed products. Cardboard blanks with incorrect or illegible codes and texts are reliably ejected. The unit can process formats up to a width of 372 millimetres. Stepless format conversion when changing products can be carried out quickly. Successfully serialized cardboard blanks are transported to a stacker.

## Main Features

- Reliable transport of the non erected cartons due to a specially developed transport system
- TQS-InkPrint printing system with print heads and fully integrated operator guidance
- 100% correct printing results due to full-surface optical print verification
- Rejection of faulty products into lockable rejection bin
- Large 15" touchscreen display and intuitive control menu (19" optional)

## Your Benefits

- Cost-efficient serialization of small and medium batch sizes of folding boxes
- Centralized solution without on-site integration effort
- All-in-one operating concept for fast, easy handling
- High throughput: up to 250 cardboard blanks/min
- Large product range thanks to adjustable format changing position



Technical data	TQS SP
Material of machine	Stainless steel V2A/AISI 304
Unit weight	300 kg
Production type	IP54 <sup>1</sup>
Output	250 pcs/min
Product length	Up to 430 mm
Product depth	Up to 372 mm
Product transport height	800–950 mm (optionally electrically height adjustable)
Rated voltage	L1/N/PE 100–240 V
Rated frequency	50/60 Hz
Connect load	1 kVA
Compressed air	Approx. 6 bar 16 NI/min, quality class 5/3/3 to DIN ISO 8573-1

<sup>1</sup> Water spray from above

These specifications are reference values of the standard machine excluding application- or weighing-specific add-on parts. Extended performance data available on request.

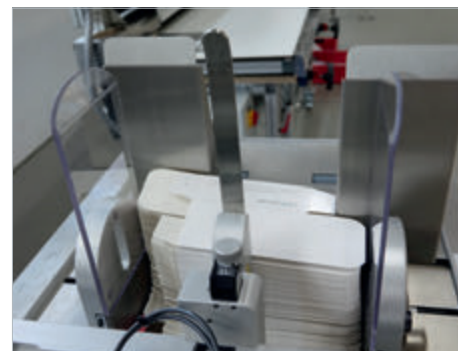

Stack processing of non erected cartons



Print process of the non erected carton

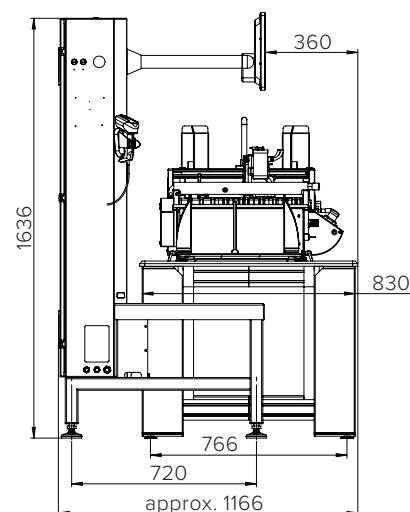
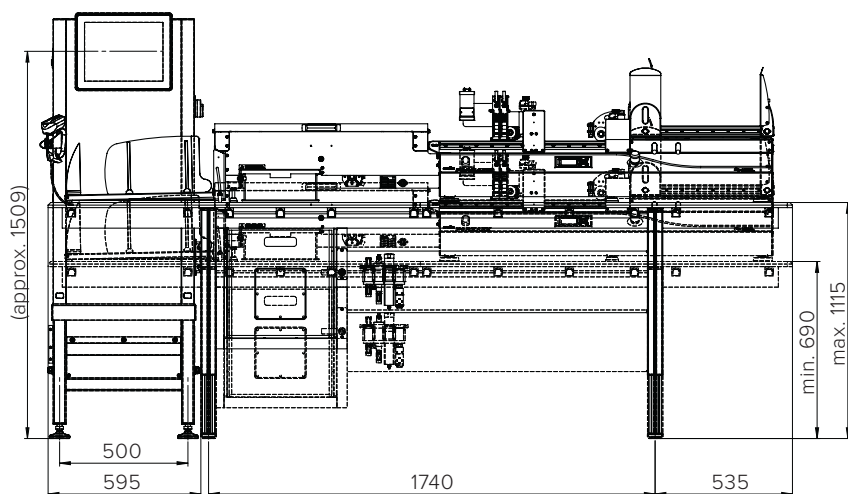

All entries in mm | Photo shows optional equipment

# /Serialization and weight inspection customized for your needs

TQS-HC-A continues the convenient features of TQS-SP in terms of product management and serialization, expanding them with a final completeness check by means of weight. Optional modules integrate the functionalities of our compact Tamper-Evident technology and country-specific vignette applicator.

The folding boxes are received from the upstream cartoner over a perfectly synchronized, adjustable top belt. This high precision product transport is the basis for smoothly guided coding and final verification. Products with faulty codes are discharged into a separate, lockable container in front of the weighing belt. Products with a faulty weight use a second ejection system directly behind the weighing belt.

Thanks to ConfigureFast, identical print data is sent directly to the printer and to the camera's print imager; all system components are quickly and easily controlled from one single user interface without having to switch programs. A more detailed description of the check-weigher component is provided in the HC-Avantgarde brochure.

As a supplement to TQS HC-A, Wipotec supplies a fully automated grouping table that facilitates placing the folding boxes or bundles into rows in preparation for packing or even aggregation to the next higher packaging level (for example, shipment cartons). The grouping table requires no separate configuration as it is controlled by the respective TQS machine.



## Main Features

- Stable transfer positioning of folding boxes and guided transport for safe and optimal printing and reading results
- TQS InkPrint printer with print head and fully integrated user guides
- TQS VIO1 camera with fully integrated user guides
- Flexible print head/camera mounting position
- High-tech Weigh Cells
- Large 15" touchscreen display and intuitive control menu (19" optional)
- Validation packets and documentation IQ/OQ, FDS, RA, TM (optional)
- Tool free format change

## Your Benefits

- All-in-one operations concept for quick and easy handling
- Compact, high-tech, multi-functional unit for optimal productivity
- High throughput rate of up to 600 pcs/min
- Maximal integration flexibility through modular design



Technical data	TQS HC-A
Material of machine	Stainless steel V2A/AISI 304
Unit weight	400 kg (with Tamper-Evident 600 kg)
Production type	IP54 <sup>1</sup>
Output	300 pcs/min (optionally 600 Stck/min)
Weighing range	Up to 750 g (optionally up to 1.500 g)
Product length	30–120 mm (optionally 20–220 mm)
Product height	10–150 mm (optionally 10–200 mm)
Product depth	40–200 mm (optionally 80–300 mm)
Product transport height	800–950 mm (optionally 700–840 mm / 900–1.050 mm)
Rated voltage	L1/N/PE 100–240 V
Rated frequency	50/60 Hz
Connect load	1 kVA
Compressed air	Approx. 6 bar 16 NI/min, quality class 5/3/3 to DIN ISO 8573-1

<sup>1</sup> Water spray from above

These specifications are reference values of the standard machine excluding application- or weighing-specific add-on parts. Extended performance data available on request.

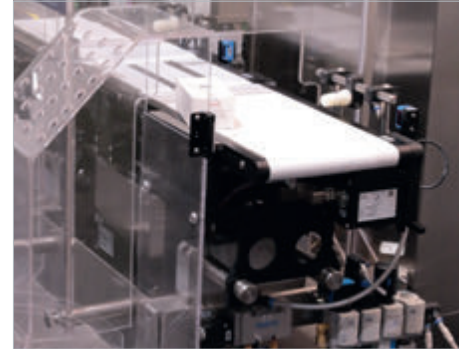

Dependable ejection of faulty containers

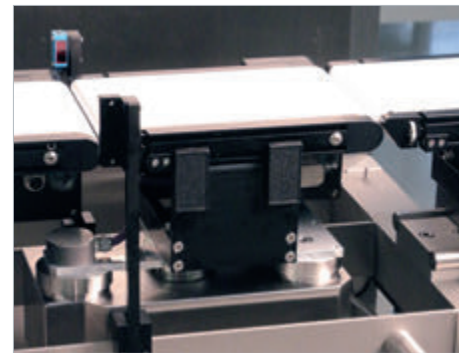

Wipotec Weighing Technology – High precision weighing with EMFR Weigh Cells

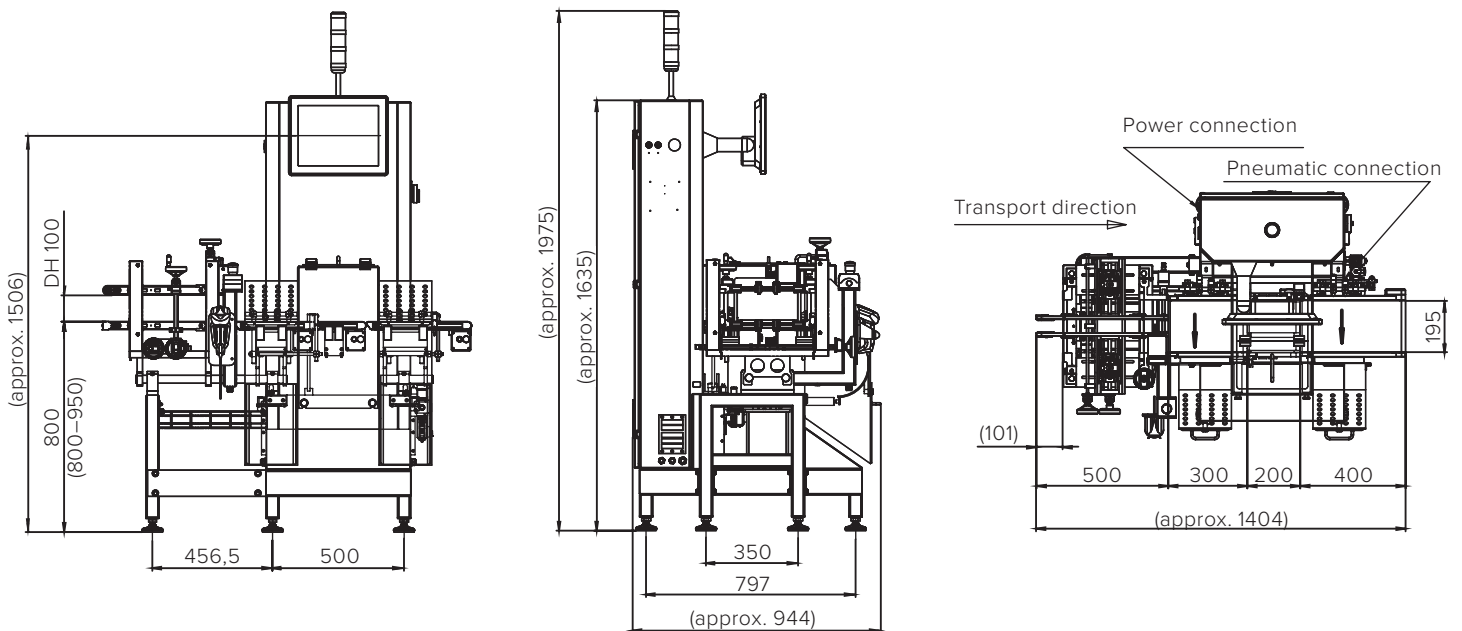

# /Serialization, weight inspection, and Tamper-Evident labels for your product safety

TQS-HC-A, equipped with Tamper-Evident labeling systems on both sides, allows you to serialize the folding boxes, to verify the print, to seal the insertion flaps with Tamper-Evident labels, to apply vignettes, to discharge products according to diverse sort rules, and to determine the weight – all during throughput operations.

Country-specific labels or vignettes are applied by means of compact labeling units. Alternatively, the system can also be equipped with optional thermal transfer printers to print in-line batch or serialization data. What this means for you: All foreseeable regulations

regarding serialization worldwide can be met with just one space-saving and user-friendly machine.

Optionally TQS-HC-A can be ordered with full enclosure. This guarantees the security of the process route; no operator can intervene in the ongoing process while the machine is operating. The replacement of consumables for printer, vignette or tamper-evident applicators, including all machine settings, can be carried out from one side only, which makes operation easier, especially when dealing with line integration.



Products with faulty coding are ejected ahead of the weighing belt into a separate lockable container. Products with a faulty weight use a second ejection system directly behind the weighing belt. The intuitive operation of all components is conveniently and centrally organized in a single interface. This means that all system components are directly, quickly, and easily controlled by a single software interface, without any program changes.

Five functions (serialization, Tamper-Evident seal, vignette labeler, additive label printing, weighing) in one unit are what make TQS-HC-A the most compact serialization machine worldwide. Easily integrated as a space-saver in the tightest production environments, it also has an outstanding price performance ratio in comparison with individual components.

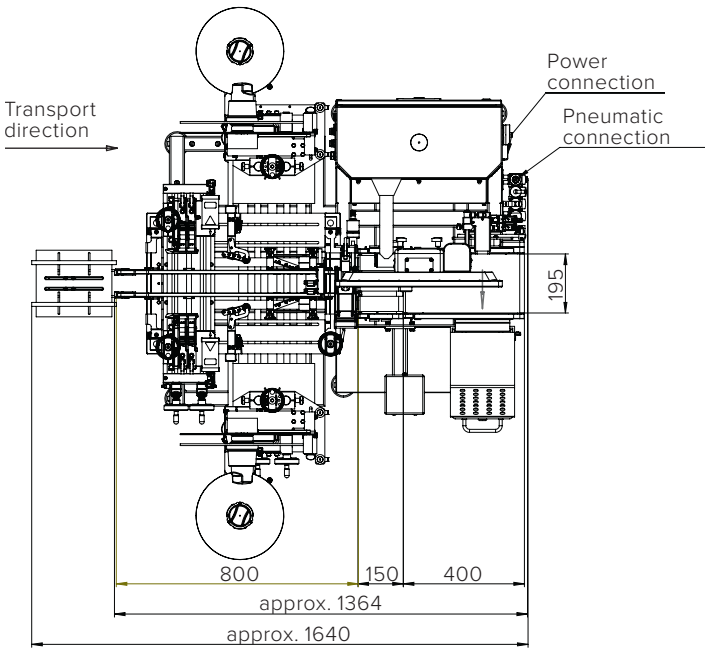
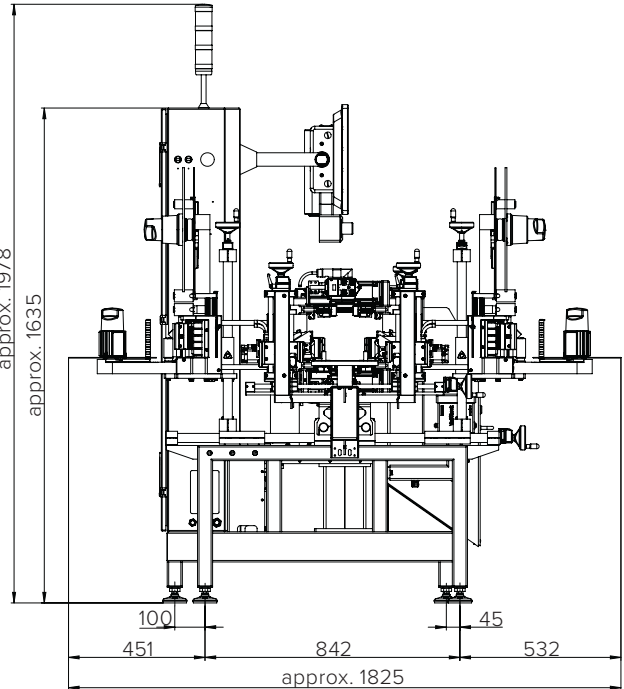
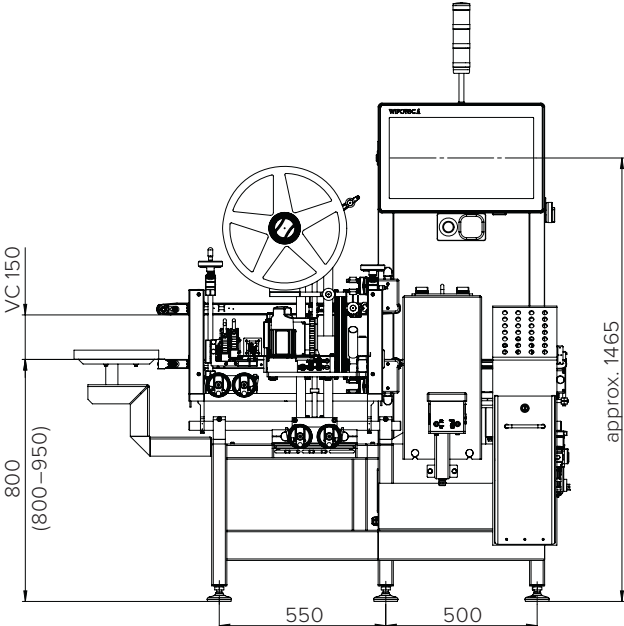

All entries in mm | Photo shows optional equipment

# / Simple aggregation of sets/bundles – flexible and format-independent

TQS-BP is perfectly equipped for the simple implementation of the first aggregation level. The system enables the serial numbers from multiple single packages to be combined to form one unique serial number for the set.

The model has a format independent transport and reading system. The bundles are received directly from the bundler or, can also be manually introduced. The machine's intelligent code ID provides optimal flexibility, even with any eventual variations in geometry.

Regardless of whether the packaged sets are rounded by stretch wrapping, shrink wrapped, or fully over-wrapped, they can be reliably and safely read by means of the optional UV camera.

As a supplement to TQS-BP, Wipotec supplies a fully automated grouping table that facilitates placing the sets or bundles into rows in preparation for packing or even aggregation to the next higher packaging level (for example, shipment cartons). The grouping table requires no separate configuration as it is controlled by the respective TQS machine.



## Main Features

- Fully integrated label printer and applicator unit, incl. camera control
- High Performance TQS VIO2 camera for precise code verification
- Handheld scanner for manual read in and changing aggregation hierarchies
- Reliable discharge by means of the traction pusher
- Large 15" touchscreen display and intuitive control menu (19" optional)
- Validation packets and documentation IQ/OQ, FDS, RA, TM (optional)
- Camera mounts front and back (optional)
- Tool free format change

## Your Benefits

- All-in-one operations concept for quick and easy handling
- Space saving design facilitates integration in existing lines
- High throughput rate (up to 90 pcs/min, 30 pcs/min standard) enables significant increase in productivity



Technical data	TQS BP
Material of machine	Stainless steel V2A/AISI 304
Unit weight	210 kg
Production type	IP54 <sup>1</sup>
Output	30 pcs/min (optionally 90 Stck/min)
Product length	30 mm (optionally to 350 mm)
Product height	10–200 mm
Product depth	40–200 mm (optionally 80–300 mm)
Product transport height	800–950 mm (optionally 700–840 mm / 900–1.050 mm)
Rated voltage	L1/N/PE 100–240 V
Rated frequency	50/60 Hz
Connect load	1 kVA
Compressed air	Approx. 6 bar 16 NI/min, quality class 5/3/3 to DIN ISO 8573-1

<sup>1</sup> Water spray from above

These specifications are reference values of the standard machine excluding application- or weighing-specific add-on parts. Extended performance data available on request.



Professional labeling with TQS-BP

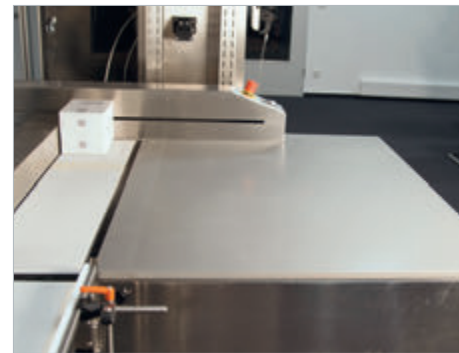

Option: fully automated grouping table

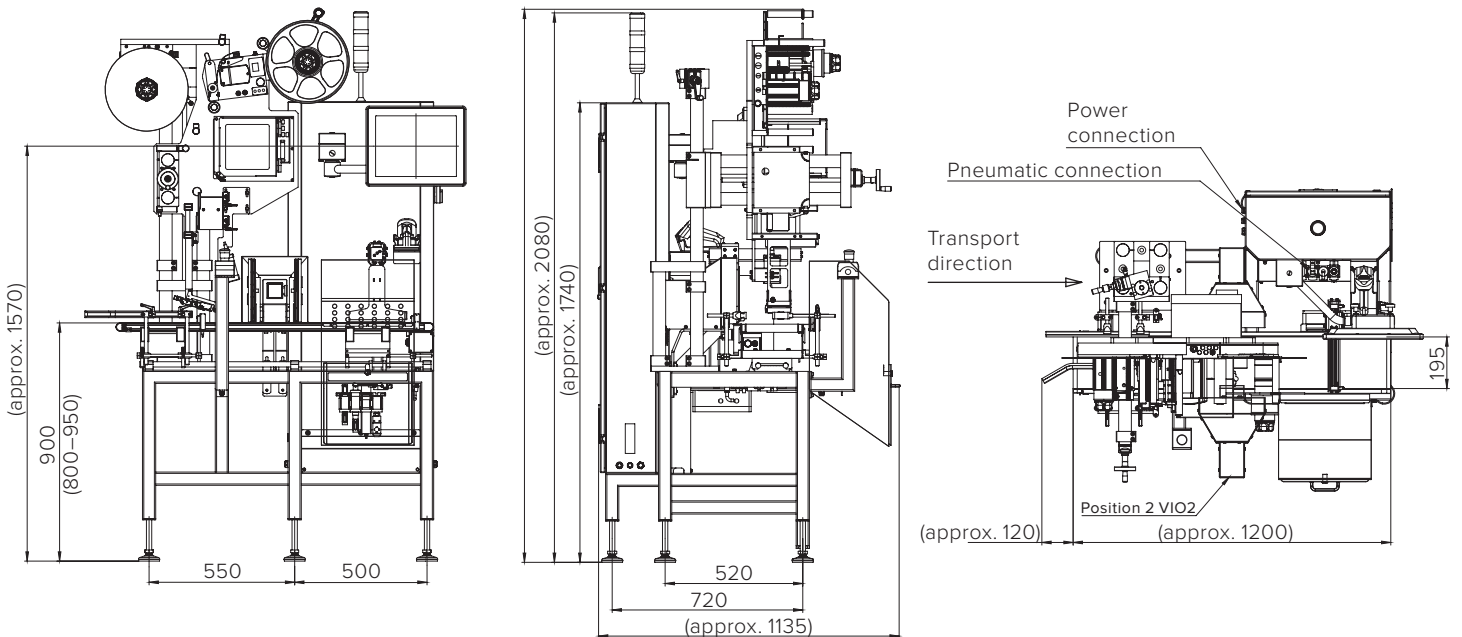

# / The perfect semi-automatic aggregation for shipment cartons and pallets

TQS-CP stands for the successful semi-automatic aggregation of manually repacked folding boxes. It lets you conveniently assign units from a lower level (folding box or bundle) to a higher packaging level (shipment carton).

The operator places the packaged units layer-by-layer in the shipment carton. Each completed layer is then photographed from above by the fully integrated camera. The camera automatically moves to the preset height for packing in order to always ensure the proper

focus distance. After the defined number of layers and units has been reached, the aggregation level is completed and a label is automatically generated.

TQS-CP also manages the next packaging level (for example, shipment cartons on pallets). The aggregation of the pallet can be performed in parallel with the TQS-MP option – even fully integrated as TQS-MP-EXT version. The operator is supported by the integrated display on the mobile scanner.

## Main Features

- Industrial scale labeler on adjustable height table
- State of the art camera for multicode-reading from above and fully integrated operator guidance
- Large 15" touchscreen display and intuitive control menu (19" optional)
- Ergonomic design with adjustable product table height
- Validation packets and documentation IQ/OQ, FDS, RA, TM (optional)
- Weighing platform (optional)
- Tool free format change

## Your Benefits

- All-in-one operations concept for quick and easy handling
- Safe and reliable aggregation of every single product
- Greater value from one machine for the aggregation of shipment cartons and pallets (optional)



Technical data	TQS CP
Material of machine	Stainless steel V2A/AISI 304
Unit weight	280 kg
Production type	IP54 <sup>1</sup>
Product dimension (W×D×H)	600×400×550 mm (optionally 840×560×550 mm)
Product table height	500–800 mm adjustable
Rated voltage	L1/N/PE 100–240 V
Rated frequency	50/60 Hz
Connect load	0,8 kVA

<sup>1</sup> Water spray from above

These specifications are reference values of the standard machine excluding application- or weighing-specific add-on parts. Extended performance data available on request.



High resolution camera for full surface images



Optional: TQS-MP-EXT for pallet aggregation

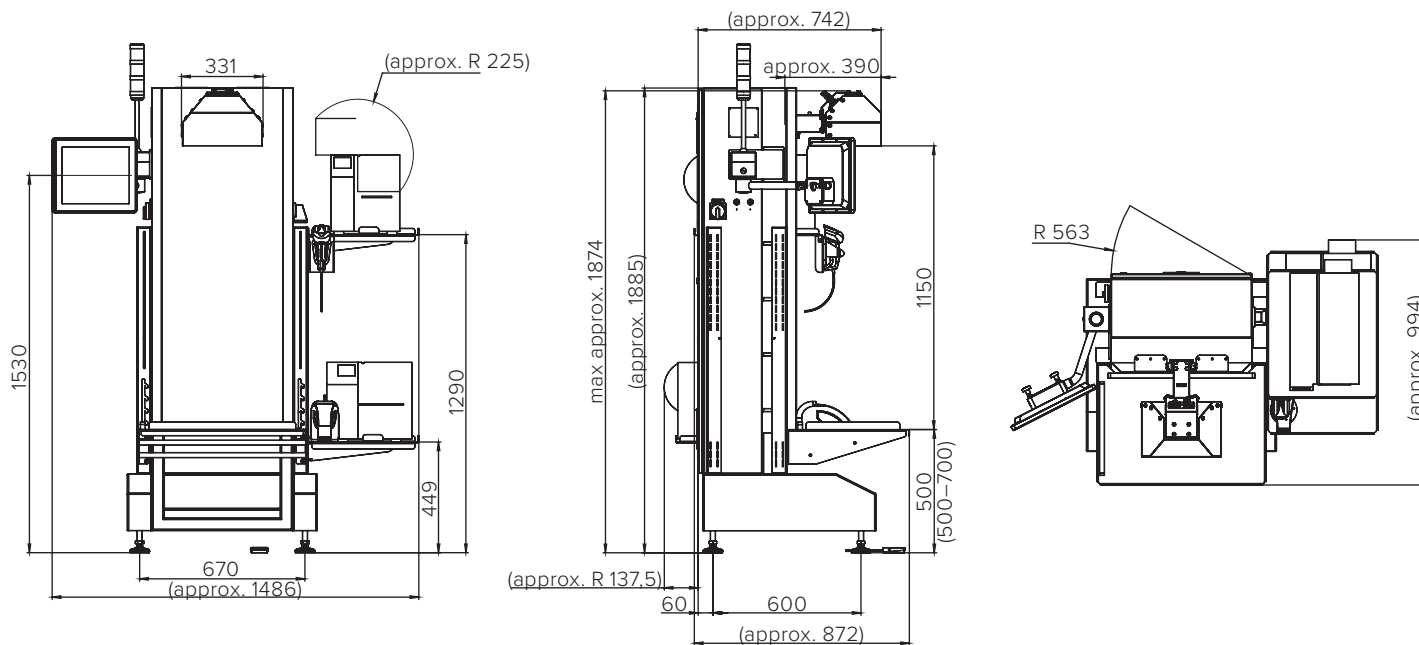

All entries in mm | Photo shows optional equipment

# /Serialization for bottles and vials

The TQS-Bottle from Wipotec serializes medicine bottles at high transport speeds. Serialization is carried out simply by applying labels to the bottles. The compact, space-saving footprint of the TQS-Bottle combined with a very short design in the direction of product flow makes it easily integrated into existing lines. Labelling is carried out in a star wheel with format-specific pockets

or a driven lateral side grip conveyor. If necessary, the system can respond to product-specific requirements with the aid of format parts. A thermal printing system ensures high-resolution printing of the labels with plain text and product codes.

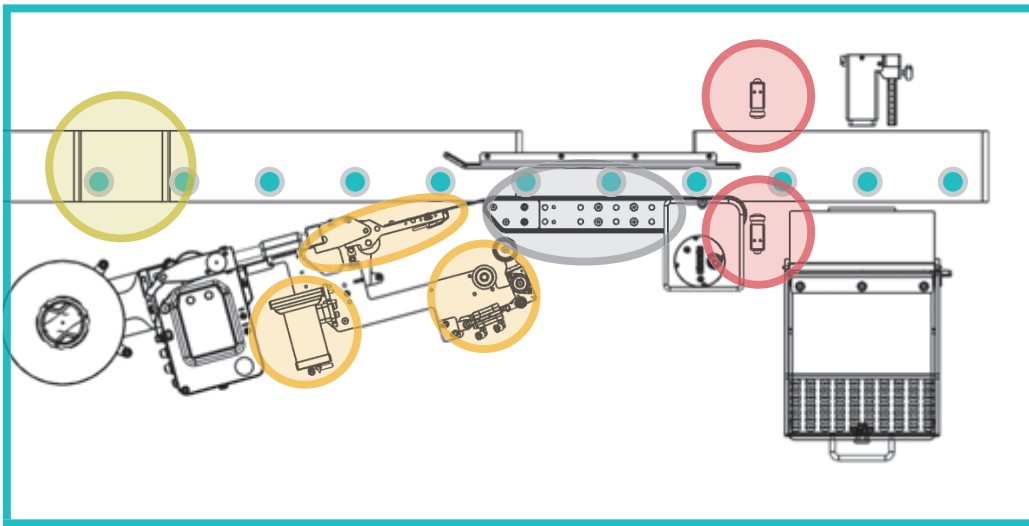

## Main Features

- Safe product transfer due to modular construction, different versions possible
- Thermal transfer printing system for high-resolution printing of plain text and product codes
- 100% correct labels due to full-surface optical print verification
- Ejection of faulty labels
- Return of unlabelled products to the process
- Large 15" touchscreen display and intuitive control menu (19" optional)
- Can be optionally equipped with precision weighing system

Printer, camera, conveyors, checkweigher, ejection and all other modules are fully integrated into the system. Therefore they are aligned and controlled via one central HMI.

Dedicated infeed and handling modules allow applying labels with maximum precision, especially on not perfectly even glass containers.

Fully integrated checkweigher

The camera checks each label before application. This enables the system to eject labels with faulty print or wrong information. Products therefore only receive 100% verified and correct labels.

Application belt handles various product dimensions without format parts.

Unlabeled products will be recognized and rejected for rework.

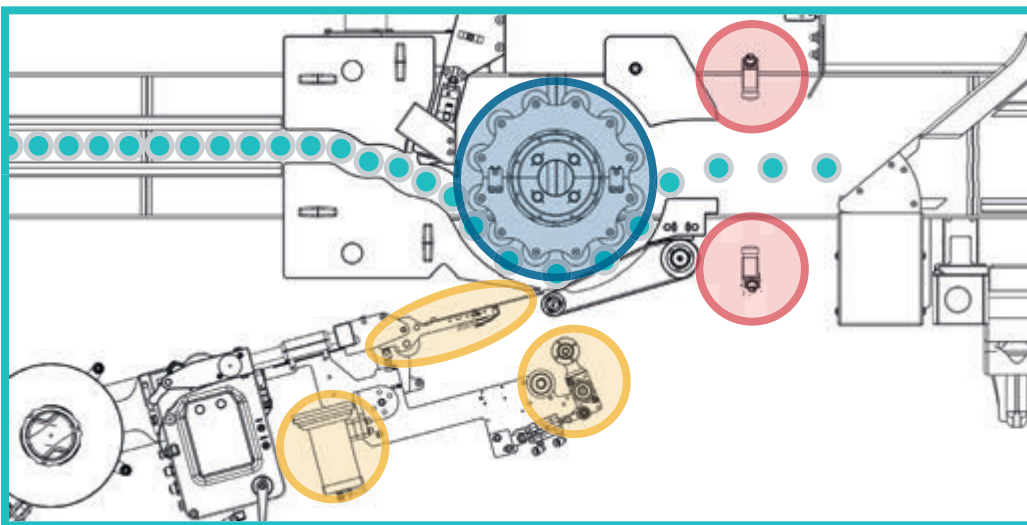

## Your Benefits

- All-in-one operating concept for very quick and easy handling
- Space-saving design for easy integration into existing lines
- High throughput
- Large product range due to modular configuration





# / Auxiliary code printing and ultrafast all round inspection of bottles and vials

TQS-SP-Bottle prints auxiliary codes and verifies bottles and vials. Printing is completed by the CIJ printer either on the underside or the top of the container (visible only under UV light, if required). Subsequently, the machine verifies the previously serialized bottle or vial labels.

The auxiliary aggregation code is for the higher-level aggregation in bundles or cartons. Additionally the integrated 360° camera unit manages the all round inspection of cylindrical objects, for example, the optical control of the coding, layout, and plain text on vials or bottles. Multiple ultrafast cameras are used for the omnidirectional detection of the objects.

Coded containers with faulty labels or an incorrect auxiliary code are separately ejected from the product flow and stored in lockable containers.

ConfigureFast will quickly and easily configure all sub-components, like the printer and camera, from a single interface.

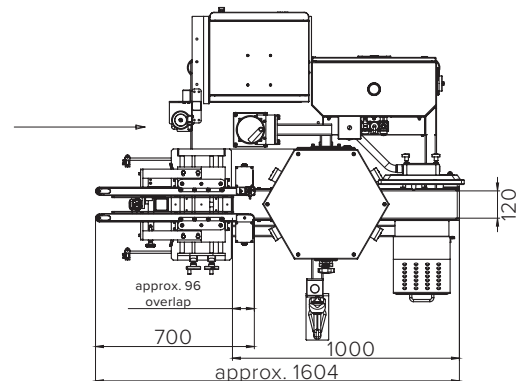
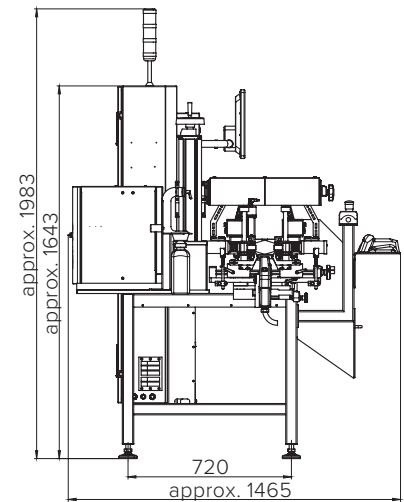
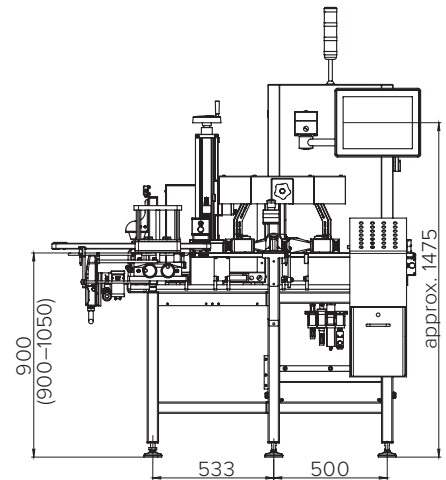

All entries in mm | Photo shows optional equipment

# / Reliable 360° inspection for semi-automatic aggregation

TQS-CP-Bottle is designed for the perfect integration in bottle or vial production lines. The system can be set up directly at the outlet of any conventional labeling machine to verify the previously serialized labels on individual cylindrical containers via an omnidirectional, 360° inspection. This is done by a 360° camera, which features a central adjustment unit to facilitate the tool free adjustment of all cameras to the respective diameter of the bottles.

Bottle-shaped products are transported to the machine via a conveyor screw. The codes of previously serialized products are identified in a 360 degree process. A non-readable or invalid serial number leads to its discharge. A fully automated grouping table facilitates placing the products into rows in preparation for packing or even aggregation to the next higher packaging level (for example, shipment carton). The grouping table does not require any separate setup. It is controlled from the TQS machine. Once the carton is full, the operator applies the automatically printed label to the shipment carton and verifies it with the handheld scanner.

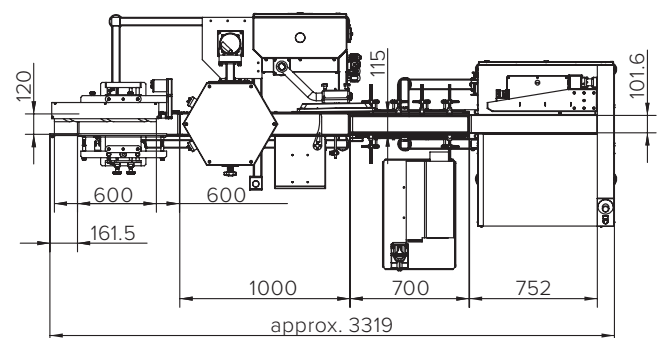
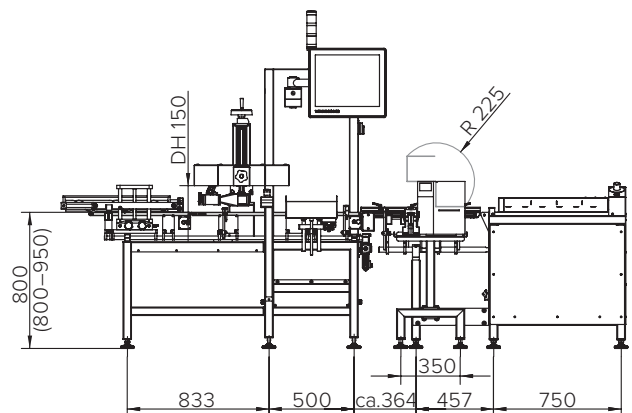
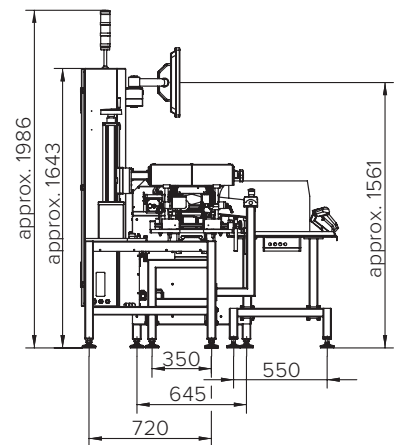

All entries in mm | Photo shows optional equipment

# / From plant to patient

## Safety through RFID

### Traceable Quality System

Healthcare facilities are in the process of establishing RFID technology as a standard. RFID allows mix-up control, prevents drug diversion and enables producers, facilities and staff to keep track of medication on vial and dose level. This challenges pharmaceutical manufacturers to support this trend. The Traceable Quality System performs the required tasks – in its typical user-friendly way.

The TQS features a Continuous Inkjet printer to mark the caps with a human-readable code or text. As the content of the marking is entered via the central control, printer and camera receive the same information. Therefore, the camera checks the print in the next step without an operator having to touch it.

The RFID unit also is a fully integrated part of the system. It therefore automatically receives the same data as the printer and camera, which it then can either write into a tag or read out data that has already been written in an earlier process step.

### Main Features

- CIJ printing code or text on cap
- 100% print control
- RFID writing and reading

### Your Benefits

- One system
- One user interface
- One contact
- One service partner
- Unlimited options



### Made for vials

Handling, transporting and sorting glass containers with a small diameter requires special attention. The TQS is equipped with precisely tailored modules to handle them in the most careful way. It therefore guides the vials through the entire process without any risk of falling over or even damage.

In addition to the verification unit for the print, the system features a top-camera to check the cap colour of each vial. By ejecting incorrect ones, it prevents mix-ups, which otherwise would result in time-consuming rework and costs.

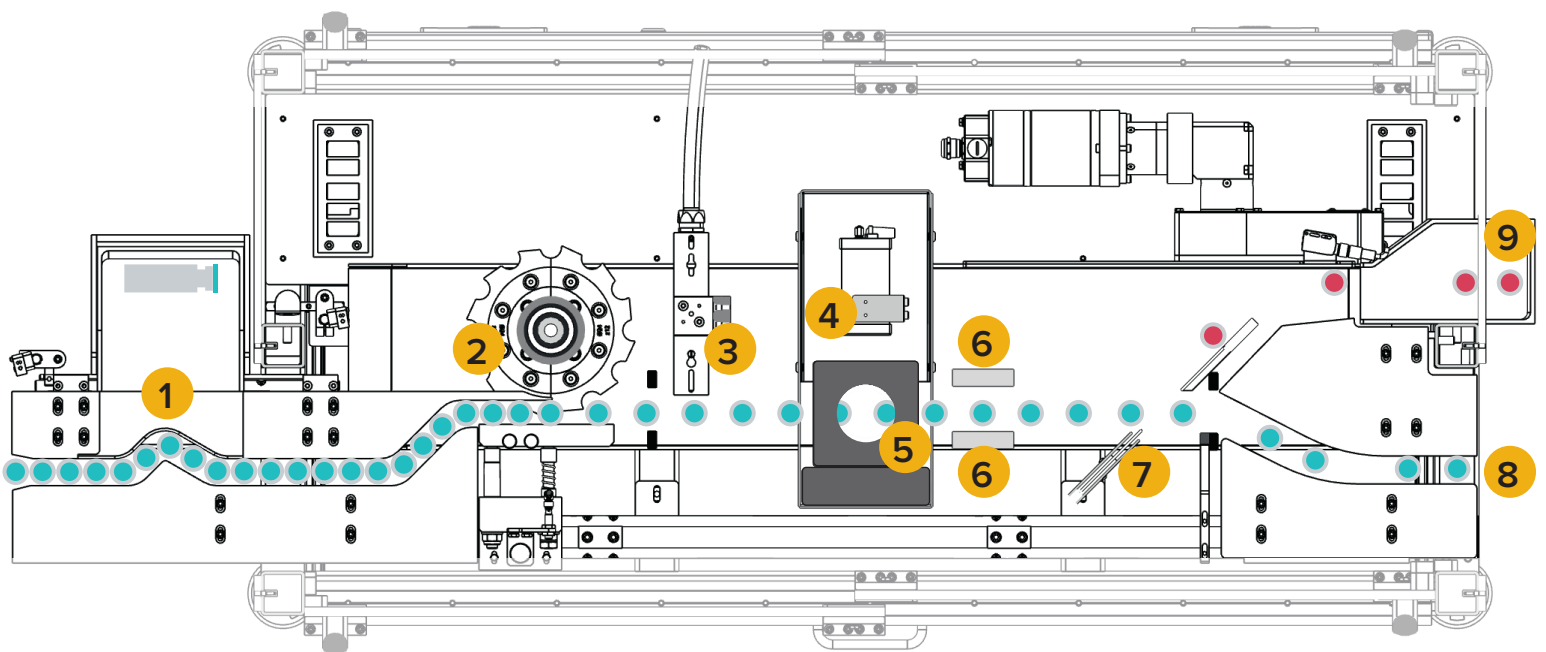

1. Ejecting tumbled vials
2. Separation station
3. CIJ printer
4. Side camera for CIJ verification
5. Top camera for cap color verification

6. RFID antenna
7. tumble-free ejector
8. good channel
9. bad channel

- Vial
- Vial rejected

# / OEM components: TQS for direct integration

## OEM kits for maximum flexibility

In addition to the independent machine components of the TQS series, we also supply components for the direct integration in packaging machines. These options modules are given the “OEM” designation. TQS-OEM Kits and their functional ranges correspond to those of the separate machines. Consequently, the TQS-SP-OEM for serialization is integrated in the cartoner. Similarly, TQS-CP-OEM for fully automated aggregation of shipment cartons is placed directly in the end-packaging machine.

## Space saving integration

The TQS integration variants are especially practical if the existing installation conditions do not offer adequate space. Both variants may also be used in mixed operations. That creates space for your other individual requirements. The integration of these components generally requires the cooperation of the equipment manufacturer because it always involves plant-specific installations.

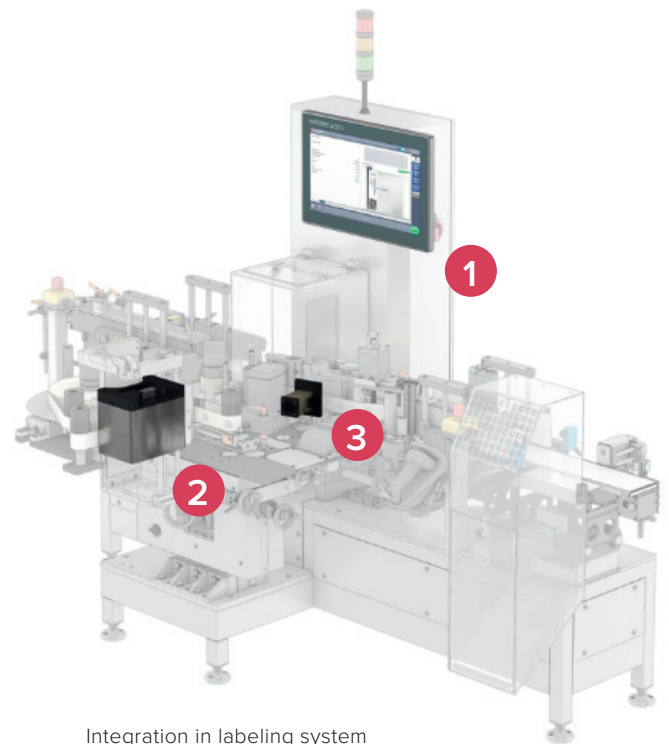

Integration in labeling system

1. One HMI for central control
2. Thermal transfer printer (TTO) for marking labels
3. Fully integrated camera to verify the print

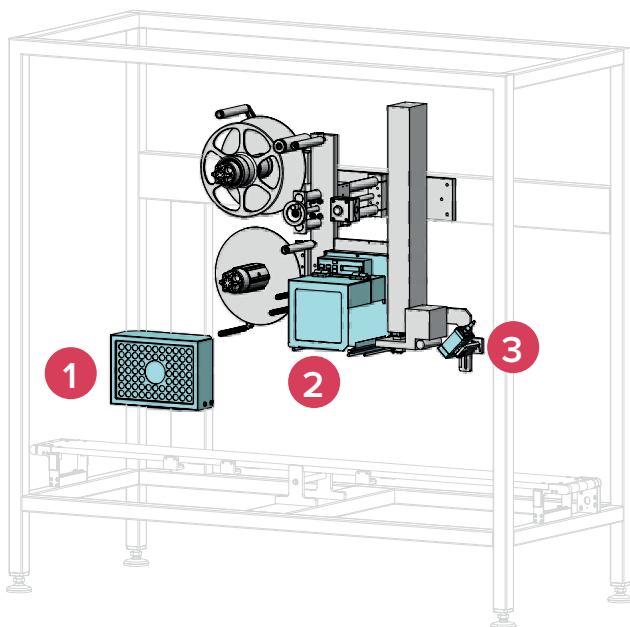

Integration in case packer

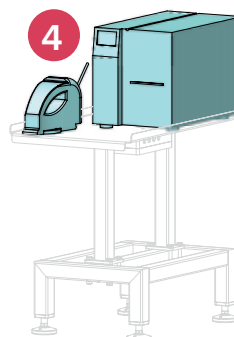

1. TQS-VIO3 camera for layer-by-layer reading of full surface data at case-packing level
2. Thermal transfer printer for shipment carton labels
3. TQS-VIO verifies shipment carton labels
4. Wireless handheld scanner incl. integrated control panel with industrial scale thermal transfer printer for labels



# / **Reliable Expert Service,** Customized to Your Needs

When you choose Wipotec as your system supplier, you have the benefit of top quality service modules that incorporate the vast experience of our weighing and inspection system experts. Whether a pure consulting service or specific line and product support throughout the product life cycle, we are your reliable partner.

Turn to us with your requirements. We would be pleased to discuss the scope and effort of individual services in more detail with you. Trust in our experience and reliability. ▲



## Benefit from our **outstanding range of services**

- 24/7\* – Hotline availability
- Global service network with certified technicians for on site support
- Professional installation and optimization based on customer needs ensures smooth start-up
- Europe-wide conformity assessment and complete overhaul with the exchange of verification relevant parts
- Preventive maintenance, setup, and optimization of your systems
- Fast on site repairs using original parts
- Calibration checks and readjustment of the entire system, if required
- General product and target objective training to improve efficiency
- Remote maintenance first hand (with appropriate hardware) for urgent jobs

\* On conclusion of a corresponding service agreement

# Raise your production to the next level:

fast, cost-saving,  
and profitable!

## Contact us!

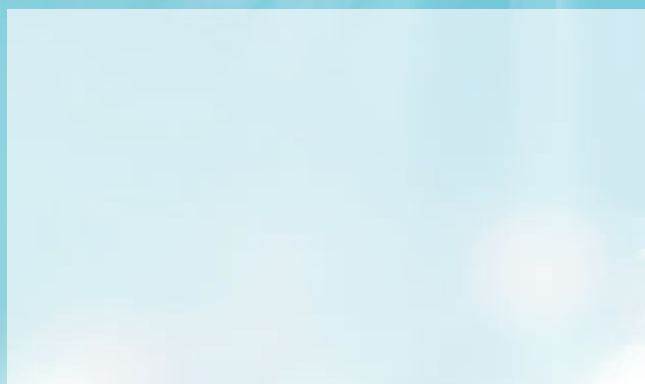

### Headquarters

WIPOTEC GmbH  
Adam-Hoffmann-Str. 26  
67657 Kaiserslautern  
Germany

T +49 631 34146-0  
F +49 631 34146-8690  
info@wipotec.com  
wipotec.com

**WIPOTEC** 