

A quick tour around the D-Series

intelligent Technology

i-Tech components combine to create a system altogether more flexible and reliable.



Optional intuitive remote TouchPanel

Industrial connectors and detachable conduit for easier installation and servicing

Controller module that can be hidden under the production line, or rack mounted to save space

Full-length integrated mounting rails on each side for easy positioning

Energy efficient temperature controlled fan cooling

Compact i-Tech Scan head with flexible mount for head rotation in 90 degree steps

Compact footprint design and small head gets into tight spaces

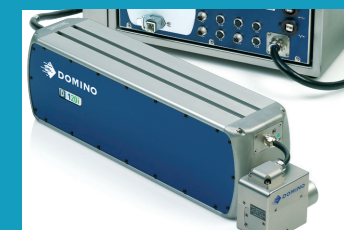

IP65 option for more protection



New i-Tech RapidScan coding technology for ultra fast performance



Our next generation of primary coders deploy our unique intelligent Technology system, i-Tech. Our aim was to make production lines lower maintenance, lower cost and more efficient. i-Tech has helped us to achieve that aim.



Technical specification

	D120i	D320i	D620i
Laser Type	CO ₂	CO ₂	CO ₂
Laser wavelength	10.6µm 9.3µm for blue tube	10.6µm 9.3µm for blue tube 10.2µm for red tube	10.6µm 9.3µm for blue tube
Laser power class	10W	30W	60W
Coding Features	Coding speed Fonts & texts Graphics & logos Machine readable codes Code content Focal length/coding field i-Tech ¹⁰ Focal length/coding field i-Tech ¹⁵		
	Supports high-speed applications* Laser optimised fonts for high-speed marking incl. standard fonts, multi-language, and unicode. *.bmp (monochrome), *.plt, *.dxf More than 60 types of barcodes, 1D and 2D codes. Supports GS1. Supports traceability coding with serialisation data. Configurable date, counter, and time format. 80mm/58x58mm, 100mm/68x68mm, 120mm/84x84mm, 150mm/102x102mm, 200mm/136x136mm, 250mm/180x180mm 250mm/200x254mm, 325mm/262x334mm, 450mm/356x452mm		
Dimension & Weight, Integration	Laserhead cooling Laserhead dimension (LxWxH) Laserhead weight Controller IP Controller dimension (LxWxH) Controller weight Integration		
	Air cooled (IP20) Compressed air cooled (IP65) (IP20) 681x140x180mm (IP65) 776x140x180mm (IP20) 16.7kg (IP65) 17.7kg	Air cooled (IP20) Compressed air cooled (IP65) (IP20) 776x140x180mm (IP65) 870x140x180mm (IP20) 22.8kg (IP65) 23kg	Air cooled (IP20) Water cooled (IP65) (IP20) 846x173x180mm (IP65) 946x140x180mm (IP20) 27.3kg (IP65) 30kg
Environment	Operating temperature Operating humidity Power requirements Power consumptions		
	5°C - 40°C / higher temperatures on request max. 90% RH, non-condensing 90-264V, 47-63Hz max. 1050VA max. 1050VA max. 1440VA		
User Interface & Software	User interface Marking software		
	Graphical user interface (GUI), WYSIWYG entry, TouchPanel (optional) Control language is configurable in over 25 languages. QuickStep2 including Dynamark4		
Inputs & Outputs, Interfaces	Product detected inputs Line speed detection Signal inputs/outputs Interfaces		
	NPN/PNP/24V-sensor Shaft encoder (differential) or steady signal (single-ended signal) Multiple inputs and outputs available from controller e.g. fume extractor, compressed air kit, water chiller, encoder, product detect, beacon and interlocks. Output signals provided for coder ready, coder busy, compile OK and coding done. Additional inputs available for laser start, coding control and programmable logic. RS232, EtherNet (10/100 Mbit), USB, EtherNet/IP™ (optional)		
Options	Aiming beam, user port kit I/O, fume extraction shroud, USB image backup/restore kit, daisy-chaining, i-Tech RapidScan technology (only with i-Tech ¹⁰ scan head), OPC DA, EtherNet/IP™, pharma option, 4-colour beacon		
Accessories	Rack mounting kit, laser stand, fume extraction system		
Application certification	Marking: CE, cTUVus / Fulfills requirement: ROHS, FDA listed, EMC, FCC		

*Substrate, pitch and code dependent. Please consult your local sales agent

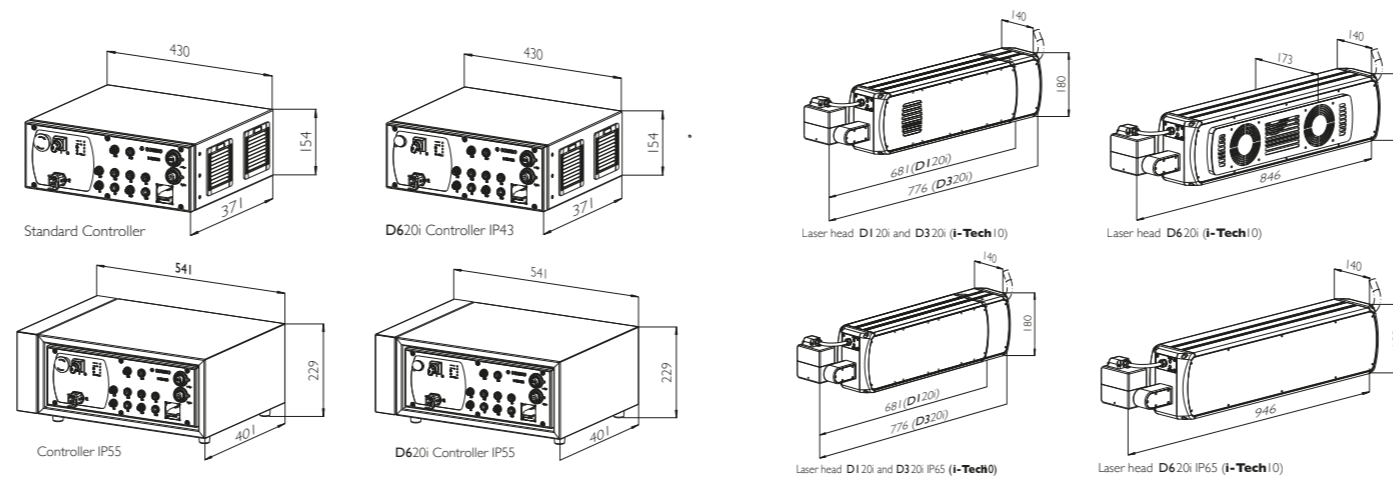

Domino D-Series Lasers

Small things can make a big difference



The latest editions of our successful compact scribing laser are designed to fit in even the smallest of spaces.

www.insignia.com.au

DS/0521UK All performance-related figures and claims quoted in this document were obtained under specific conditions and may only be replicated under similar conditions. For specific product details, you should contact your Domino Sales Advisor. This document does not form part of any terms and conditions between you and Domino.

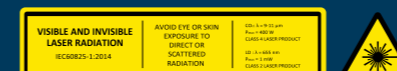

Domino. Do more.

Domino D-Series – new, compact lasers are flexible in more ways than one.

The new i-Tech scan head is smaller and adjustable, allowing the D-Series lasers to be installed in the most restricted spaces.

A new IP65 version design adds greater protection for harsh environment installations.

Flexible connectivity and a familiar interface now make it possible to control D-Series lasers from anywhere.

Improved performance at high line speeds through the patented optional i-Tech RapidScan technology.

A diverse range of applications

The D-Series laser system produces unlimited lines of text in any orientation, and in many fonts and sizes. It is equally suitable for both graphics and 2D datamatrix codes. All are permanently applied to a wide range of materials from low to high production line speeds.



High code quality ideal for 2D datamatrix coding



Special lasers for clear codes on PET and PP materials plus a special scan head option for larger web coding applications



High quality at highest line speeds



Greener credentials

Domino's commitment and investment in sound environmental practices means we frequently exceed the demanding governmental, industry and company standards and regulations. We are committed to minimising the consumption of natural resources and energy and the creation of waste. Wherever practical our products are RoHS and WEEE compliant so that they are recyclable.

D-Series

The new D-Series, with no need for inks or solvents – minimising waste as well as 20% reduced weight (versus previous models) – helps you to reduce your carbon footprint. Automatic temperature controlled fan cooling means the coder saves energy whenever applications allow.

More flexibility – simplifies integration



Compact

Fit is a big issue, so we've gone small. We've also separated the components to create a modular design, making the D-Series laser easy to install. It simply adapts to your production line set-up.

Flexible

The key to the D-Series flexibility is a smaller i-Tech scan head, connected to the laser tube on a multi-position mount. The head can be rotated through 90 degree steps to allow for many mounting positions, and because it is so much smaller, it can easily fit where bigger lasers cannot.



Easy to install

Full length integrated mounting rails on both sides of the laser head and its smaller overall footprint makes the D-Series an easy and safe installation.

More convenience – saves time

Accessible

As an operator, you can manage the coder by either our intuitive remote TouchPanel or via its web-based interface from any industrial PC. For the ultimate in flexibility, the D-Series can also be controlled via your production line interface.

QuickDesign Lite - Simplifying

If you would like to create your laser coding message from a remote PC D-Series offers QuickDesign, a single, easy to use Windows® application. It also lays the foundation for providing increased automation of your coding needs.



Easy to operate

D-Series i-Tech uses QuickStep, our unique simplified operator user interface for effortless control and status reporting. No complex menus or parameters, just enter the job and away you go.

- Large user friendly icons and customisable home screen for quick access
- Intuitive 3-tiers menu structure makes QuickStep WYSIWYG message creation and editing quick and easy to learn

More protection – enhances reliability

Built to last

An optional IP65 version adds protection to the laser tube while not compromising on overall size. Its aluminium and stainless steel construction gives you lasting performance in the harshest environments.

Peace of mind

The robust controller is the ultimate in reliable equipment. It stores message data without the need for a hard drive, minimising the number of moving parts in the whole system. It can also be hidden under the production line, away from the laser, or rack mounted to save space and reduce the likelihood of accidental damage.

Secure

Our pharma option offers unique user passwords and change reporting to be 21-CFR part 11 and GAMP compliant. This can be supplied and installed with validation packages to ensure that systems are tested and proven to the highest standards.

D-Series also ensures legally compliant solutions to cover the serialisation requirements of the European Falsified Medicines Directive (EU Directive 2011/62/EU) with both human readable and 2D datamatrix coding.



More performance – increases efficiency

Faster without compromise

The i-Tech scan head is the fastest scan head of its kind – resulting from its optimised mirror and software control plus the revolutionary patented i-Tech RapidScan technology.

RapidScan makes our lasers 20% faster for high-speed applications than other scribing lasers as D-Series can track the product for longer by using the optimum configuration of the mark field.

Versatile performance

The new D-Series offers a power range of 10W, 30W and 60W lasers to fit all your coding needs, from low to high speed applications, basic to complex codes, and for all production environments. There are two scan head options available for different application requirements, with the i-Tech 15 scan head offering exceptional code quality on larger mark field applications, e.g. for coding on the web.

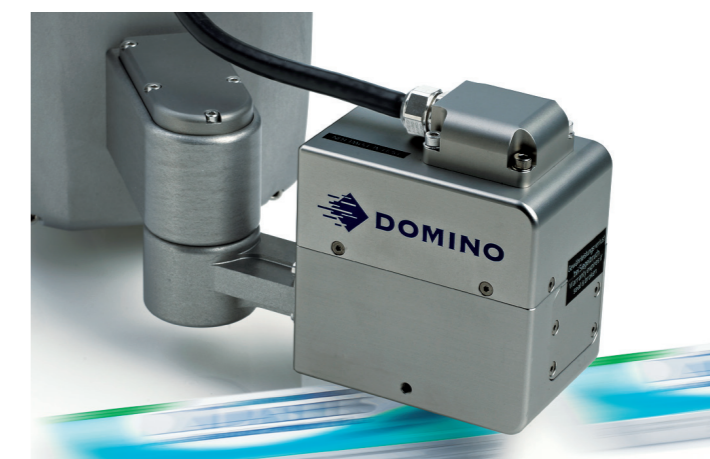

DPX Fume Extraction
The Domino DPX Fume Extraction range integrates with D-Series and provides a simple solution.

The new i-Tech RapidScan also improves the ability of D-Series to code difficult to mark materials and to print longer or more complex codes where more energy or time is required to scribe the code.

D-Series delivers results where other scribing lasers have already reached their limit.

