



Watch the gripper in action.

Motopal Gripper Series

Patented by RA and specifically designed to handle shelf ready cartons in a multitude of sizes and quantities



General purpose and shelf ready carton gripper for palletising solutions.

Shelf Ready Cartons are one of the hardest products to palletise in most production facilities and are becoming even more difficult as the trend moves to reduce carton support even further.

Shelf Ready Cartons vary in size, shape, weight and have wide range of perforations, being tray packed or capped types resulting in minimal product and vertical support that can cause cartons to fail, resulting in spilling and damaging contents during the palletising process. High speed palletising of shelf ready cartons using “conventional standard grippers” can fall short of the task required.

Designed and built exclusively by Robotic Automation, the proven Motopal Gripper Series has been created to handle virtually any type of carton including shelf ready cartons on your production line. With the ability to pick up multiple cartons every cycle it can achieve a rate of up to 40 cartons per min*.

The MOTOPAL-780 has the flexibility to allow multiple sized products to be palletised in the same production line.

Matched with the Motoman GP180, the MOTOPAL-780 Gripper is a highly efficient fully servo gripper perfect for both end of line and multi robot centralised palletising applications.

Key Benefits

- A fast, flexible and powerful package with small footprint
- Reduction of damage to cartons
- Pre-programmed for most patterns and carton sizes
- Simple to edit
- Low cost palletiser infrastructure
- Easy to install and simple to maintain
- Offline programming via “MotoLogix” on a PLC of your choice
- Designed for use with Embedded AGV's.

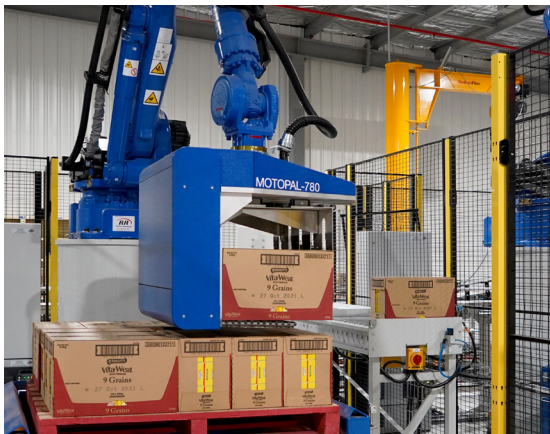

Example of shelf ready product cartons.

MOTOPAL GRIPPER SERIES (Patented)

	MOTOPAL-1120	MOTOPAL-780	MOTOPAL-380
Total Weight	130kg	120kg	60kg
Suitable For	GP130	GP130	GP100 OR MPL80
Product Weight	30kg - 50kg	20kg - 30kg	12kg
Max. Product Length	500mm	500mm	350mm
Max. Product Height	345mm	345mm	300mm
Max. Product Rate*	40cpm @ 5cpc	24cpm @ 30cpc	16cpm @ 2cpc

*NOTE: Max. Product Rate depends on the average # of cartons per robot cycle. ie. 5cpc (cartons per cycle) @ 8cpm (cycles per min) = 40cpm

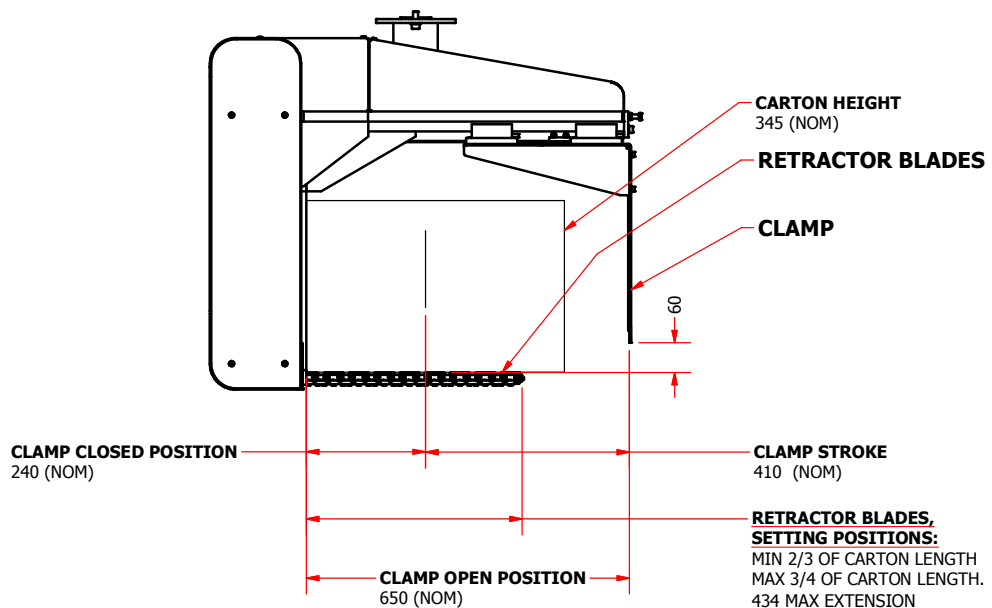
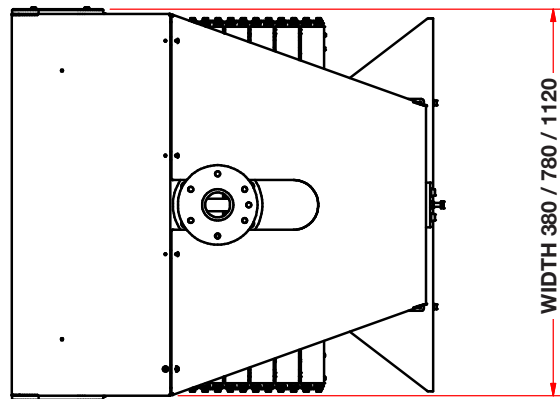

Robotic Automation p/l

14/4 Avenue of Americas
Newington, NSW 2127
Australia

Tel. 1300 552 333
sales@ragroup.com.au
www.ragroup.com.au