



方舟工業有限公司  
CFL INDUSTRIES SDN. BHD.

(418268-T)

www.cfl.com.my

**EDGE PROTECTION & PAPER PALLET Solutions**

**REUSABLE, RECYCLABLE OR DISPOSABLE**



**BENEFIT OF USE**

- Air freight   - Electronics   - Export   - In-store display
- Food & Beverage   - Pharmaceuticals   - Trade Display



PAPER PALLET



FLEXI GUARD  
EDGE PROTECTOR



EDGE PROTECTOR



PERSONALIZED PRE-PRINTED  
EDGE PROTECTOR

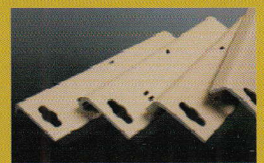

DIE-CUT EDGE PROTECTOR  
2 IN 1 USAGE



WEB : [www.cfl.com.my](http://www.cfl.com.my)

TEL : 604 - 508 7100 / 7010 / 7001

EMAIL : [cfl@cfl.com.my](mailto:cfl@cfl.com.my) / [sales@cfl.com.my](mailto:sales@cfl.com.my)

FAX : 604 - 508 7801 / 7802

ADDRESS : 780 (PLOT 144), LORONG PERINDUSTRIAN BUKIT MINYAK 11, TAMAN PERINDUSTRIAN BUKIT MINYAK, 14100 SIMPANG AMPAT, SEBERANG PERAI TENGAH, PENANG, MALAYSIA.

# WHO ARE WE

[www.cfl.com.my](http://www.cfl.com.my)

CFL Industries Sdn Bhd was established in 1997. Today, we are the leading manufacturer and exporter of edge protector (corner board). At CFL, we are not merely an edge protector manufacturer, we have the ability to have your products tailored to your requirements and designs. As an experienced manufacturer, we make every effort to provide our clients, whether domestic or international with exceptional quality edge protectors.

Excellence in quality and efficiency are our goal; this means we will have to go "that extra mile" to prove our credentials. Being an experienced manufacturer of edge protection products, we are committed to efficient manufacturing process along with stringent quality control program which has earned us the accreditation of ISO 9001 in year 2002. That knowledge and experience, together with our aggressive team, ensure that our goals are met.....quality and efficiency.

Environment conservation is highly regarded at CFL. Only non-hazardous, RoHS-Compliant and recyclable materials are used. Our total commitment to environmental management system is evident and we have been awarded with Sony Green Partner Program (SS-00259) since 2003.

Our edge protector are widely used in various industries such as the agricultural industry, electronics industry, furniture industry, machinery industry and more. CFL's clients expand all over the world. Our products are exported to Singapore, Hong Kong, Japan, New Zealand, Australia, Indonesia, Thailand, Canada, South Africa and Vietnam.

You can be assured that the best quality product can be obtained through CFL. Through a governed quality management system, we mandate for excellence and pledge to provide our clients with products and services that exceed their expectations.

## CFL COMPANY MILESTONE

- 1997** — CFL was founded in Sungai Petani Light Industrial Estate, Kedah, Malaysia, with the built-up area of 3,500sqf. CFL started off with manufacturing of Edge Protector (Angle Bar), as well as trading of other packaging products such as Tapes, Stretch Film, and Strapping Band.
- 1998** — Exported our Edge Protectors to Hong Kong and Singapore. Included Slip Sheet as our trading products.
- 2001** — Moved to Juru Light Industrial Estate Penang, Malaysia with the built-up area 12,000sqf to fulfill market requirements. Export business was extended to Japan, New Zealand, Australia, Indonesia, Thailand and Vietnam. Added Packaging Machines and Shrink Films to the product list.
- 2002** — Obtained ISO 9001 : 2000 (CERT NO: 2337 - UKAS).
- 2003** — Successfully established an Environmental Management System that has met the requirements of the Sony Green Partner Program (SS-00259).
- 2004** — Factory built-up area was extended to another 12,000sqf with the total of 24,000sqf.
- 2006** — Range of product was extended to printing Stretch Film, POF (sheet and bag form) and paper pallet.
- 2008** — In line with our business growth, added 2 production lines and 1 Tape Cutting Machine. Developed Printed Edge Protector and Moisture Coating Edge Protector.
- 2009** — Upgraded to ISO9001:2008 (CERT NO: 2337 - UKAS).
- 2010** — Obtained Industrial Design for A Module Pallet (MY09-00640-0101). Filing Patent Application for A Pallet (PI 2010000227) and A Laminated Article (PI 201000026). Relocated to Bukit Minyak Industrial Estate, Simpang Ampat, Penang, Malaysia with 52,440 sqf.
- 2011** — Successfully obtained "Authorized Distributor 3M Industrial Adhesives & Tapes Division" for Northern Region of Malaysia.
- 2014** — Upgrade 1 unit of new Edge Protector machine invest one POF cutting line. Obtain Patent for Pallet with reinforced runner (PI2014703084)
- 2015** — Upgrade a more unit of new Edge Protector machine and invest one unit of Runner Making Machine.
- 2017** — Invest one paper core making line.

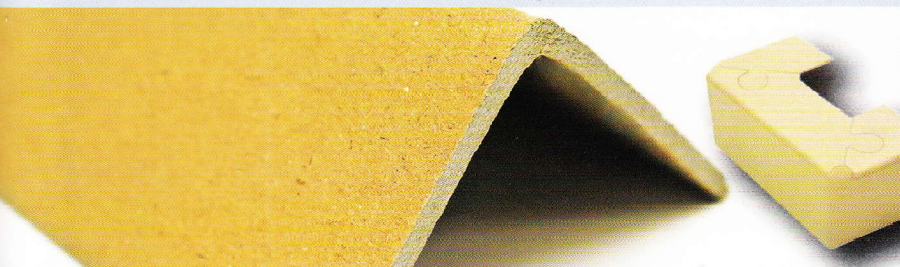

# CFL PAPER PALLET

comes in wide range of sizes and forms to suit any application. We make every effort to provide our clients with exceptional quality paper pallets:

**100% RECYCLABLE**  
**COST EFFICIENT**  
**FULLY CUSTOMIZABLE**

**FUMIGATION FREE**  
**RoHS - COMPLIANT**  
**ISO 9001:2008**

## DESIGN

CFL paper pallet combines the best quality in the followings:

- Light weight, easily carried by one person
- 100% Recyclable
- Strong, heavy duty payloads
- Clean and easy to handle
- Fumigation Free
- Own assembly for export customer



## TEST CONDITION

- Temp 30°C RH 75%

## RAW MATERIAL

- Core Board Paper
- Cold based water soluble glue

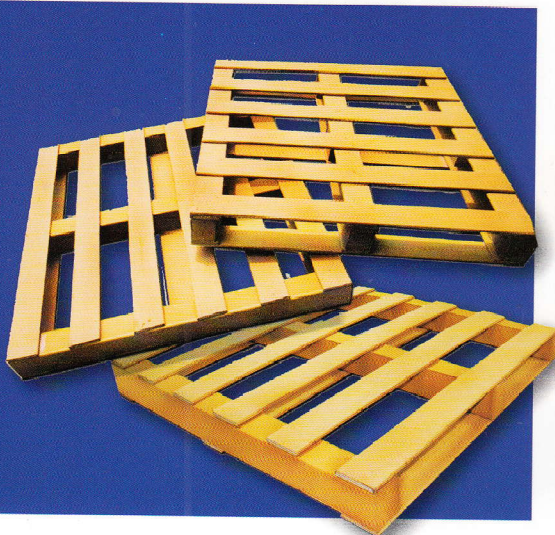

## SPECIFICATION

MODEL: 2 WAY & 4 WAY PAPER PALLET

Size (mm)	Weight (KGs)	Payload / Dynamic (KGs)
1100 x 1100	11 KG	300 - 1000
1000 x 1200	11 KG	300 - 1000

**Customizable**

**2 ways paper pallet**

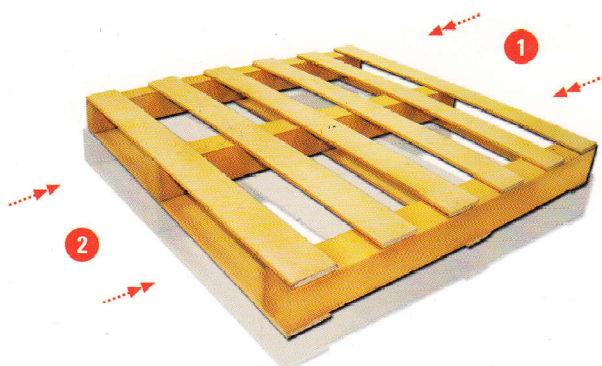

**4 ways paper pallet**

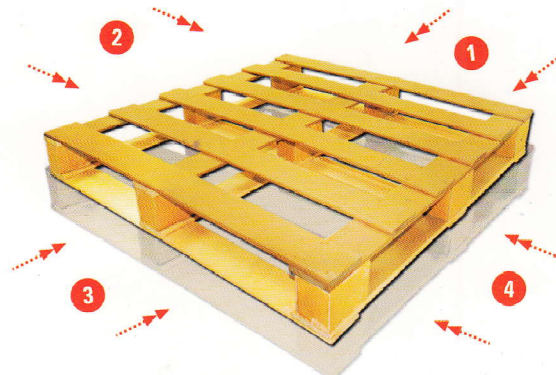



# OUR PRODUCTS EDGE PROTECTION

[www.cfl.com.my](http://www.cfl.com.my)

| Continual quality improvement | Fast and timely delivery | Lasting customer relationship |

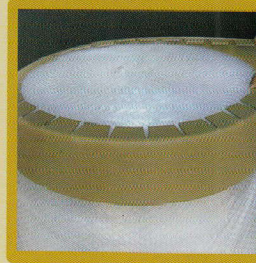

**FLEXI GUARD**  
Flexible Alternative  
For Rounded  
Shipment

Ensures proper handling of loads and keeps oil / grease in place without affecting the shipment.

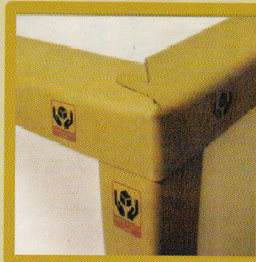

**CORNER GUARD**  
Cost Effective  
Corner Protection

Precisely die-cut for product protection. Effectively avoid costly damage in shipment and storage.



**EDGE PROTECTOR**  
Eliminates Load  
Shifting And Slipping

A smart alternative to make the pallet stronger for double stacking. And provides extra bracing when stacking pallet.

## PERSONALIZED PRE-PRINTED EDGE PROTECTORS

CFL realized the packaging challenges during shipments and transits. That's why we have the ability to create and pre-print the edge protectors with personalized messages like FRAGILE, DO NOT STACK, BRAND LOGOS or any standard messages.

Personalized pre-printed edge protectors will help to prevent lost of shipments, identity / secure your shipments and further enhance your company / brand logos.

# ENVIRONMENT

Environment conservation is highly regarded at CFL. RoHS-Compliant, 100% recyclable materials are used, repulpable, shreddable and compactable using existing waste streams. Our total commitment to environmental management system is evident and we have been awarded with Industrial Design for A Module Pallet (MY09-00640-0101), we also filing Patent Application for A Pallet (PI 2010000227), A Laminated Article (PI 201000026) and pallet with reinforced runner (PI2014703084).

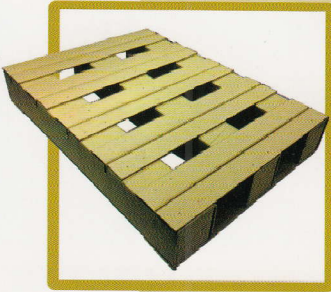

## PAPER PALLET

Pallet made by paper to replace wooden pallet, more eco friendly and made to order



## TOP COVER PAPER PALLET

Pallet made by paper to replace wooden pallet, more eco friendly and made to order



## RUNNER BOX

Due to certain Environment Policy request. It is made to replace wooden runner and it is able to withstand up 1 tone weight.



## FLAT BOARD

widely use as separator space to prevent damages to product when stacking apply.

# PAPER PALLET

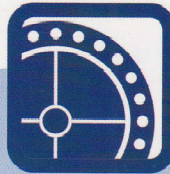

PROTECTION  
PRODUCT

# EDGE PROTECTION



## EDGE PROTECTOR

cover with kraft paper and widely use to protect the four corner of the pallet

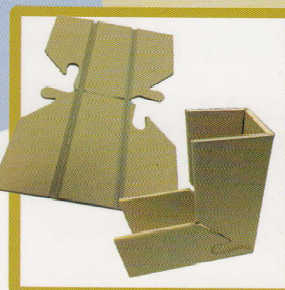

## Foldable L BOARD

special design for corner protection for frame, door and other squares item



## WHITE EDGE PROTECTOR

capable to perform certain water resistant and function as Edge protector.

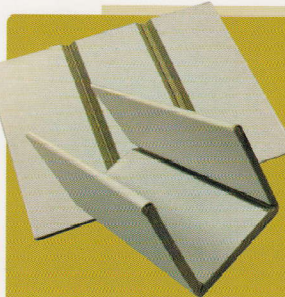

## FOLDABLE U BOARD

Design to overcome Form U board, save spacing and highly reduce transportation cost.



## DIE - CUT EDGE PROTECTOR

### 2 IN 1 USAGE

- 1) To act product display boards by typing up your product and hang it on the wall / display rack.
- 2) To protect your product corner from damage.

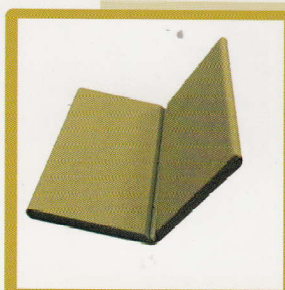

## Foldable Edge Protector

Design and tailor made to overcome big angle corner protection.

## BENEFITS OF USE

Our edge protectors are widely used as an economical alternative for protecting and securing loads. It prevents damages to the edges of palletized loads and reduces complaints / claims from customers. It is an ideal option for stretch wrapping system.

### EDGE PROTECTION

Edge protectors have proven their values in strengthening and stabilizing loads without affecting the edges / sides of shipment.

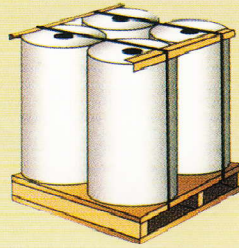

### INTERNAL PROTECTION

Reinforcing corrugated paper boxes to ensure safety in transit and enhancing additional stacking strength.

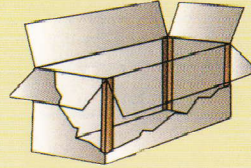

### STABILIZES / IMPROVES STACKING STRENGTH

Combined with strapping, edge protectors help to eliminate skids and damages, while providing extra strength when double stacking.

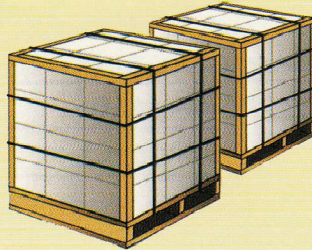

### FLEXIBLE PROTECTION

Specifically designed for product protection of different shapes. Provides safety and prevents damages during storage or transit.

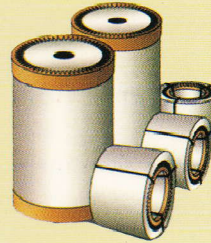

## TEST CONDITION :

- Temp 30 C RH 75%
- Test Speed of 20mm per minute
- Break Rate 85%
- The Edge Compression Test was conducted by using a specimen height of 100mm
- The Flexural Stiffness Test was conducted by using a beam length of 140mm

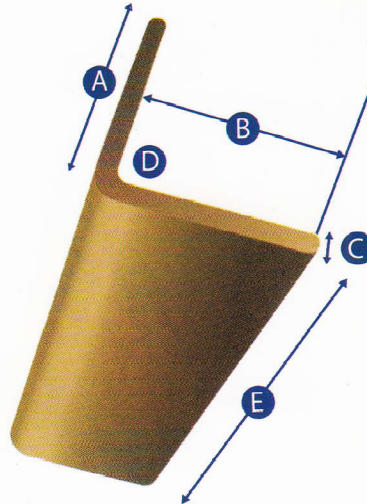

## PRODUCT OUTER DIMENSION

A	B
35mm ± 2mm	35mm ± 2mm
40mm ± 2mm	40mm ± 2mm
50mm ± 2mm	50mm ± 2mm
60mm ± 2mm	60mm ± 2mm
90mm ± 2mm	90mm ± 2mm
C	
1.2 ~ 7mm +/- 0.5mm	
D	E
85° ~ 90°	XXXXmm ± 2mm

## RAW MATERIAL :

- Core Board Paper
- Cold-Based Water Soluble Glue

## EDGE PROTECTOR PRODUCT PERFORMANCES

Dimension	Thickness	Edge Compression Test	Flexural Stiffness Test
35mm x 35mm	3mm	120kg ± 10%	50kg ± 10%
	4mm	200kg ± 10%	70kg ± 10%
	5mm	230kg ± 10%	90kg ± 10%
50mm x 50mm	2mm	70kg ± 10%	40kg ± 10%
	3mm	170kg ± 10%	80kg ± 10%
	4mm	260kg ± 10%	100kg ± 10%
	5mm	310kg ± 10%	125kg ± 10%
60mm x 60mm	3mm	220kg ± 10%	80kg ± 10%
	4mm	280kg ± 10%	100kg ± 10%
	5mm	350kg ± 10%	125kg ± 10%