



THE WORLD OF SCHÜTZ AUSTRALIA



Sustainable Packaging – our commitment since decades.

Established in the 1970s, today SCHÜTZ Australia is the leading supplier for sustainable packaging systems on the continent. The company manufactures and distributes SCHÜTZ ECOBULK/RECOBULK – the world's most successful IBC system that combines the benefits of one-way packaging with those of a closed-loop system.

Together with our range of tight and open-head plastic drums, we provide our customers with highly efficient, reliable and eco-friendly packaging for applications in the fields of agricultural chemicals, industrial chemicals, lubricants, food, beverages, pharmaceuticals and many dangerous goods. Offering full system solutions, SCHÜTZ Australia takes care of the collection and ecological reconditioning of the emptied packaging within the scheme of the worldwide SCHÜTZ TICKET SERVICE.

With our nationwide production service network, complemented by our offices throughout Australia and Southeast Asia, we are present in the main industrial areas of the region – ready to offer reliable supply and speedy reaction times to our customers.

Being the first and only Australian producer of IBCs featuring inner bottles with up to six layers, SCHÜTZ Australia stands for state-of-the-art production technology and continuously invests into new facilities, machinery and equipment.





**HEAD OFFICE
MELBOURNE**

17 Burr Court,
Laverton North VIC 3026

Central-Phone: 03 9360 9291
Mail: salesau@schuetz.net



BRISBANE

23 Arthur Dixon Crt,
Yatala QLD 4207



PERTH

146 Cockburn Rd,
North Coogee WA 6163

SCHÜTZ ECOBULK – the IBC system for every requirement.

Efficient space utilisation and low weight combined with maximum safety and user friendliness – the benefits of the versatile SCHÜTZ IBC system make the ECOBULK/RECOBULK the perfect logistics tool.

BENEFIT FROM:

- Speedy filling and discharge processes using conventional equipment
- Ideal for use with automatic filling and transport systems
- Large label plates for safety and fast, easy labelling
- Simple discharge processes and very good evacuation of residues
- Worldwide collection and reconditioning of packaging by SCHÜTZ
- Perfect stackability and ideal suitability for high-bay storage systems
- Static load up to 4 units high and dynamic load up to 2 units high
- No cost-intensive administration, tracking or return of empty packaging

1,000 litres capacity





EXPLOSION PROTECTION

Packaging types for use in ex-zones.

ECOBULK MX-EX ANTISTATIC

- Suitability for filling products with a low flash point of $\leq 60^{\circ} \text{C}$
- Suitability for use in areas with explosive gaseous or vaporous atmospheres
- No electrostatic charge during filling, emptying and transportation



EVOH BARRIER

For particularly sensitive filling goods.

ECOBULK MX-EV

- 6-layer inner bottle with integrated EVOH barrier
- Reliable prevention of filling good permeation
- Prevention of gases, such as oxygen, carbon dioxide and nitrogen, entering or escaping
- No permeation of flavours or odours
- Barrier for oils and grease
- Barrier preventing the diffusion of solvents



SCHÜTZ FOODCERT

The new food safety standard.

ECOBULK MX FC

- System certification according to FSSC 22000 (Food Safety System Certification, based on ISO 22000 in combination with ISO/TS 22002-4)
- Contains FDA compliance of materials
- Certification recognised by GFSI (Global Food Safety Initiative)
- Halal and kosher certification



UV PROTECTION

3 x enhanced barrier against visible light.

ECOBULK MX WITH WHITE INNER BOTTLE

- Efficient UV radiation barrier
- Extended shelf life of packaged products (e.g. resins and additives)



EVOH + EX PROTECTION

No chance of permeation – even in ex-zones.

ECOBULK MX-EX-EV ANTISTATIC

- 6-layer inner bottle with integrated EVOH barrier and antistatic outer layer
- Combining the features of MX-EX and MX-EV



NON-DANGEROUS GOODS

For non-classified filling products.

ECOBULK MX

- Without UN certification
- Most economical solution for non-hazardous filling goods

SCHÜTZ SAFEGUARD for IBC outlet valves.

Comfortable opening and closing mechanism for repeated discharge. The user-friendly operation simplifies the fulfilment of regulations for the transportation of filled and emptied containers.

INSTRUCTIONS:

1. Push handle slightly and lift yellow clip completely
2. Check if yellow clip is lifted completely
3. Pull handle to open valve

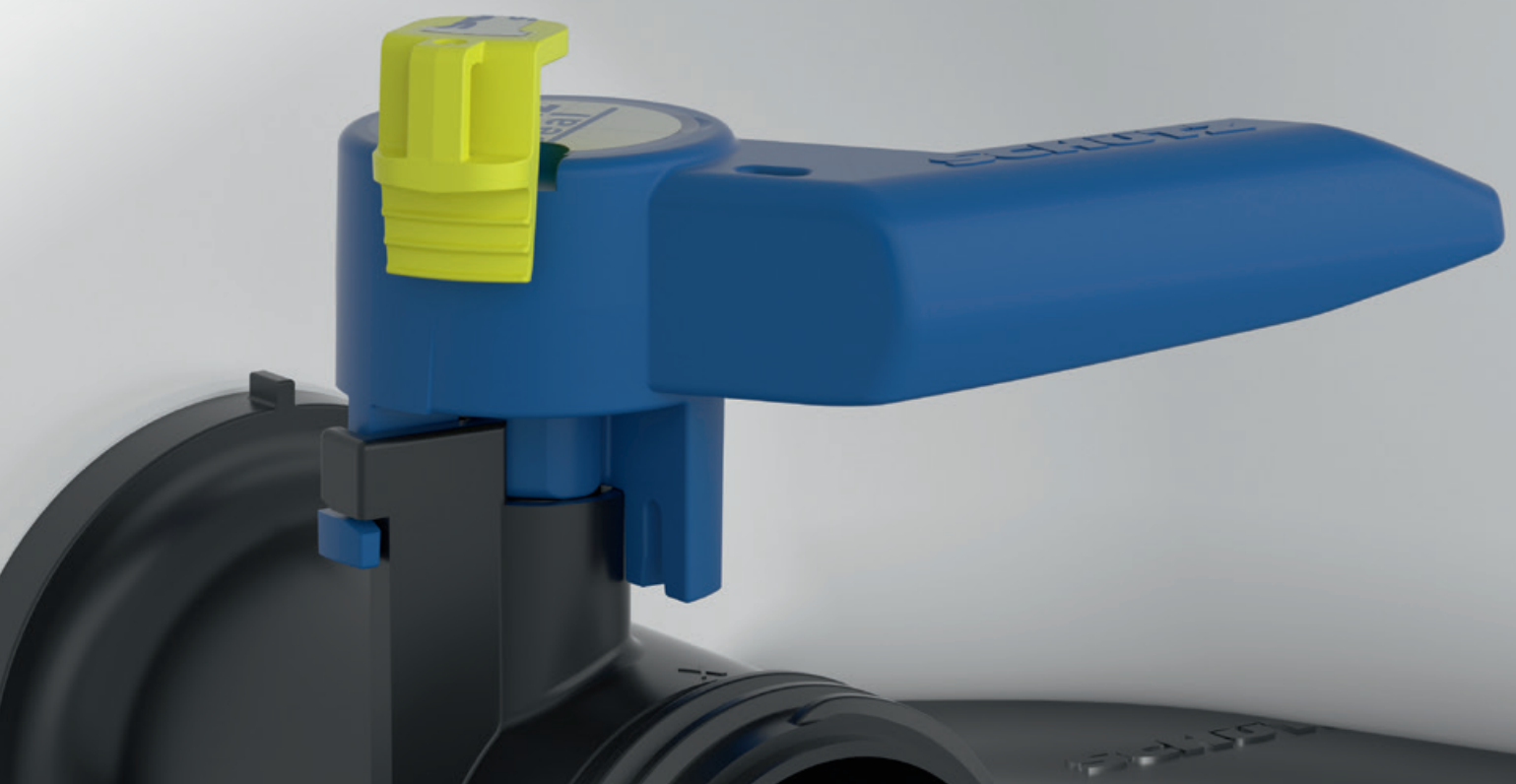
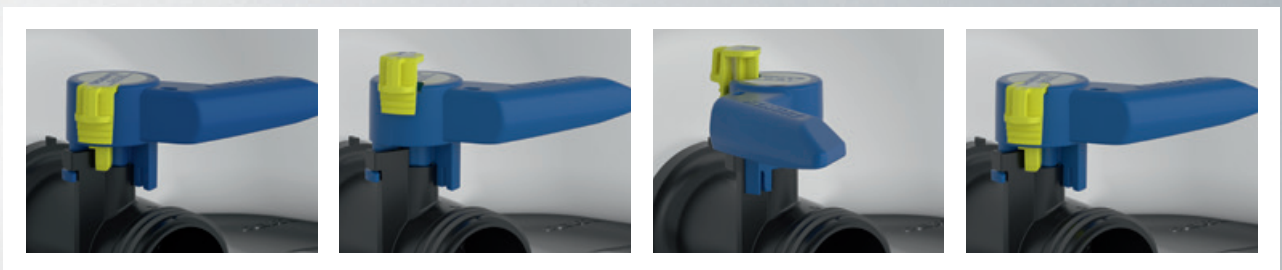

SCHÜTZ IMPELLER – mix and stir with cleanliness and efficiency.

Discover the new complete solution for maximum cleanliness, safety and economy for all products that need to be stirred or homogenized in the supply chain. The single-use system consists of an ECOBULK with an integrated SCHÜTZ IMPELLER.

- The IBC remains closed and sealed throughout the supply chain, even during stirring
- Significantly reduced costs and effort compared to stainless steel agitators
- Contamination risks are completely eliminated
- No need to clean – simply return empty ECOBULK and Impeller via SCHÜTZ TICKET SERVICE



Plastic drums by SCHÜTZ – built to meet highest standards.

As a leading supplier of packaging systems, we consistently adapt our product range to meet the needs of our customers. SCHÜTZ Australia supplies both global standard drums as well as customised product solutions for regional requirements and specific applications.



SCHÜTZ F1 tight-head drums

The SCHÜTZ F1 tight-head drum is a true global player. It is produced at all SCHÜTZ sites on all continents to the same design and specifications. Its outstanding characteristics are high dimensional accuracy and exceptional overall performance.

- Suitable for automatic filling lines thanks to precise bung calibration and optimised bottom plate
- Optimised dimensions for transport in ISO containers
- Excellent handling characteristics
- Can be easily moved with all standard drum grippers
- Best residual draining to less than 100 ml through both bung holes
- Upper ring design guarantees best stackability and optimum protection of bungs and labels



SCHÜTZ AUTOMATIC LOCK

The innovative seal cap system with the AUTOMATIC LOCK originality seal protects your filling products from tampering or contamination. It is impossible to open the plug without destroying the seal cap. Suitable for manual and automatic fitting.

- Suitable for both food grade and dangerous goods applications
- System consists of a red sealing cap and a corresponding plug with special latching hooks



SCHÜTZ OC open-head drum

These high-performance drums provide a solution for a myriad of filling goods, such as pastes, pellets, granular material and powders.

- Technically the best solution for PE drums using the SCHÜTZ Security Layer Technology
- Excellent material compatibility featuring natural HDPE on the inside of the drums
- No colour pigments on the inside, therefore the highest purity and best filling product protection
- With optional FDA certification suitable for the transport of food products and other similar filling products



The new SCHÜTZ SQ2 tight-head drum – packaging efficiency squared.

Space-saving design, suitable for many different applications and optimum reusability – our new SQ2 tight-head drum offers the highest **efficiency, safety and resource** conservation for daily use.

Thanks to the square cross-section, nine SQ2 tight-head drums will fit on a pallet (1,165 x 1,165 mm). This corresponds to up to 900 litres of filling product and approx. **65 % more transport volume in comparison to conventional drums in this volume!**

The resulting **economic and ecological advantages** combined with first-class product quality make the SQ2 tight-head drum a highly attractive packaging solution for a wide range of industries and filling products.

For agrochemical applications, for use with other hazardous filling products or for foods and technically demanding liquids – the closed discharge system and the optional EVOH barrier offer additional safety.





The stable **top ring** with two grip holes facilitates easy manual handling and secure nesting for double stacking.

The **SCHÜTZ "dry-break" discharge valve** protects against contact with the drum contents and product contamination.

The **drum body** is made of high-quality HDPE and has excellent resistance to chemicals and stress cracking.

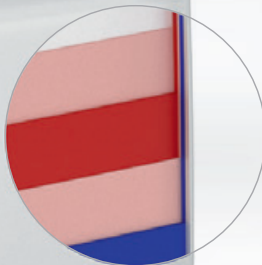

Optional: An **integrated EVOH barrier** prevents the permeation of gases, solvents and flavouring agents.

The drum has a large, flat space for **labels and markings**.



The shock-absorbing **SCHÜTZ DIPTUBE** sits at the lowest point of the drum geometry and guarantees optimum residual emptying.



The entire drum system is optimized for cost-saving and resource-conserving use in a **closed-loop system**.

Locally designed G2 drum.

Fitted with a SCHÜTZ designed dry break valve and diptube to prevent exposure to the filling good, these drums are available as new for particularly sensitive applications or through a more economical washed system.

- A reusable drum specifically designed for the agricultural chemical industry
- Suitable for dangerous goods applications
 - UV additives to protect the drum from the harsh Australian sun
 - Rated to hold liquids with a maximum specific gravity of 1.6 or up to 176 kg gross weight
 - Excellent environmental stress crack resistance required for herbicides that contain aggressive surfactants

- Typically filled to 110 liters with approval to hold and transport hazardous chemicals including:
 - Class 6 Toxic liquids
 - Class 8 Corrosive liquids
 - Class 9 Environmentally hazardous liquids



Thanks to further local investment in 2018, the G2 drum is now also available in the EVOH barrier technology, delivering to our customers consistent and reliable prevention of filling good permeation or diffusion.



SCHÜTZ DIPTUBE for IBCs and drums.

Our dry-break valve is the result of years of R&D in order to create a valve that is durable, cost effective and directly compatible to all dry break systems currently used by the Agricultural Chemical Industry.

The patented SCHÜTZ dry-break valve with diptube mechanism ensures maximum extraction of liquids from drums and IBCs. It also acts as a shock absorber between the base of the packaging and valve assembly – preventing potential valve failures when handling containers.

Diptube:

- Cross linked polyethylene
- Stainless steel fastener ring secures diptube to dry-break valve
- 25 mm inner diameter diptube

Dry-break valve:

- Glass filled nylon
- Viton seal
- Stainless steel compression spring

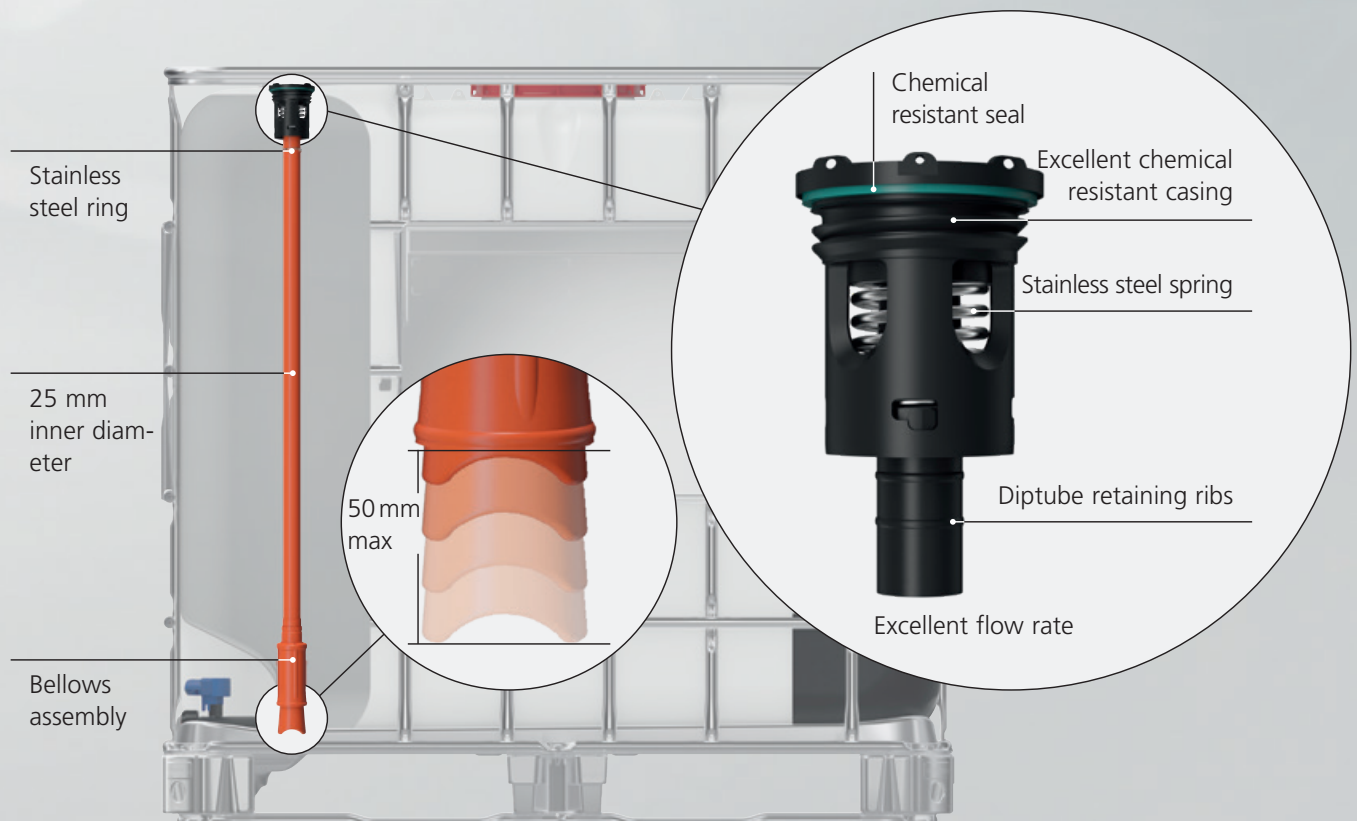

Collection and reconditioning of IBCs and drums.

You can request your collections online with the web form, our new mobile app, by e-mail or personally by phone – Contact us ticket.australia@schuetz.net or visit our websites www.schuetz.net/ticket and www.returnyourdrums.com.au for more information.

Order a
collection

1

As RECOBULK, the SCHÜTZ IBCs provide complete product safety again. The UN approval for the container is extended for a further five years. The drums are ready for the next application as well.

5

New cycle



4

Washing & Reusing

The IBC steel components are thoroughly cleaned and repaired if necessary. The drums are washed for reuse.

Replacing
components

3

For the IBC: all components that came into contact with the filling product – e.g. the inner bottle, screw caps and valves are replaced with new original components. For the washed drums: replacement of all dip-tubes and valves where necessary.



SCHÜTZ

ECOBULK / REGOBULK

Benefit from our intelligent recycling system.



Your empty packaging gets collected

2

Collection will take place within a few days. We will get in touch if there are any questions or to arrange a collection time.



Each reconditioned SCHÜTZ IBC produces roughly **100 KG** less in carbon emissions than a new IBC.

By returning your empty IBCs and drums through the SCHÜTZ TICKET SERVICE you are making an active contribution to lower costs, high quality standards, safe recycling material flows and improving the eco balance of packaging in your supply chain.

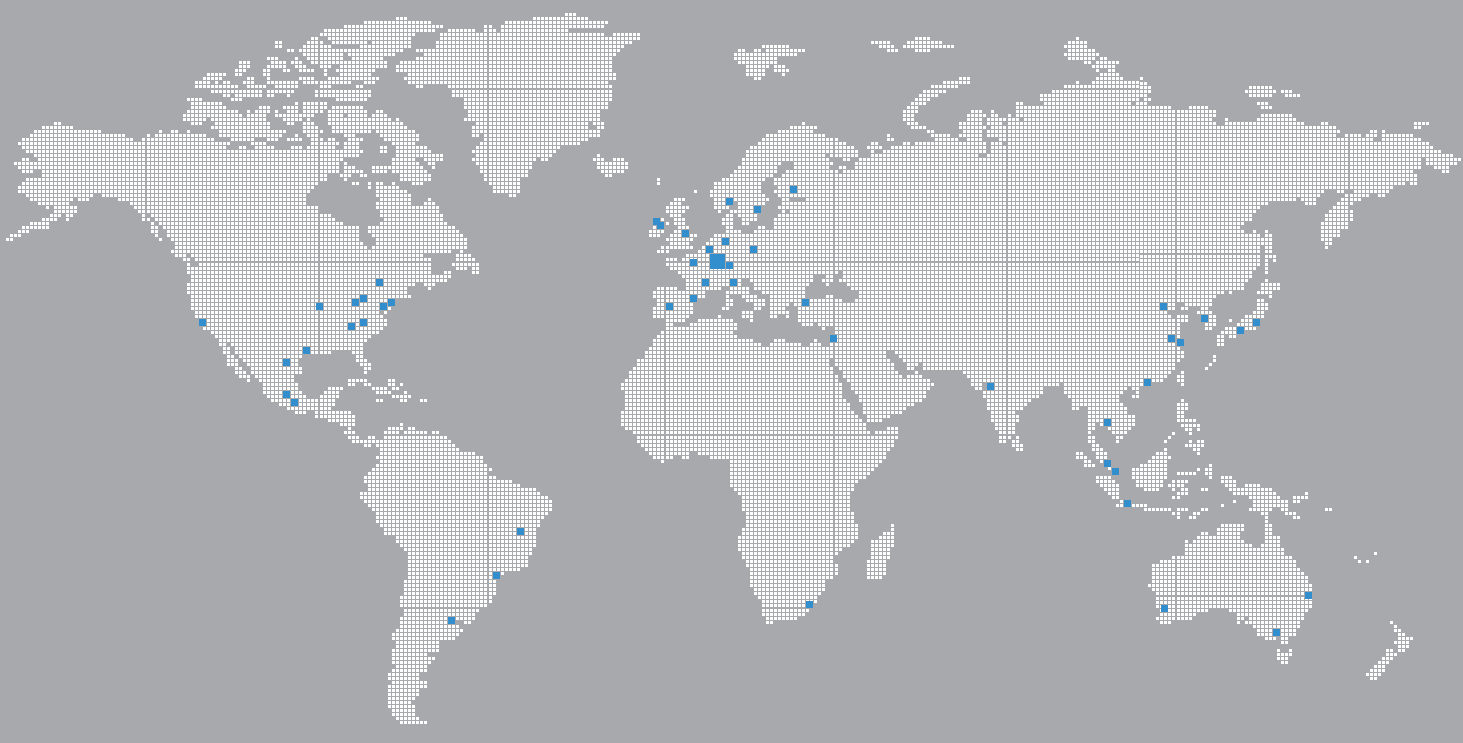

With our worldwide production and service network,
we are also close to you.

All SCHÜTZ locations can be found at:
www.schuetz.net/global



SCHÜTZ Australia Pty Ltd. Head Office · 17 Burr Court
AU-Laverton North VIC 3026 · Phone +61 3 9360 9291
salesau@schuetz.net · www.schuetz.net

