



TRAY-SEALER TDF

# WHO WE ARE

The company, based in northern Italy, commenced manufacturing packaging machines in

**1973 ...**

almost **50 years** of packaging experience!

This small company expanded in a few years, to become a true leader in the field. Since then, Coligroup has provided more **innovative** and **reliable** solutions year after year in the packaging industry.

[www.colimatic.com](http://www.colimatic.com)



# HEADQUARTER (8300 mq2 in 5 plants)

- ①
- R&D
  - Accounting and controlling
  - Marketing
  - Operator Training
  - HR
  - Assistance and support

- ②
- Production
  - Tests (FAT)
  - Industrial Plant

- ③
- Mechanical components manufacturing

- ④
- Logistic

- ⑤
- Warehouse





46

YEARS OF EXPERIENCE

3700+

LINES INSTALLED

62

COUNTRIES WE EXPORT TO



70% EXPORT SHARE

Confidential



# MACHINERY RANGE



TDF 1650 - 1900

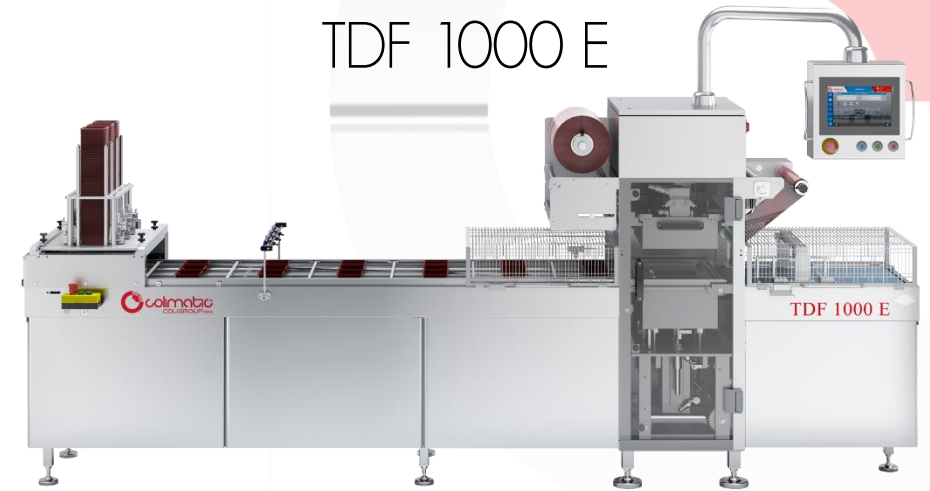

TDF 1000 E

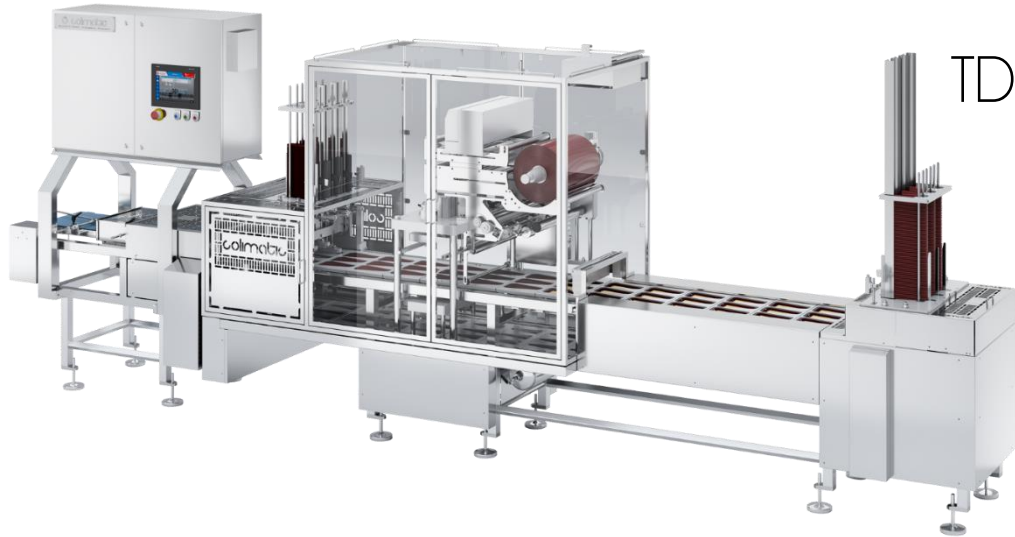

TDF 1500



TDF 500 SEMI-AUTOMATIC

# TRAY - SEALER

Different packaging applications



Only sealing - MAP



SKIN - SKIN with protruding



# AUTOMATIC TRAY - SEALER 1650 - 1650 DOUBLE

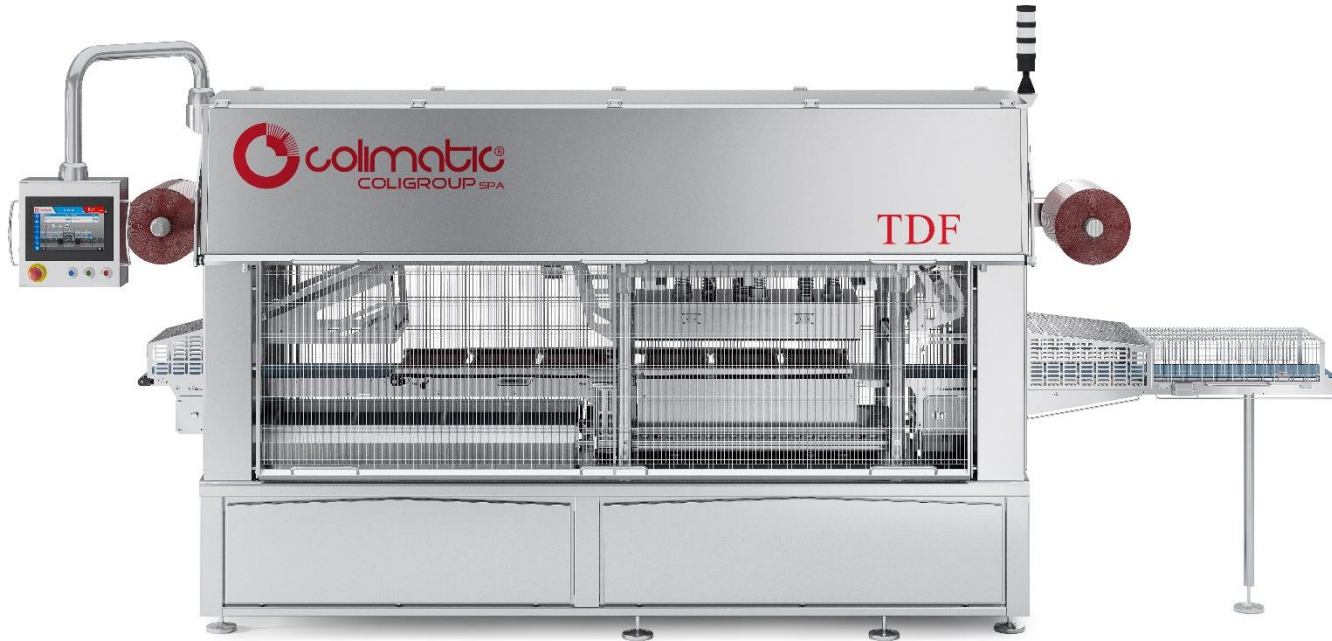

Revolutionary fully automatic Tray sealer **TDF series**: for the packaging of plastic, cardboard & aluminium preformed trays, with on-reel plastic film lids, carton lids & reclosing-cap application option.

Machine frame completely realized in stainless steel: metal sheets obtained by laser cutting, electrically welded holding elements.



# AUTOMATIC TRAY - SEALER 1650 - 1650 DOUBLE

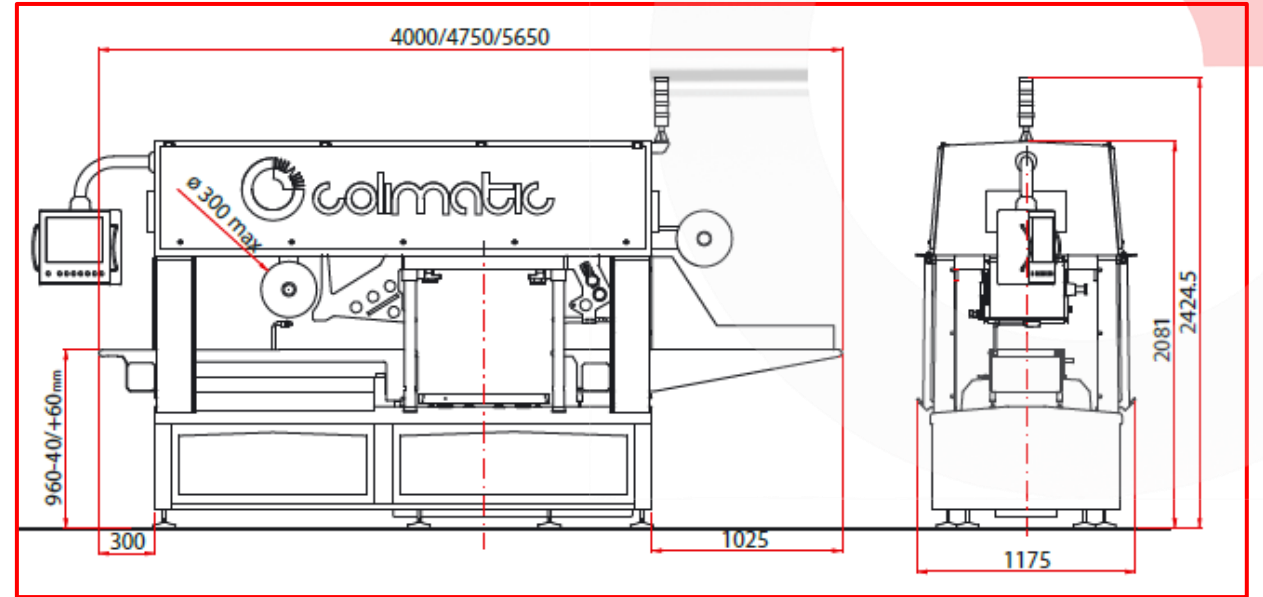

## MAXIMUM TRAY DIMENSIONS

TDF 1650	<p>206</p> <p>320</p>	<p>151</p> <p>320</p>	<p>118</p> <p>320</p>	<p>95</p> <p>320</p>	<p>80</p> <p>320</p>	<p>68</p> <p>320</p>
TDF 1650-D	<p>206</p> <p>150</p>	<p>151</p> <p>150</p>	<p>118</p> <p>150</p>	<p>95</p> <p>148</p>	<p>80</p> <p>80</p> <p>80</p>	<p>68</p> <p>68</p> <p>68</p>

# AUTOMATIC TRAY - SEALER 1650 - 1650 DOUBLE

## TRAY PUSHERS and COVEYOR SYSTEM



- Servomotor Independently controlled pushers
- Cam system for perfect tray Position control
- This belt continuous motion can be adjusted from the HMI
- Fast belts removal without tools, for easy cleaning



- N.3 Servomotor controlled conveyor belts, for trays perfect positioning.
- Stainless steel structure, transport belt realized in polyurethane.

# AUTOMATIC TRAY - SEALER 1650 - 1650 DOUBLE

## SEALING CHAMBER



- HMI controlled: Sealing pressure, sealing time and mould lifting speed
- Sealing pressure strength: Up to 8 tonnes !
- The lifting of the sealing mould is made directly by Servomotor
- Speed: Up to 15 cycles/min
- MAP & additional formats optional



# AUTOMATIC TRAY - SEALER 1650 - 1650 DOUBLE

## MOULD & REEL HOLDER

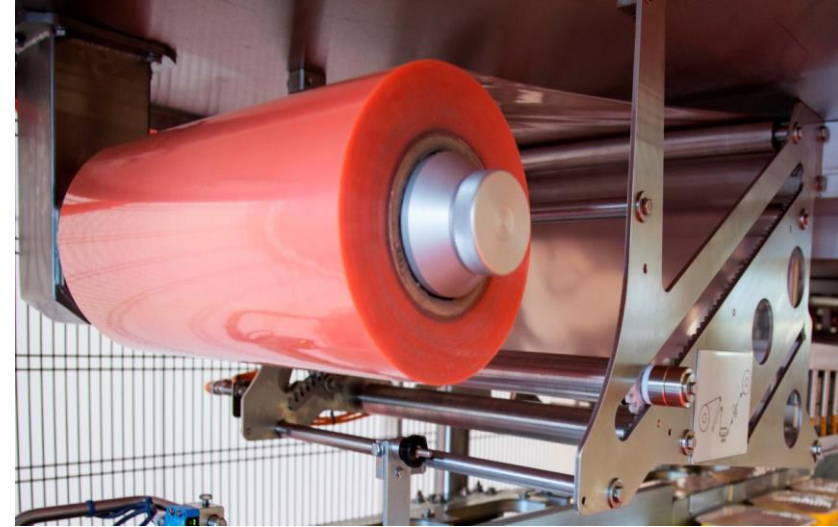

- Rock solid moulds and sealing plates
- Motor driven Reel holder, for the lid film
- Pneumatic expansion
- Servomotor controlled film transport
- The motor is positioned inside the electrical cabinet

# AUTOMATIC TRAY - SEALER 1900 - 1900 D





# AUTOMATIC TRAY - SEALER 1900 - 1900 D

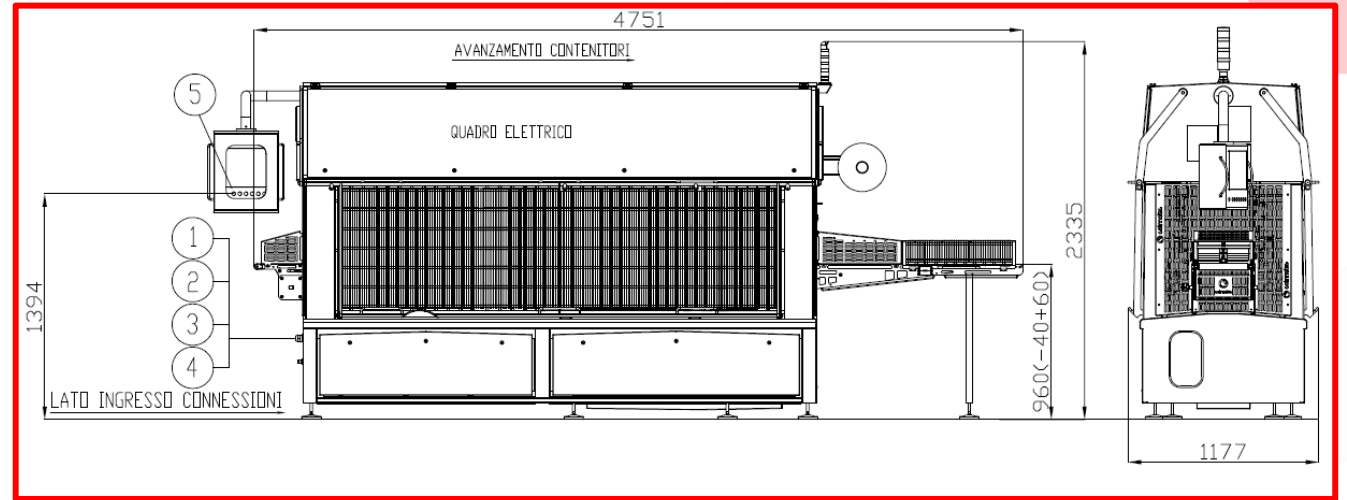

## MAXIMUM TRAY DIMENSIONS

TDF 1900	<p>290</p> <p>320</p>	<p>214</p> <p>320</p>	<p>168</p> <p>320</p>	<p>137.7</p> <p>320</p>	<p>115</p> <p>320</p>	<p>99</p> <p>320</p>
TDF 1900-D	<p>290</p> <p>150</p>	<p>214</p> <p>150</p>	<p>168</p> <p>150</p>	<p>137.7</p> <p>148</p>	<p>115</p> <p>115</p>	<p>99</p> <p>99</p>



# Automatic TRAY - SEALER TDF1000 E

## TDF1000 E

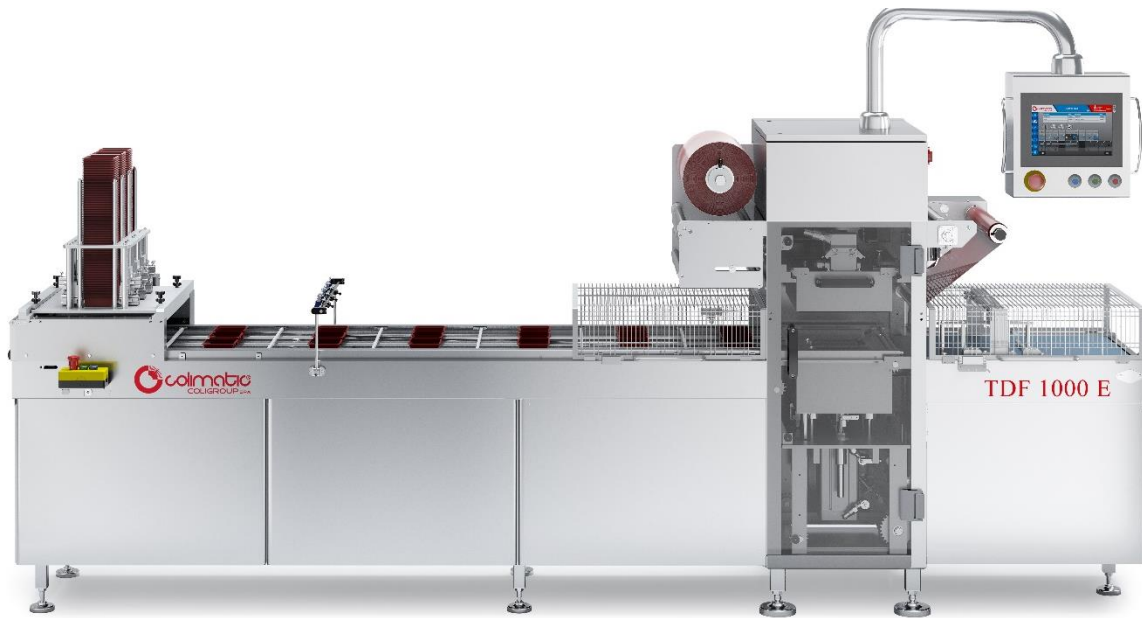

- Colimatic TDF 1000 E is an automated, **FLEXIBLE** packaging machine that fully meets the market's packaging needs
- It satisfies the most stringent **QUALITY, SPEED** and **SAFETY** standards that are typically met by larger, more expensive machines
- It incorporates an array of state-of-art technical details in a highly **ERGONOMICALLY-FRIENDLY, RELIABLE, USER-FRIENDLY** machine.
- It is fully **CUSTOMIZABLE** and can be easily **CONFIGURED** with infeed and outfeed conveyors, tray aligner, checkweighers, vibration and dosing units, markers and lid placers to meet even the most demanding and complex packaging needs
- Its small footprint, competitive price and low running costs make it the ultimate packaging solution on the market for optimized performance and efficiency.

# Automatic TRAY - SEALER TDF10000 E

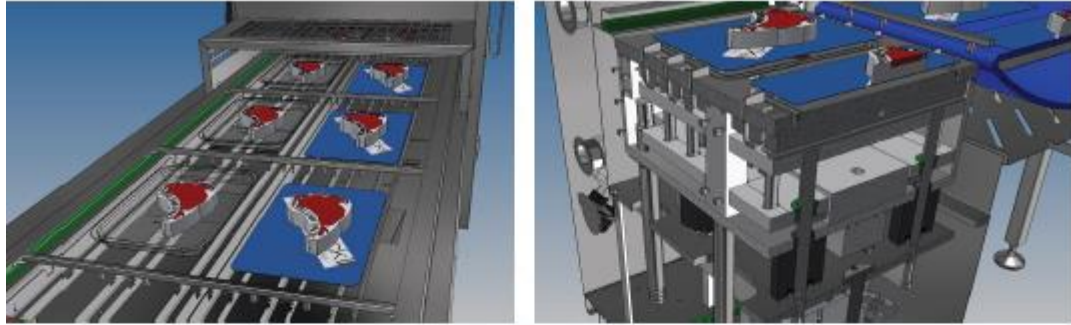

- Tray size: maximum of mm 400x275, with a maximum height of 110mm
- Models is available for 205 mm buckets.
- This machine is able to seal trays in PE, PP, PET, PS, CPET, aluminum, etc. (CPET and aluminum are suitable for oven use).
- We are able to perform protrusion packaging up to 35mm
- The machine can be configured with 1, 2, 3 or 4 rows as we can make the tools with 1, 2, 3 or 4 impressions, depending on tray size

# Automatic TRAY - SEALER TDF1000 E

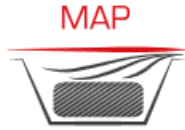

MACHINE CYCLES up to 8/10 cycles/min

MAX TRAY DIMENSION

MAXIMUM TRAY DIMENSIONS

TDF 1000		



# Semi-automatic TRAY-SEALER mod. TDF 500

## TDF 500

TDF 500 is the perfect solution for packing of various products with vacuum and modified atmosphere with a minimal investment. Semi-automatic tray-sealer for small production outputs



## TDF 500 SA

TDF 500 SA with its rotating turntable considerably cuts cycle times and optimizes output.

It allows for the loading and unloading of trays while the machine is completing the cycle in the second vacuum chamber.



## MAXIMUM TRAY DIMENSIONS

TDF 500				
---------	--	--	--	--

# Semi-automatic TRAY-SEALER mod. TDF 500



- State-of-the-art electric board with up to 10 packaging programs, language selection, integrated temperature control, menu-driven M.A.P. parameters, gradual vacuum and film sealing only.
- Tool-less vacuum chamber removal ensures high standards of hygiene and cleanliness.
- Tool-less die changing in less than 2 minutes

TOP SEAL



MAP

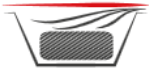

SKIN TECHNOLOGY



SKIN PROTRUDING



EASY PEEL



GAS FLUSH



# SPECIAL AUTOMATIC TRAY - SEALING LINE mod. TDF1500

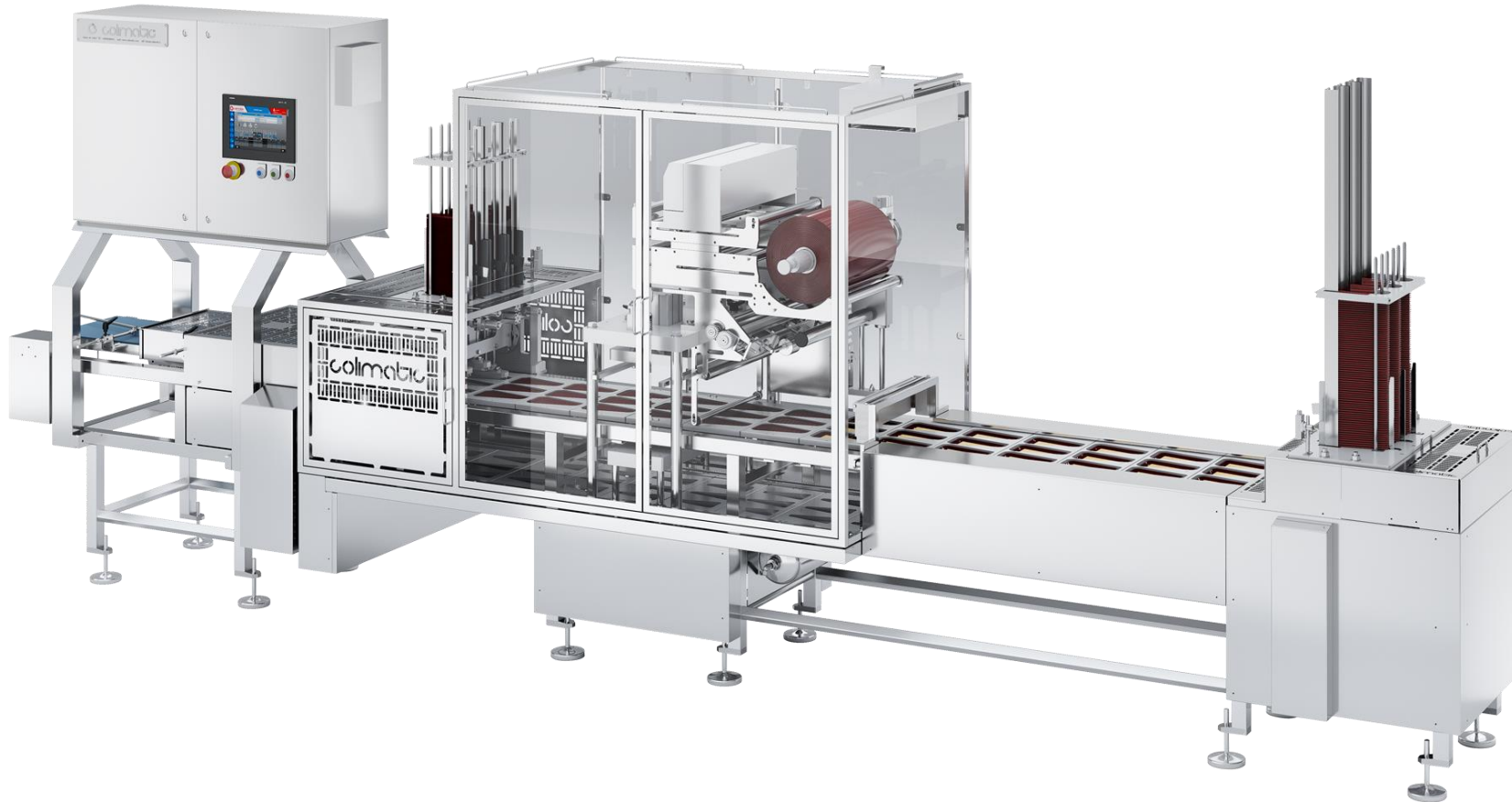

The fully automatic cup thermosealing line mod. TDF 1500 is a unique solution that combines automatic tray loading, product feeding, data printing, and aroma-saving lid applicator with a compact design.

On top of that, the multi-cavity chain advancing movement allows this machine to reach higher production capacity



# SPECIAL AUTOMATIC TRAY - SEALING LINE mod. TDF1500

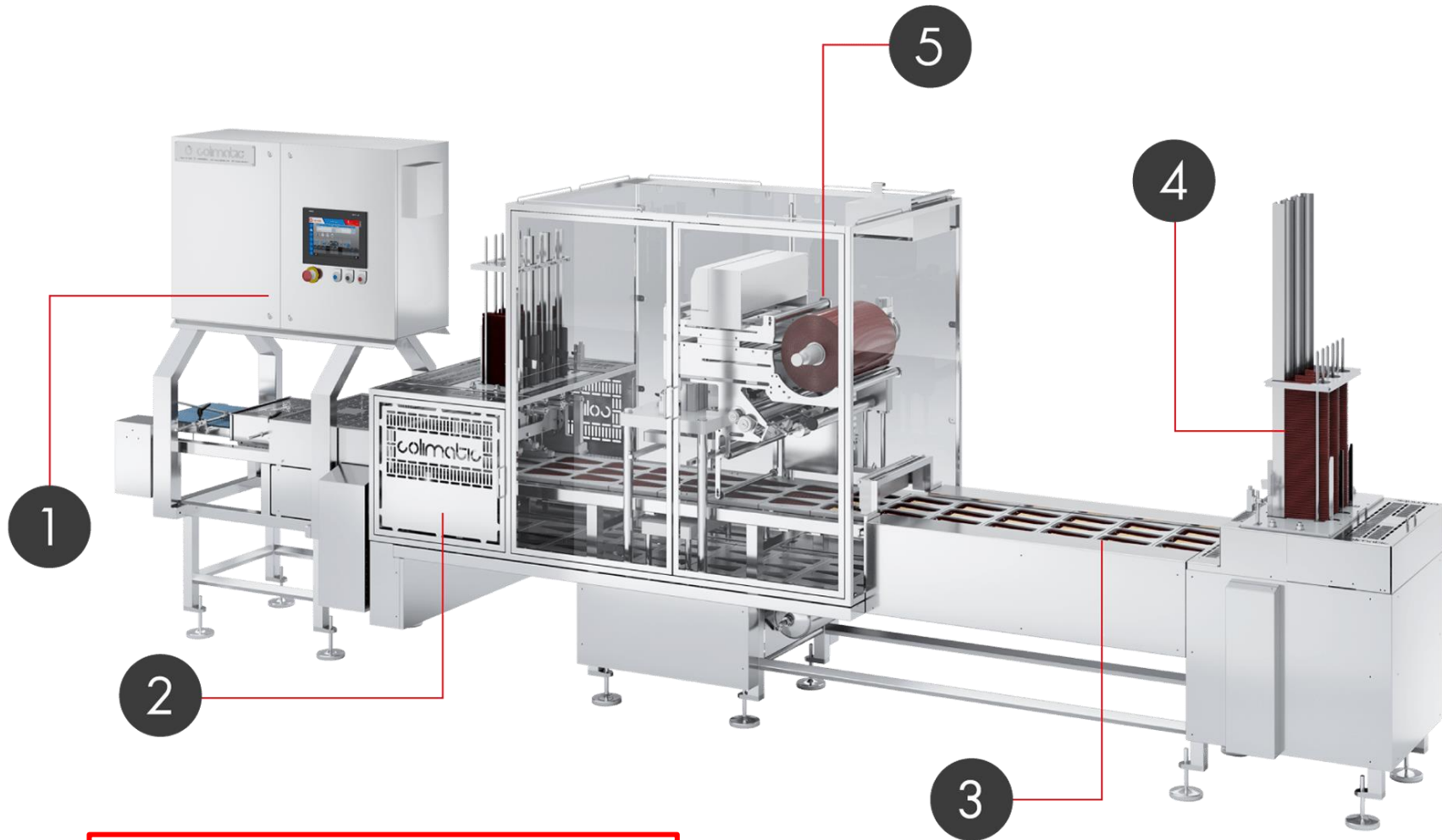

1. Aligning system
2. Automatic lid applicator
3. Special pocket chain application
4. Automatic trays denester
5. Printing device for variable data

Up to 22 cycles/minute!



# Example of TRAY-SEALER Application











# Example of TRAY - SEALER Application







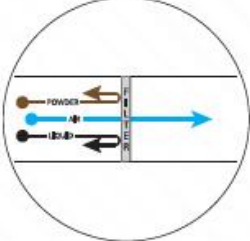

# OPTIONAL AVAILABLE

<p>Trolley for changing tool</p>	
<p>Vacuum pump</p>	
<p>Motorized infeed conveyor 1/2/3 Standard</p>	
<p>Infeed inline divider</p>	

<p>Exit aligner 2/3/4</p>	
<p>Liquid or powder filter for vacuum pump</p>	
<p>Gas tank</p>	
<p>Denester quick change format</p>	

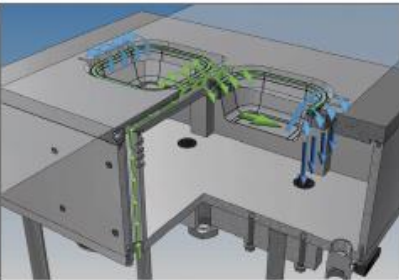

# OPTIONAL AVAILABLE

Doser predisposition	
Vibrating units	
Thermal transfer	
Exit motorized 1/1.13 meter Extra requested also 90 degree	

Smart Gas	
Dedicated template to adjust the guides for tool change	
Pre-heating	
Film Micro perforation	

# OPTIONAL AVAILABLE

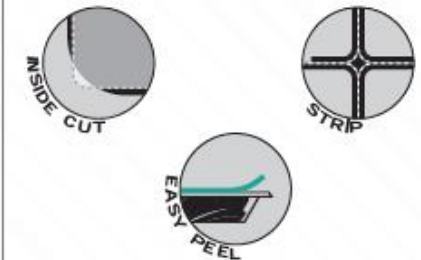
<p>Film reel Expanding shaft Film waste expanding shaft</p>	
<p>Weight check</p>	
<p>Lid applier</p>	
<p>Remote assistance modem</p>	

<p>Tray detection Photocell</p>	
<p>Easy peel - Rounded sealing plate - Multi Compartment tray - Convex sealing - Small edge sealing - Inside cut</p>	
<p>Chamber filling plates</p>	
<p>Photocell for printed film</p>	



# OUR CUSTOMERS

# OUR CUSTOMERS

				
 <p>SALUMIERI PIEMONTESE DAL 1946</p>				
				

# AFTER SALES SERVICE



- Local support 24/24
- Remote tele-assistance
- Operator Training
- Preventative maintenance
- Spare parts packages



«Our customers' success is our mission!»

SMALL  
ENOUGH TO LISTEN  
BIG ENOUGH  
TO SERVE!

Thank you for your attention!



Coligroup SPA

Via del Lavoro A. 9

25032 Chiari (Brescia) Italy

Phone: +39 030 7000761/2/3

Fax: +39 030 713370

E-mail: [info@colimatic.com](mailto:info@colimatic.com)