



BAKERY &
SANDWICH



WHO WE ARE

The company, based in northern Italy, commenced manufacturing packaging machines in

1973

almost **50 years of packaging experience!**

This small company expanded in a few years, to become a true leader in the field, **now the FIRST thermoforming producer in Italy!**

Since then, Coligroup has provided more innovative and reliable solutions year after year in the packaging industry.



Premises: 15,000m²

7 buildings

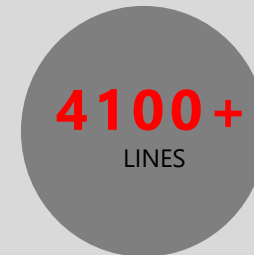



WHAT WE DO?

INTEGRATED PACKAGING SOLUTIONS

with automatic robotic loading system, printers, labelers and control vision systems.

PACKAGING TECHNOLOGIES

Blister, MAP, Vacuum, SKIN and Shrink

AFTER-SALES SUPPORT and production management

EXPERTS CONSULTANCY

packaging trials and packaging material tests.

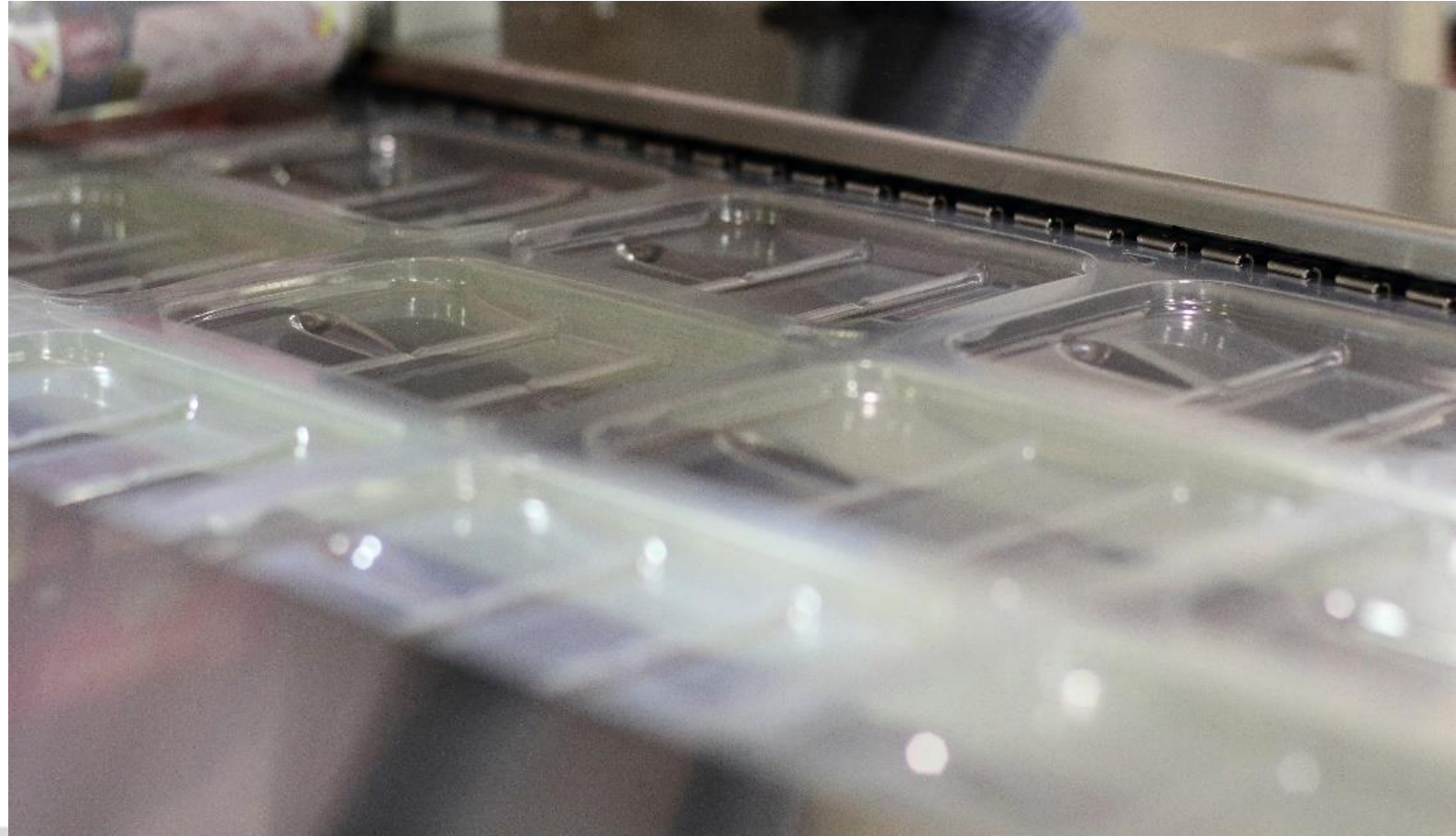

TOP SEAL



MAP

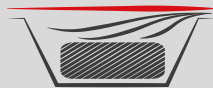

GAS FLUSH



SKIN

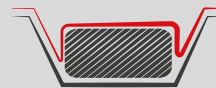

SKIN PROTRUDIN G



FLAT SKIN PROTRUDIN G

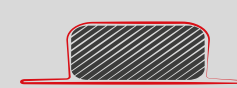

FLAT SKIN SUPER PROTRUDING



SOME OF OUR REFERENCES



Mondelēz
International





MACHINERY RANGE

THERA 100



THERMOFORMING MACHINES

THERA 250



THERA 450



THERA 500



THERA 650



TRAYSEALING MACHINES





LABELING UNITS

PRINTING SOLUTIONS

CARTONING MACHINE

DOSING SYSTEM

REJECTION SYSTEM

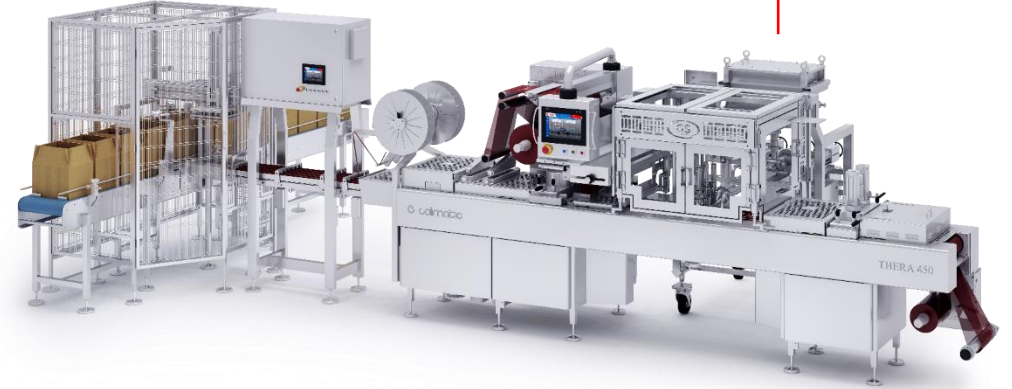

AUTOMATIC PICK & PLACE SYSTEM

AUTOMATIC SLICER



**INTEGRATED
PACKAGING SOLUTIONS**

LISA[®] Line Integrated System Assistant



Innovative DPM software for the management of lines integrated in the production flow. Its functions allow to maintain the efficiency of the lines at the maximum level.

WSM Warehouse Spare parts Management)

DPM Data Process Management

Machine operating status
continuous monitoring

Spare parts warehouse management

PRD Predictive Diagnosis

Timely **preventive** maintenance

TLS Teleservice

Remote assistance

ASC Automatic Set up Control

Work Order acquisition and related process parameters setup

INC Integrated Connectivity

Video tutorial, Software updates

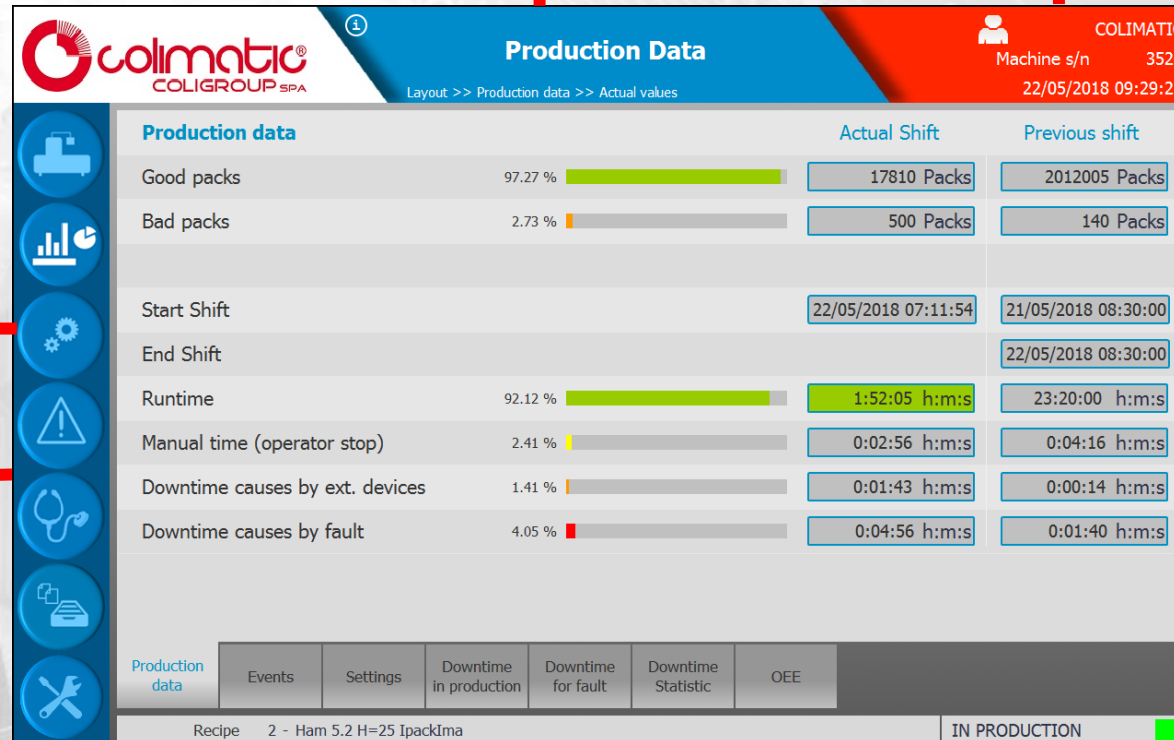

PACKAGING OF BAKERY PRODUCTS & SANDWICHES



- Sandwiches
- Pizza
- Cakes
- Bread
- Snacks
- Biscuits
- Croissant
- Piadine/Tortillas
- And more



AUTOMATIC THERMOFORMING LINES

For the packaging of **BAKERY PRODUCTS & SANDWICHES**

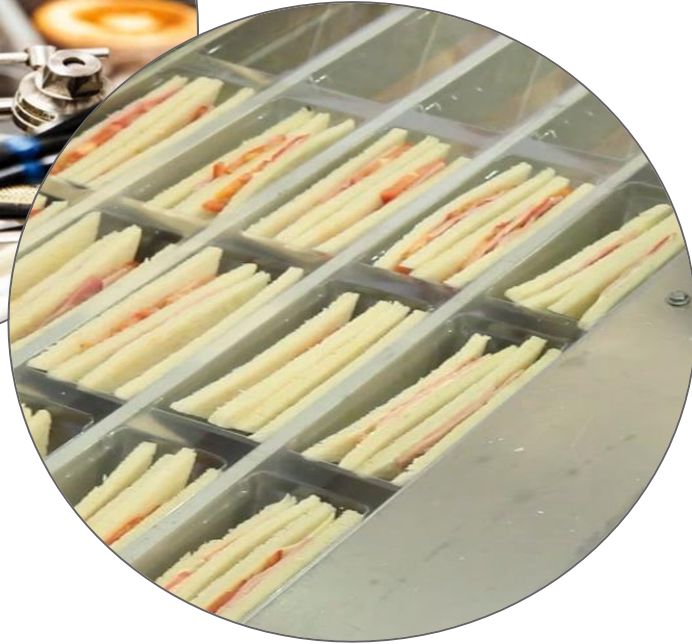

SWEET BAKERY



PASTRY AND DOUGH



SANDWICHES





EXAMPLES OF DIE CONFIGURATIONS

PIADINE/TORTILLAS

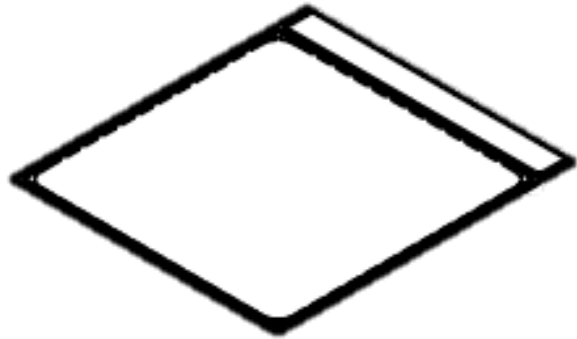

PIZZA

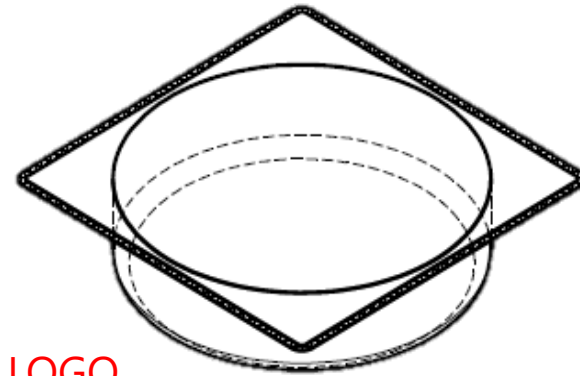

SANDWICHES

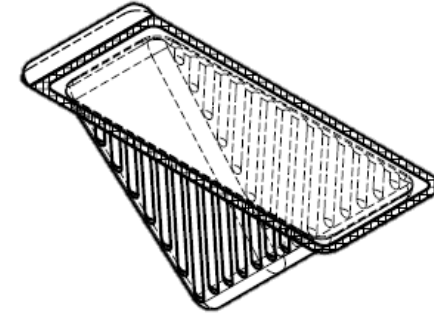

TAPAS

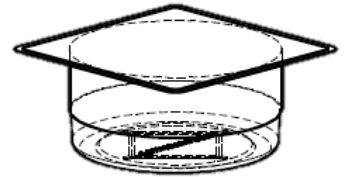

BRIOCHES

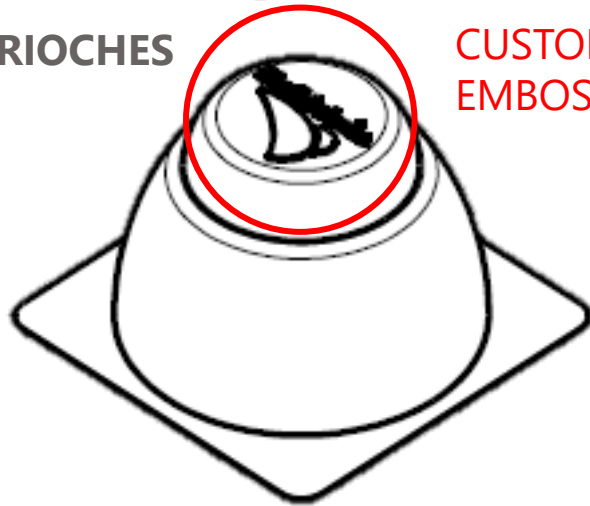

CUSTOMIZED LOGO
EMBOSSSED

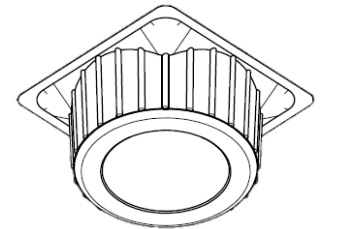
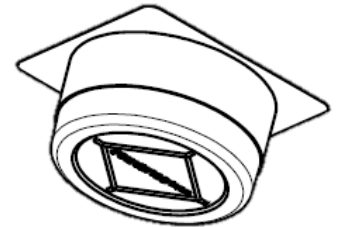
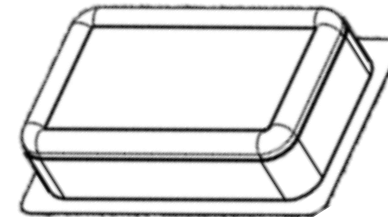
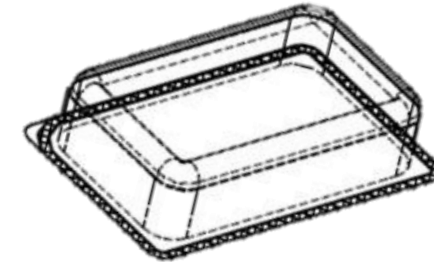
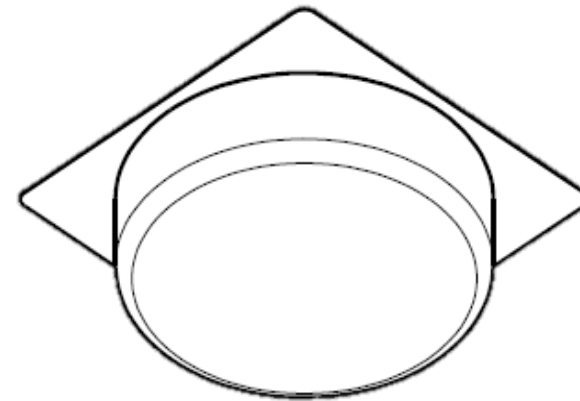

HIGH SPEED
PRODUCTIVITY
& FLEXIBILITY



COST SAVING ON
CONSUMABLES



CUSTOMER ORIENTED



CONSULTANCY



OUR CORE VALUES



RELIABILITY



HYGIENE



USER FRIENDLY



CUSTOMIZATION



CUSTOMIZATION & CONSULTANCY



PROTOTYPES MOULDS

Feasibility studies based on customers' products and technical expectations: Pilot moulds & packaging materials testing

MOULDS CUSTOMIZATION

Custom design moulds configuration

COMPREHENSIVE PACKAGING OPTIONS

Vacuum; MAP; Shrink, SKIN, Top forming & Reclosable packaging

PACKAGING MATERIALS

Our machinery is suitable to any thermoforming and/or traysealing material with thickness from 30 up to 1000my

YOUR LOGO EMBOSSED

With **customized** characters (data or logo) **embossed** on the bottom of the packs



FLEXIBILITY ON PACKAGING MATERIALS

Wide range of films with different properties and variable thickness **from 30 up to 1000 micron** depending on the application customers need.

Different **options** such as double preheating stations, plug assist and integral cutting stations should be provided in case of very thick material.

A variety of factors, e.g. type of product, forming depth, after-packing process, moisture vapor barrier, oxygen barrier, must be considered in the choice of the proper packaging material.



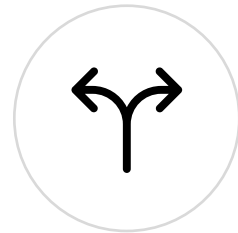

SPEED & HIGH CAPACITY

PRODUCTIVITY

Production capacity up to **22 cycles/minute**
(Depending on product and equipment)

DIE SET CHANGEOVER

Forming and sealing hinged chambers for the **fastest**
die configuration change-over (**15 minutes!**)

PNEUMATIC REEL HOLDER

Reel holders with **pneumatic** expansion lock system.
This high-value device allows a fast and easy reel change,
thus reducing costly downtimes



COST SAVINGS

Special systems for vacuum and gas injections.

Only 10mm lateral scraps and only on bottom film, with a consequent **COST SAVINGS** on packaging material

No Scraps on top film!

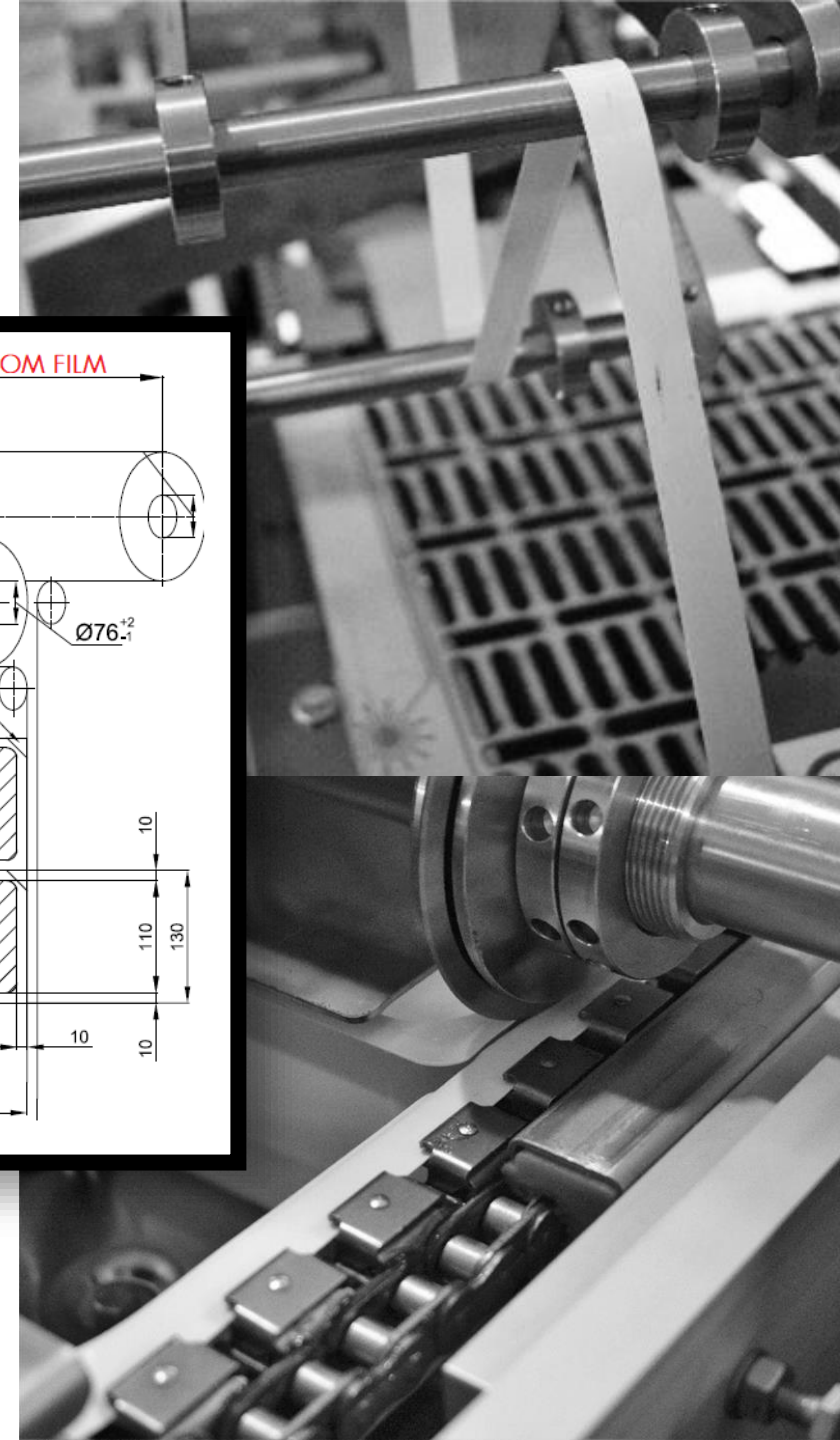
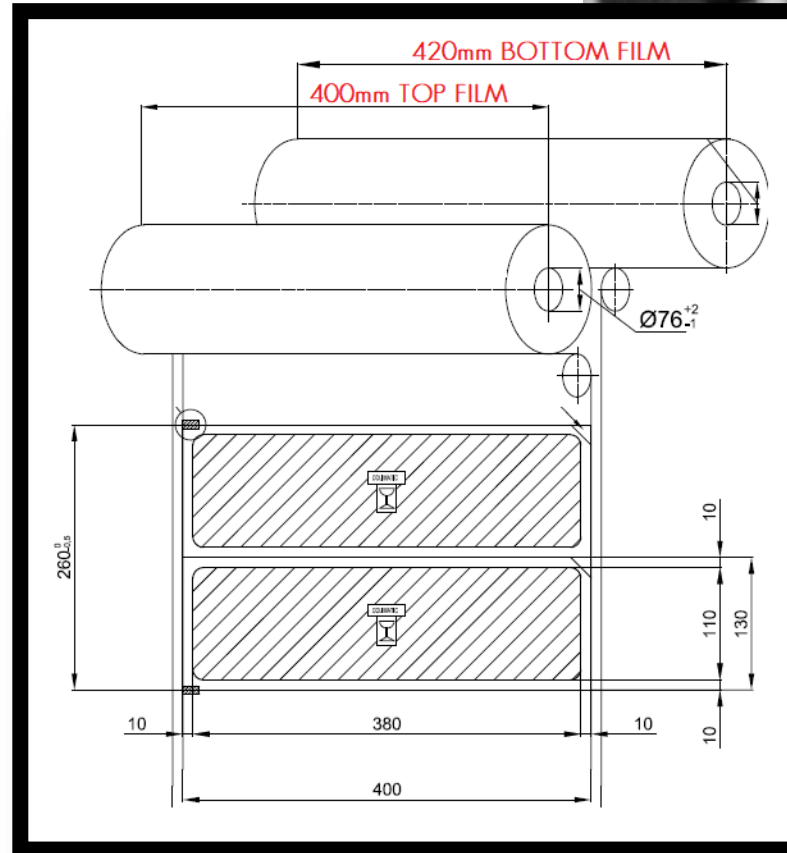



RELIABILITY



Allen-Bradley

by ROCKWELL AUTOMATION



COMPONENTS TESTING BEFORE DELIVERY

Each single component of our machines undergoes **long pre-delivery testing**

FIRST CLASS COMPONENTS

Top quality components from the most important suppliers on the market.

This is to guarantee the **highest quality** on our machines, and to let our customers free to find necessary spare parts **independently** on the market.



HYGIENE

SLANTED SURFACES

Sloped surfaces to complete washdown and draining of liquids and contaminants

VALVES

Special cabinet closed and separated in hermetic box

IP69K PANEL

HMI special hermetic closable protection

MOTORS & ENGINES PROTECTIONS

Safety covers to **protect** external motors

DURALITI & ANODIZATION

Available for special application **deep anodization** and Duraliti treatment

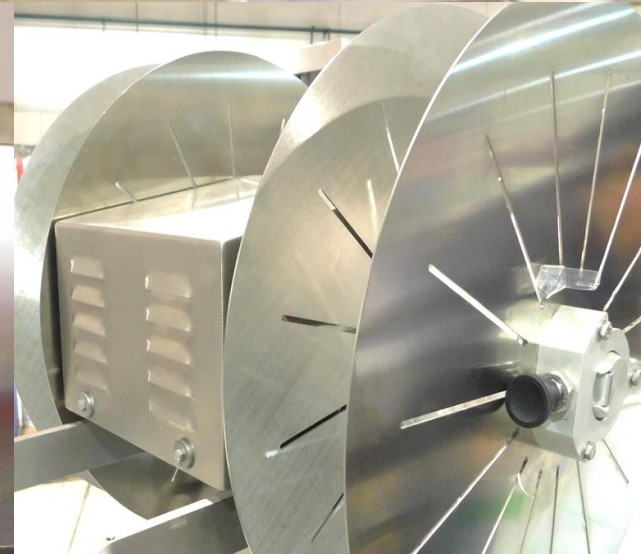
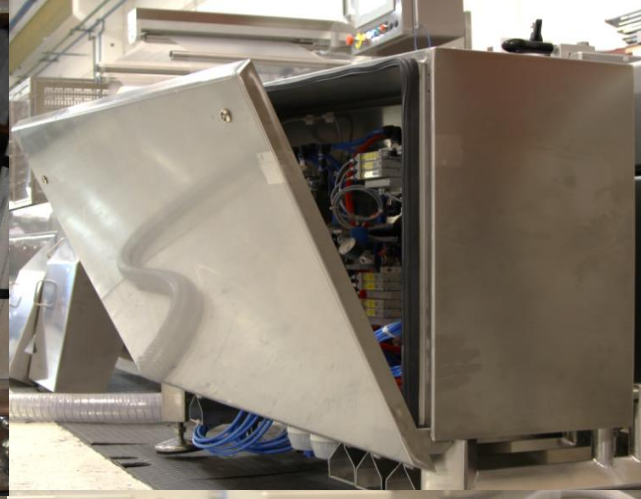
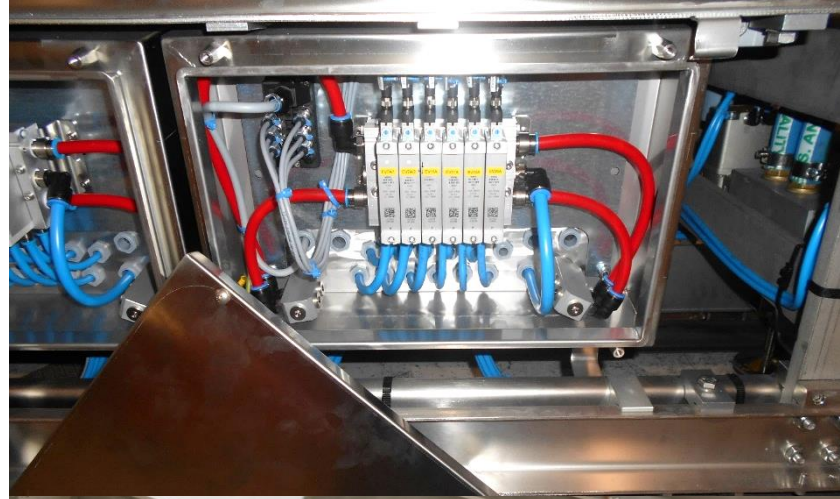



AFTER-SALES SERVICES

FAST REACTION TIMES

Local support 24/24 – 7/7

REMOTE TELE-ASSISTANCE

Our team of experts are able to access the machine control via remote service.

PREVENTIVE MAINTENANCE & SPARE PARTS

It is used to help prevent faults in advance, and to reduce unplanned downtime. Comprehensive warehouse with wide range of spare parts allow us to be prompt in case of emergency.

PERSONNEL TRAINING

Training courses on mechanics, pneumatics and electrics. We offer user training courses worldwide for our customers' operators and service personnel.

DEDICATED SHOWROOM & FAT AREA

In order to give all our customers, the opportunity to **TEST** our machinery with **THEIR OWN PRODUCTS**, while appreciating our unique technical solutions!





SMALL
ENOUGH TO LISTEN
BIG ENOUGH
TO SERVE!

THANK YOU FOR
YOUR ATTENTION



Please contact us for more details and information
backoffice@colimatic.com
www.colimatic.com

COLIGROUP SPA
Via del Lavoro Artigiano, 9
25032 Chiari (BS) - ITALY
Phone: +39 0307000761