

# FOOD AND BEVERAGE SOLUTIONS GUIDE

Safeguard Inspections, Improve Quality, and Protect Your Brand

**COGNEX**

# THE RIGHT CHOICE FOR FOOD AND BEVERAGE APPLICATIONS

## PROTECT YOUR CUSTOMERS. PROTECT YOUR BRAND.

With lean operations and thin margins, the pressure on the food and beverage industry to optimize overall equipment efficiency (OEE) without compromising quality is challenging. Successful manufacturers embrace machine vision and barcode reading solutions to minimize downtime and consistently deliver safe, high quality products that are easily traced throughout the supply chain. With the widest selection of machine vision systems and barcode readers, Cognex solutions help food and beverage manufacturers solve some of the most challenging inspection, verification, and tracking applications.

Take Your Operations to the Next Level with Machine Vision and AI.....	3
Digitalization and Self-Regulation .....	4
Product Quality Inspection .....	5
Packaging Inspection .....	8
Assembly Verification .....	11
Allergen Management and Traceability .....	14
Warehousing and Distribution .....	15
Cognex AI.....	17
Cognex Global Services.....	18

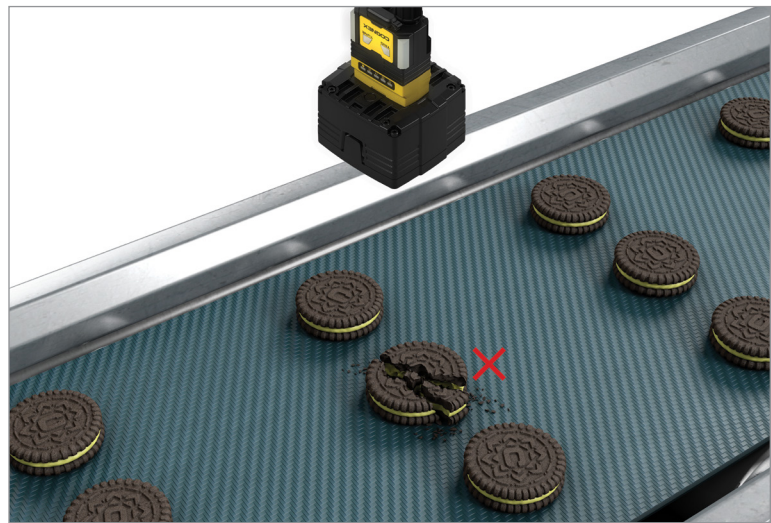
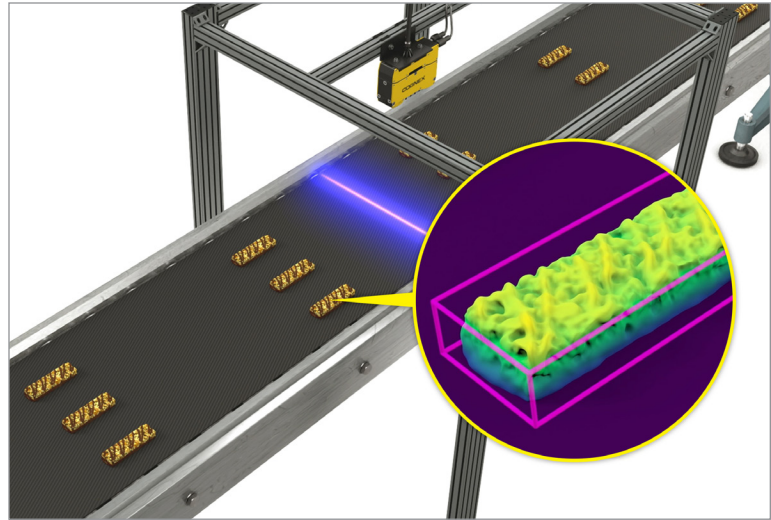

# TAKE YOUR OPERATIONS TO THE NEXT LEVEL WITH MACHINE VISION AND AI

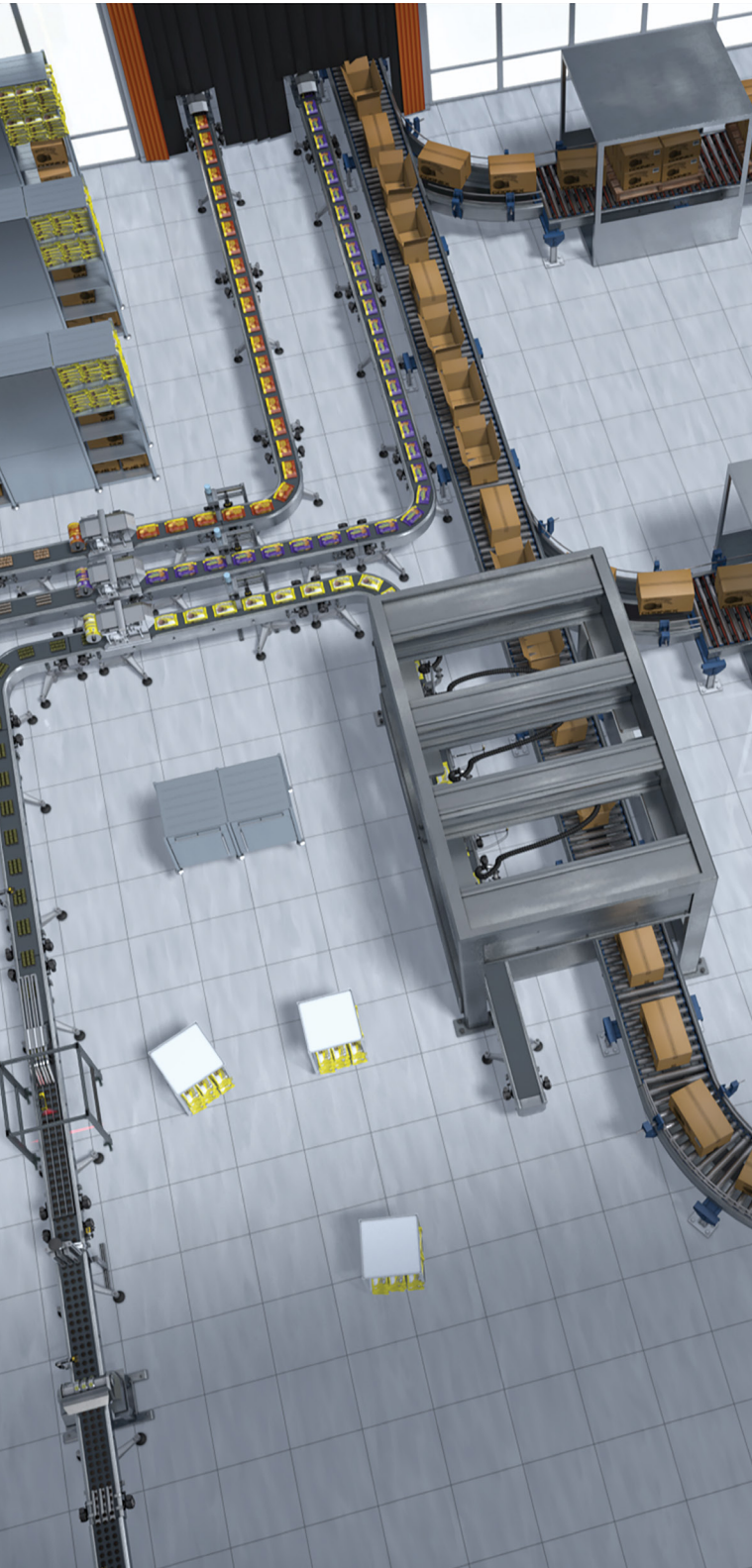

## INCREASE THROUGHPUT AND OEE

Accommodate fast and frequent line changeovers and increase the throughput, efficiency, reliability, line speeds, and versatility of your production lines.

## IMPROVE PRODUCTIVITY AND DRIVE DOWN COSTS

Achieve greater consistency, precision, safety, and output to drive down manufacturing overhead and avoid costly, time-consuming rework.

## PROTECT YOUR BRAND

Avoid having spoiled or damaged goods reach the market. Prevent defects and ensure quality to keep customers satisfied and your brand reputation protected.

## REDUCE SCRAP

Achieve your zero waste goal with smarter automation. Detect mislabeled, wrongly assembled, and defective products early in the production process to reduce scrap and avoid stoppages and downtime.

**“Given the current high costs of raw ingredients and energy, this vision system really does drive down waste figures at this plant thus increasing overall production and reducing costs.”**

—Niall Reilly, Senior Software Engineer at Frank Roberts

# DIGITALIZATION AND SELF-REGULATION

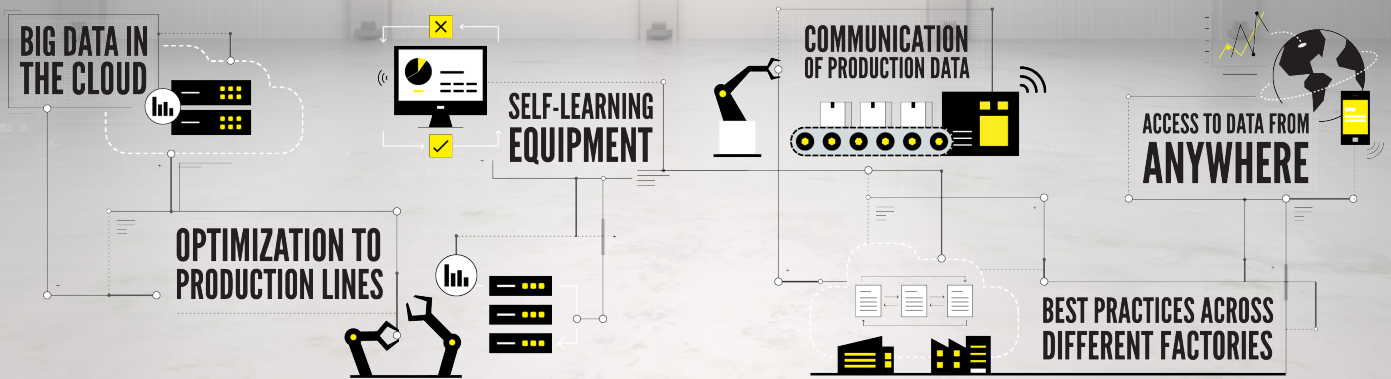

Industry 4.0 is driving change in the packaging industry as manufacturers seek to capitalize on emerging innovations in advanced automation. Machine vision, Big Data, cloud computing, and machine learning are revolutionizing manufacturing processes. Moving along the journey to Industry 4.0 presents an opportunity to digitalize processes that bolster productivity, reduce waste, improve product quality, enhance manufacturing flexibility, and decrease operating costs. Implementing a digitalization strategy also presents an opportunity to address ongoing labor shortage challenges.

As Industry 4.0 compatible edge systems and devices, Cognex machine vision and AI-based solutions create valuable digital data that serves two purposes. First, these systems capture real-time information such as inspection and measurement data that facilitates automatic in-line quality decisions. In addition, companies see great value in either feeding this data back into the process in real time or aggregating this data over time, performing off-line analytics, and using the resulting insights to drive process improvement and predictive maintenance. Cognex vision systems facilitate the digitalization of quality control processes through easy integration into industrial networks via standard communication and file transfer protocols such as TCP/IP, PROFINET, EtherNet/IP, SLMP, OPC/UA, and FTP.

## SAMPLE USE CASE

The packaging industry is trending towards increased use of sustainable or recycled materials, which can be highly variable in their composition and appearance within a given production run. Given these variations, it is challenging to maintain consistent printing quality and contrast of valuable label information, such as regulatory codes and ingredients. To overcome this challenge, a machine vision or AI-based system can provide inspection data in a closed loop process with the marking system so it can automatically respond to the variations in contrast by adjusting the marking pressure in real time.

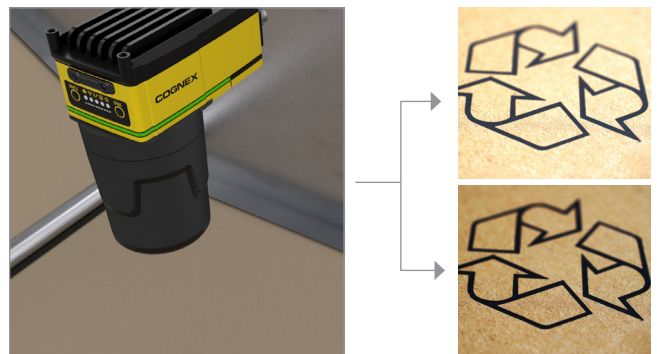

# PRODUCT QUALITY INSPECTION

Products can break or become damaged during production. Inspecting for product integrity prior to packaging is critical to ensure customer satisfaction and protect brand reputation. Cognex identifies defects and rejects them before they reach the customer, protecting your company's brand against the net effect of damaged goods while avoiding stoppages and downtime.

## 3D Final Product and Packaging Inspection

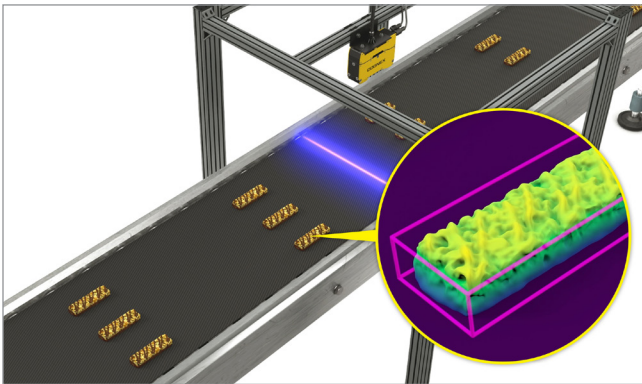

3D vision systems inspect food elements for damage and confirm dimensions and volume.

## Chewing Gum Inspection

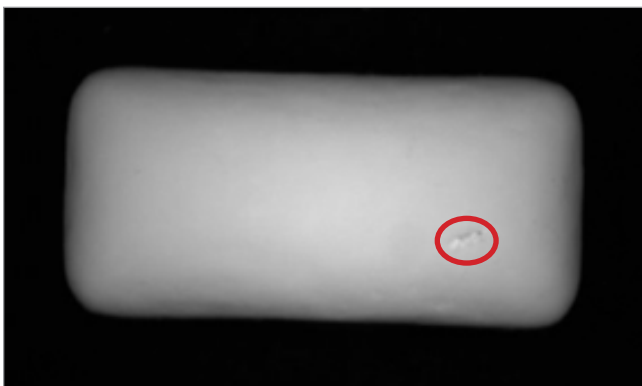

AI tools detect cosmetic defects among large numbers of small, curved items, such as chewing gum.

## BENEFITS

- Detect damaged products
- Reduce costly downtime and manual intervention
- Avoid packaging mix-ups
- Preserve customer loyalty

## Assorted Chocolate Box Quality Inspection

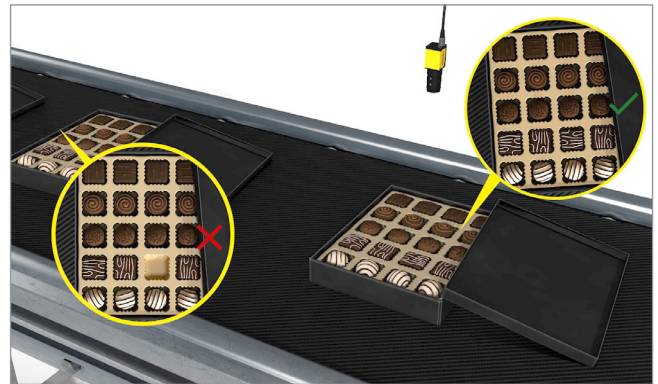

AI tools ensure all pieces in an assortment are present and undamaged.

## Coffee Bean Inspection



AI-based solutions classify coffee beans to ensure the right varieties are used in blends.

## Foreign Object Inspection



AI-powered technology ensures food and beverage products are contaminant-free.

## Portioning Inspection

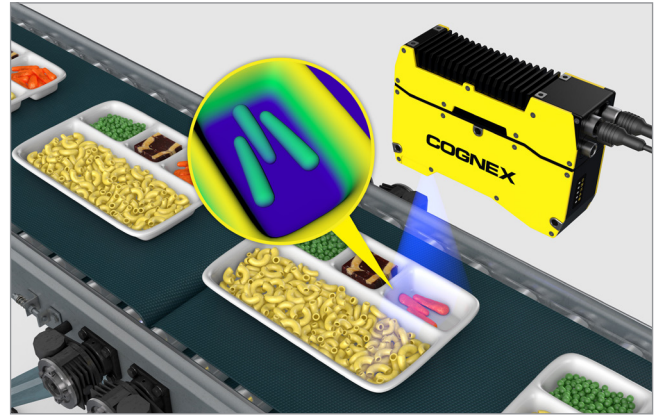

3D displacement technology inspect portion sizes prior to packaging.

## Shelled Nuts Inspection and Sorting

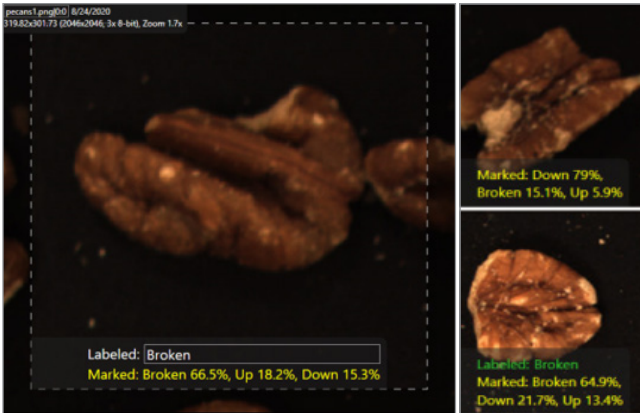

AI-enabled vision systems and software classify and identify acceptable nuts for placement on chocolates.

## Product Consistency Inspection

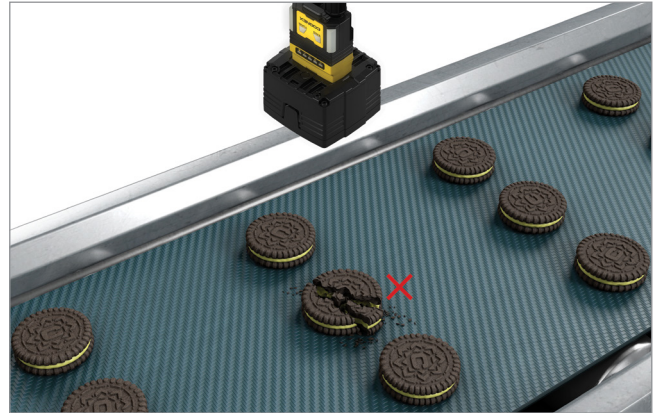

Machine vision systems detect damage and ensure consistency in size, shape, color, and texture.

## Packaging Match Inspection



Machine vision systems ensure packages contain their correct contents.

## Conveyor Belt Inspection

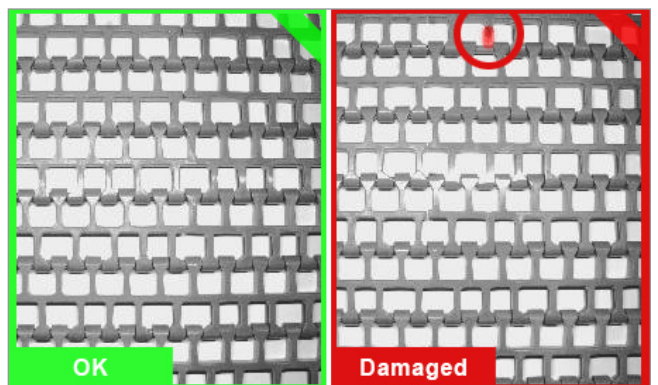

Continuous visual belt inspection uses AI-enabled technology to reduce the risk of food contamination due to undetected broken belt links.

## Automated Meat and Poultry Inspection

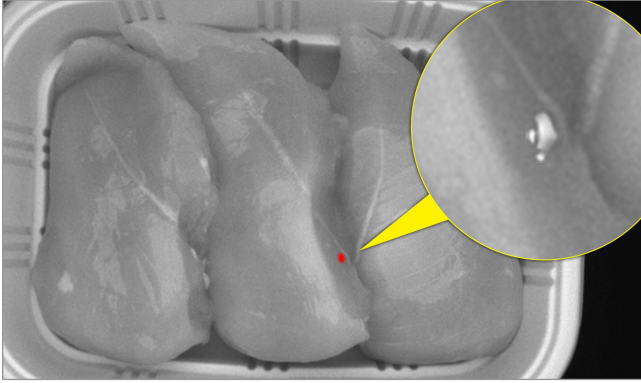

AI-based technology detects physical contamination on meat and poultry.

## Chicken or Turkey Inspection/Grading



AI-based vision systems identify missing legs or wings, inspect for tearing, bruising, and color.

## Beef or Pork Inspection/Grading



AI-enabled technology inspects color and calculates lean to fat content.

## Classifying Meat for Sortation

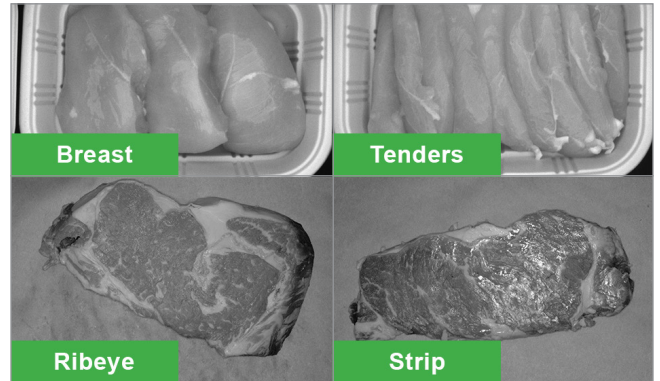

AI-based vision systems identify and classify cuts of poultry or beef to prevent mislabeling.

## Lunch Meat Slicing Inspection

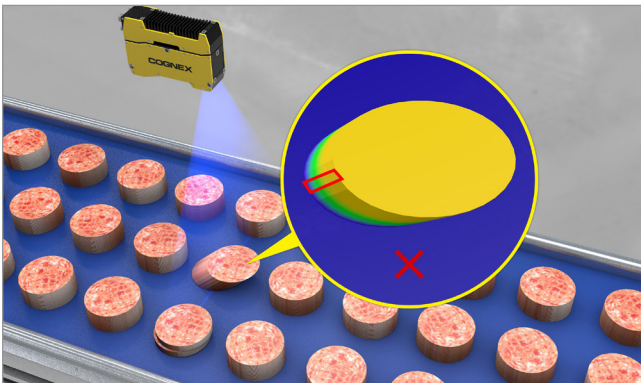

3D vision systems verify straightness of deli meat stacks to reduce rips and tears during packaging. 2D vision systems classify deli meat by type.

## Volumizing Meat for Cooking Prior to Packaging

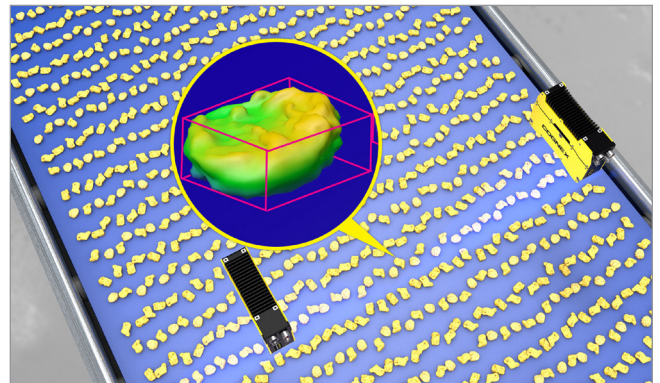

3D displacement technology ensures product meets size and dimension requirements to ensure even cooking.

# PACKAGING INSPECTION

Packaging affects consumer perception of product quality, safety, and value. Cognex vision systems inspect food packaging to ensure it is correctly assembled, defect free, and complete, so that only the highest quality products reach customers.

## Aluminum Can Inspection

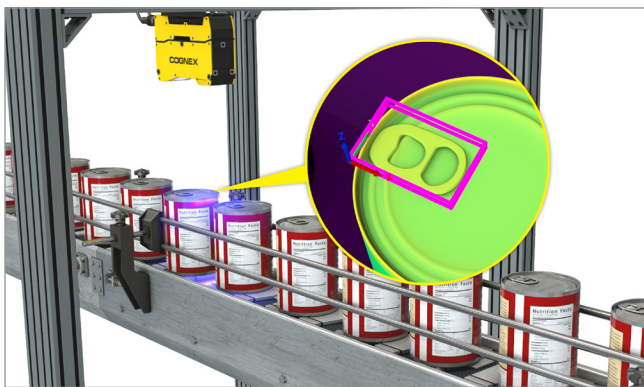

3D laser imaging technology quickly inspects aluminum cans on high-speed lines for defects.

## Glass Jar Neck Inspection

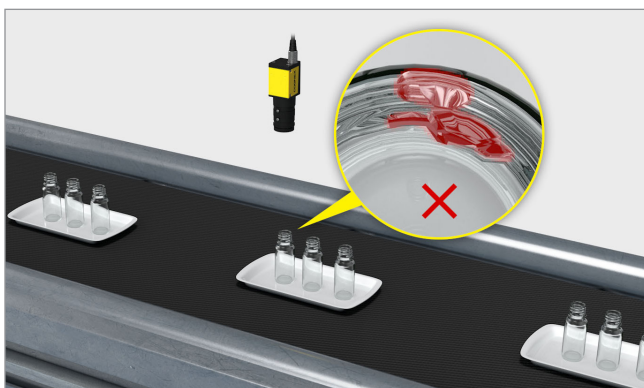

AI-enabled technology detects variable defects in threaded necks of glass containers.

## BENEFITS

- Avoid unsightly, damaged packaging
- Defend against contamination and spills
- Prevent returns from wholesalers and retailers
- Preserve brand reputation

## Food and Beverage Case Code Reading



AI-based OCR solutions read date and lot codes on case packaging against varying backgrounds.

## Code Reading on Flexible Food Packaging

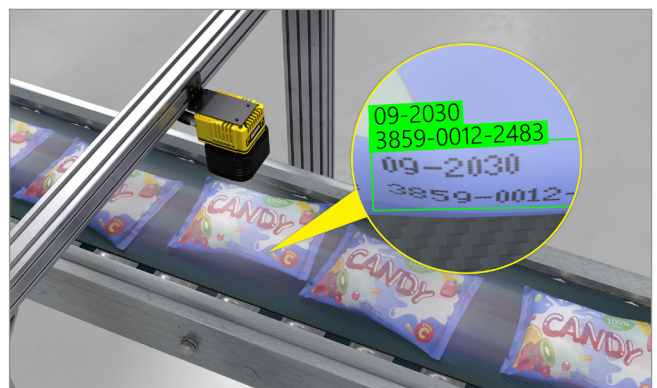

Accurately decipher human-readable codes on flexible food packaging with AI-based OCR solutions.



## Product Orientation Inspection

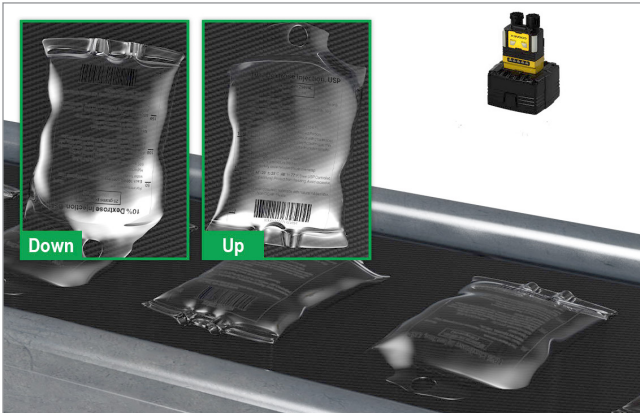

Edge learning solutions ensure prepacked liquid-filled bags are shipped the correct side up.

## Tea Bag Carton Inspection

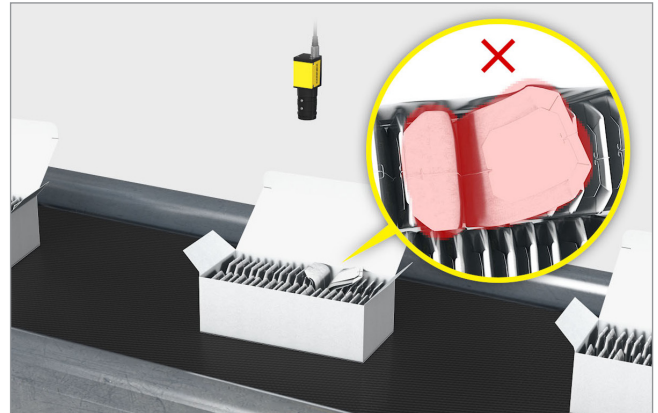

AI-powered technology ensures that tea bags and cartons are correctly packed.

## Package Seal Inspection

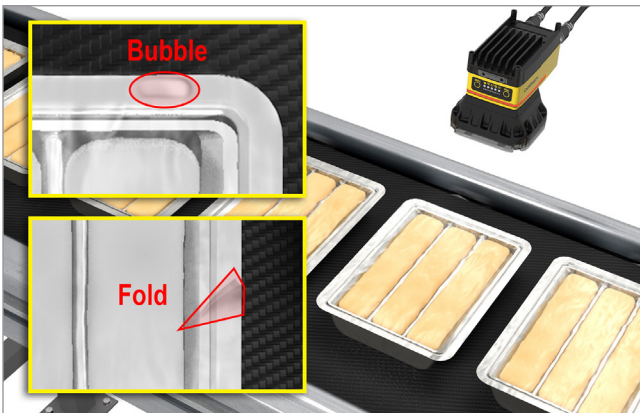

AI tools identify foreign matter and contaminants that impact the integrity of product seals.

## Tamper-Proof and Safety Seal Inspection



Machine vision technology detects safety seal defects and limit product recalls.

## Cosmetic Defect Detection

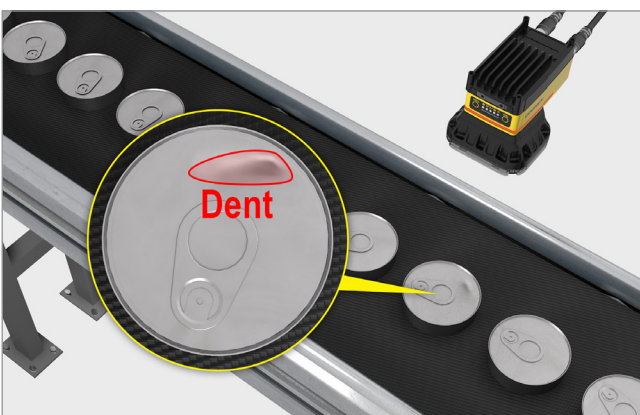

AI-based vision systems and software identify defects on challenging food and beverage packaging surfaces.

## Label Quality Inspection



In-Sight® 2D vision systems with edge learning tools identify and classify various label defects.

## Skewed Label Inspection



In-Sight 2D vision systems ensure food or beverage product label alignment is correct.

## Date/Lot Code Inspection



In-Sight 2D vision systems with OCRMax™ technology read alphanumeric date and lot codes to verify compliance.

## High-Speed Barcode Reading

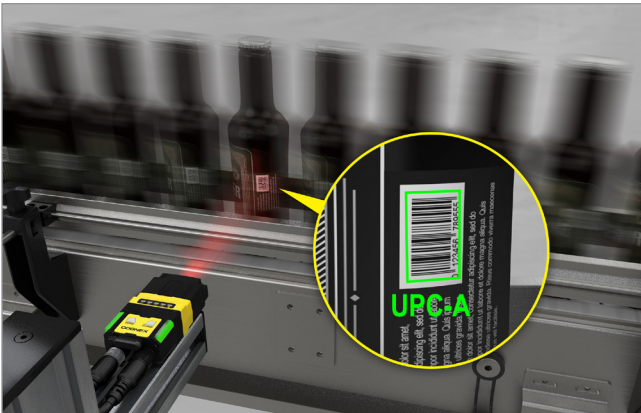

DataMan® barcode readers quickly and accurately read product barcodes, regardless of condition or location.

## Barcode Quality Inspection



Barcode verifiers reliably grade barcodes to assure GS1 label quality.

## Seal and Label Inspection

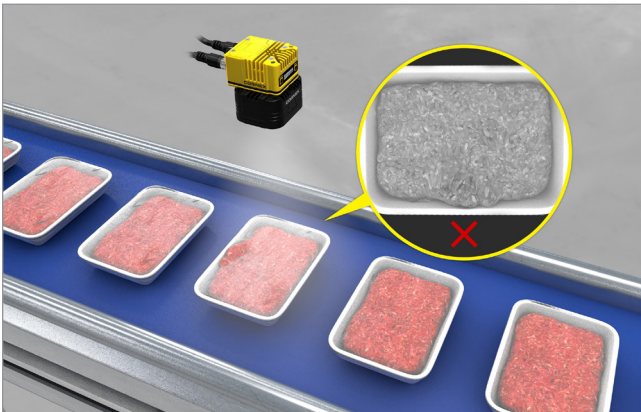

AI-based vision systems check the integrity of film seals on trays and read product labels and codes to prevent mislabeling.

# ASSEMBLY VERIFICATION

Identifying assembly defects early saves significant time and money, especially when a single failure can affect an entire batch. Vision-guided quality checks ensure completeness and consistency while robotic pick-and-place capabilities speed up and error-proof the transition from production to packaging.

## Cookie Counting Verification

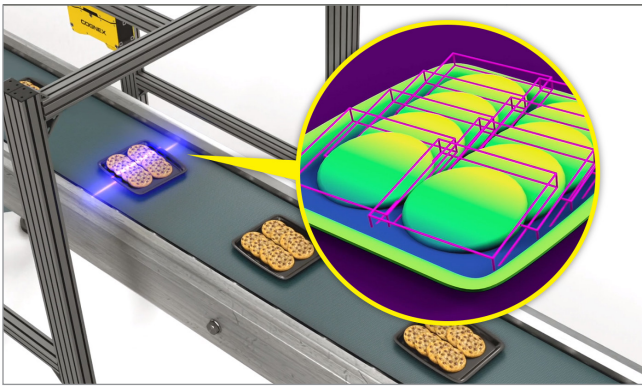

3D vision systems and tools accurately count food objects for proper portioning.

## Missing Item Inspection



In-Sight 2D vision sensors detect the presence or absence of objects during final assembly.

## BENEFITS

- Detect defects and missing items
- Verify completeness and product integrity
- Enable vision-guided robotics
- Improve pick times and accuracy

## Fill Level Inspection



In-Sight 2D vision systems measure liquid volume for proper filling.

## Pick and Place Carton Packing

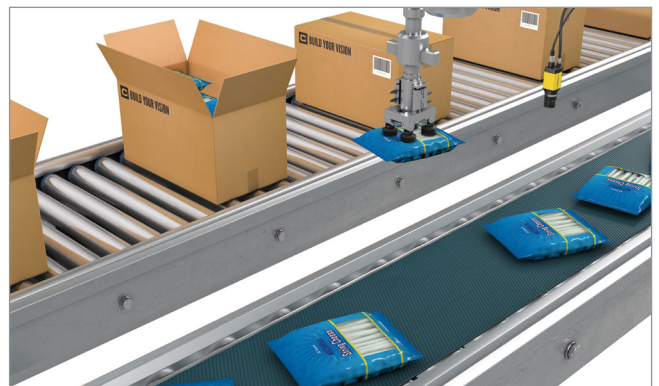

In-Sight 2D vision systems locate and identify objects for pick-and-place robotic packing.

## Frozen Pizza Sorting and Inspection

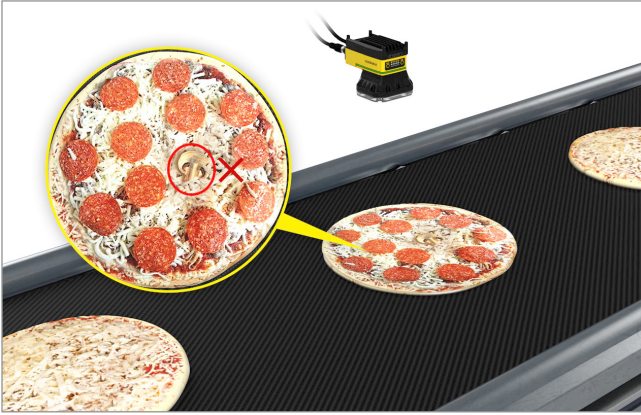

AI-based technology confirms pizza type, proper ingredients, and absence of physical contaminants.

## Robotic Pick and Place Tray Packing

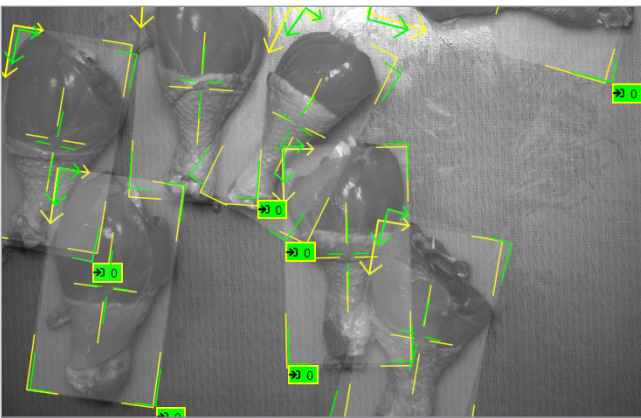

AI-powered vision systems identify meat cuts on conveyor, classify good or bad items, and locate coordinates for robotic picking.

## Verifying Meat/Poultry Portions

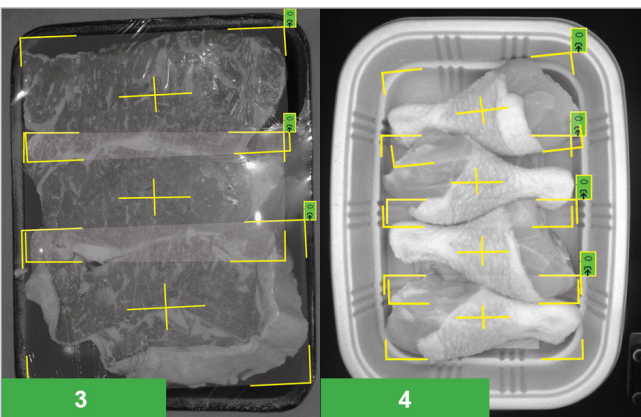

AI-powered vision systems verify proper package contents by counting meat or poultry items on trays or in clear bags.

## COGNEX AI

Cognex AI-based technology mirrors human intelligence to distinguish anomalies, locate deformed parts, and read challenging characters while tolerating natural variations in complex patterns. AI complements traditional machine vision approaches, which struggle to appreciate variability and deviation between visually similar parts.

These powerful solutions automate a range of applications including defect detection, assembly verification, part location, optical character recognition, and more.

### Find and count complex features and objects



### Classify and sort objects and complete scenes

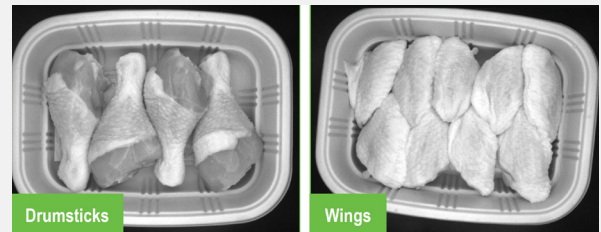

### Detect anomalies and cosmetic defects

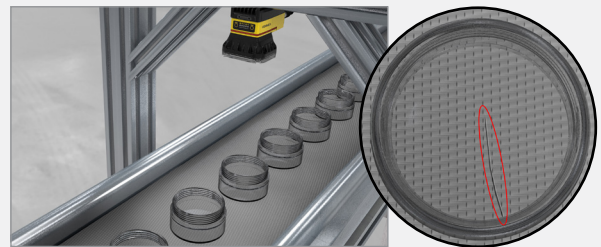

### Read challenging, deformed characters

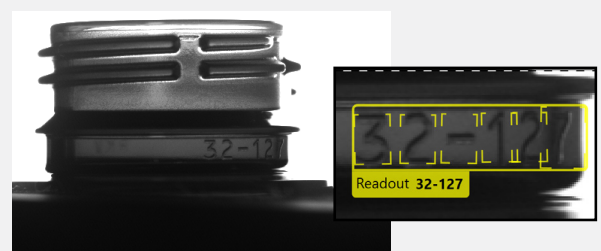

## Chocolate Assembly Verification

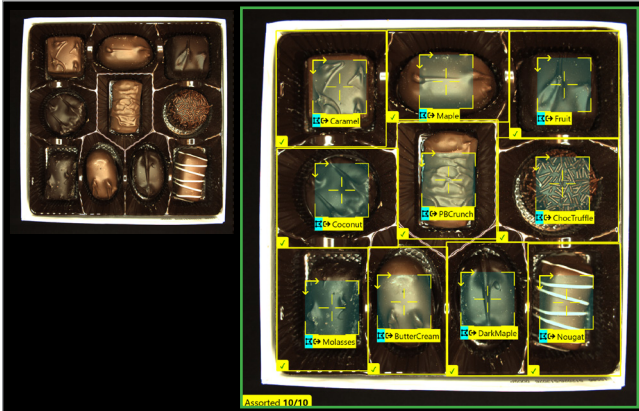

AI-powered solutions identify, count, and verify that chocolates are assembled and packaged properly.

## Bottle Cap Inspection



In-Sight 2D vision systems with edge learning capabilities verify caps are properly placed and sealed.

## Verify Presence of Scoops in Food Containers

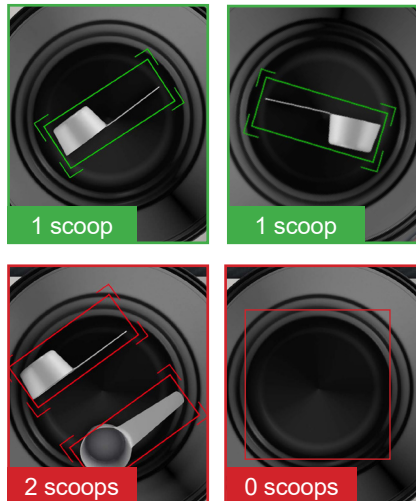

In-Sight vision systems with edge learning technology verify the absence or presence of scoops in powdered food product.

## Juice Box Quality Inspection



In-Sight 2D vision systems with edge learning capabilities identify and classify juice box packaging defects.

# ALLERGEN MANAGEMENT AND TRACEABILITY

Mislabeled allergens threaten the public's health and can cause expensive recalls deeply damaging to brands. Regulations in the US and abroad require manufacturers to label and trace common allergens. To ensure product safety and efficient recalls, manufacturers must be able to quickly identify and locate faulty products in the supply chain posing hazards to consumers. Cognex machine vision and image-based barcode readers verify your ingredients are labeled correctly, while track-and-trace solutions prevent packing mistakes and help locate recalled items quickly to minimize loss.

## BENEFITS

- Identify and locate defective products
- Prevent accidental exposure and liability
- Limit the risk of recalls
- Comply with regulatory standards
- Deter counterfeiting

## Allergen Label Inspection



In-Sight 2D vision systems inspect for the presence or absence of allergen labels and verify label accuracy.

## Mislabeled Packaging Inspection



AI-based OCR solutions quickly read alphanumeric codes on multi-part packaging to ensure components match.

## Packaging Traceability



In-Sight vision systems and OCR vision tools read alphanumeric date/lot codes to ensure supply chain traceability.

## Anti-Counterfeiting



DataMan barcode readers accurately read serialization and UV codes to authenticate food and beverage products.

# WAREHOUSING AND DISTRIBUTION

Increasingly, food and beverage products are being manufactured, warehoused, and distributed from the same location. Manufacturers must optimize not just their production capacity and quality, but also their warehousing and fulfillment operations to meet growing performance criteria and customer demands. Cognex vision systems and image-based barcode readers have the highest read-rates in the industry and can dramatically increase the speed, accuracy, and productivity of warehouses and distribution centers.

## Multiple Barcode Reading and Pallet Scanning



DataMan barcode readers combined with High-Speed Steerable Mirror simultaneously read multiple codes on pallets.

## Automated Sorting



DataMan barcode readers quickly read barcodes at various heights and angles to facilitate automatic sorting.

## BENEFITS

- Streamline item processing and sorting
- Receive, store, and retrieve inventory efficiently
- Minimize rework and downtime
- Lower maintenance costs

## ANY CODE, EVERY TIME

2DMax<sup>®</sup> with PowerGrid<sup>®</sup> reads 2D codes with significant damage to or complete elimination of a code's finder or clocking pattern, or quiet zone.

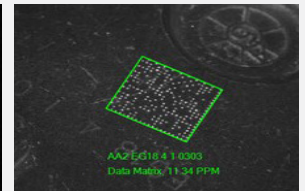
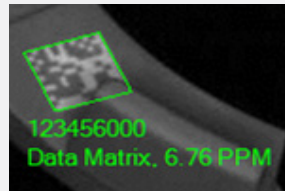

1DMax<sup>™</sup> with Hotbars<sup>®</sup> is an algorithm and technology optimized for omnidirectional 1D barcode reading, decoding up to 10X the speed of a conventional barcode reader.

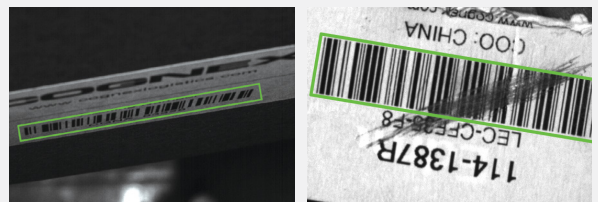

OCRMax<sup>™</sup>, a font-trainable optical character recognition and verification (OCR and OCV) tool, has set industry records for ease of use, read rates and speed in complex images. This powerful algorithm prevents misreads, handles process variations, and provides easy font management.

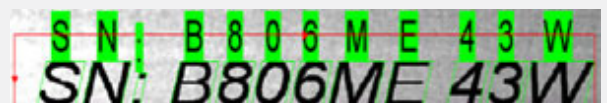

## Robotic Palletization with Label Verification



In-Sight 2D vision systems verify 2D and alphanumeric codes on cartons and guide robotic arm for palletizer.



# COGNEX AI

Cognex AI learns to spot patterns and anomalies from example images. It solves tasks that are too complicated and time-consuming to program with rule-based algorithms, while providing a consistency and speed that aren't possible with manual inspection.



## Edge learning: Designed for ease of use

Edge learning is a subset of AI in which processing takes place on-device, or "at the edge," using a pre-trained set of algorithms. The technology is simple to setup, requiring smaller image sets and shorter training and validation periods than traditional deep learning-based solutions.

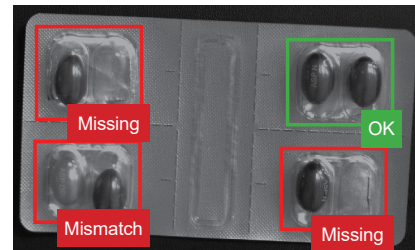

## Deep learning: Designed for complex applications

Capable of processing large, detailed image sets, deep learning is designed to automate complex or highly customized applications. The technology enables users to analyze vast image sets quickly and efficiently, while differentiating between acceptable and unacceptable anomalies, to deliver accurate results.

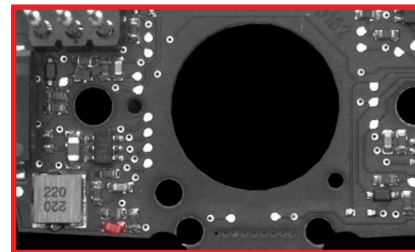
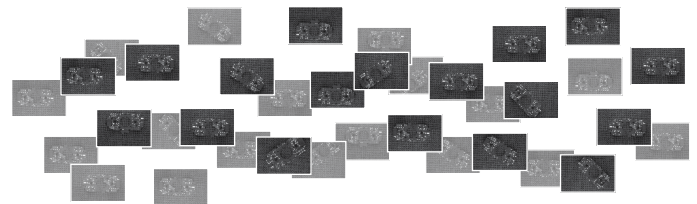

## Cognex AI resources



Watch *Machine, Deep, or Edge Learning: What's the Difference?*

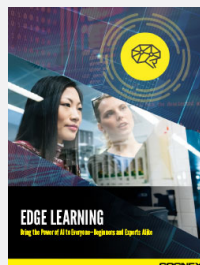

Read *Edge Learning: The Power of AI for Everyone*

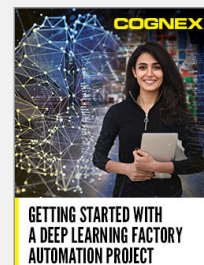

Read *Getting Started with a Deep Learning Factory Automation Project*

# COGNEX GLOBAL SERVICES

Technical Support ▪ Product Training ▪ Self-Service Portal ▪ Lifecycle Management

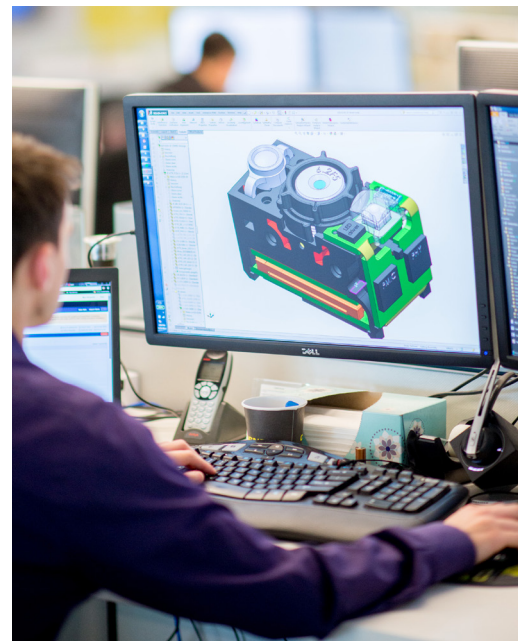

Cognex serves an international customer base from offices located throughout the Americas, Europe, and Asia and through a global network of highly-trained partners, system integrators, and distributors.

From development to deployment, Cognex is there to get your vision systems up and running as fast as possible. Whether you're considering machine vision for the first time or are already an expert user, Cognex global services provide the expertise to help your organization succeed.

[www.cognex.com/support/cognex-services](http://www.cognex.com/support/cognex-services)

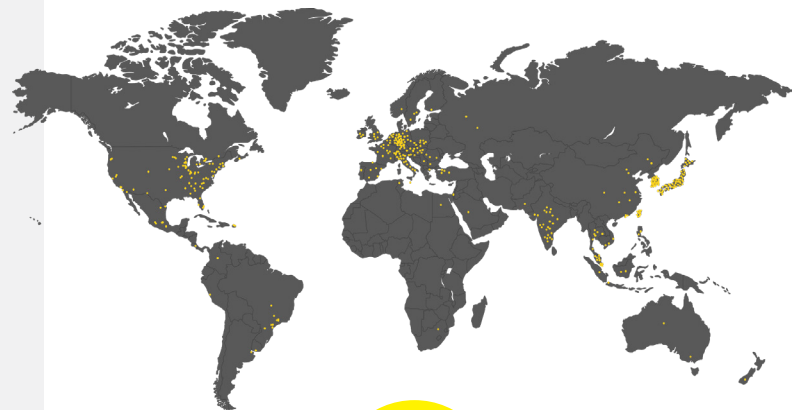

Offices in **20+** countries

**500+** Global partners in 30 countries

# THE GLOBAL LEADER IN MACHINE VISION AND BARCODE READING

For over 40 years, Cognex has helped the world's most innovative companies make their manufacturing and distribution faster, smarter, and more efficient.

Cognex vision systems and barcode readers help customers improve product quality and operational performance by eliminating defects, verifying assembly, and tracking information at every stage of the production process. Using data captured by Cognex vision systems and barcode readers, companies can monitor, update, and change production plans in real-time across global supply chains.

Smarter automation using Cognex products means fewer errors, which equates to lower costs and higher customer satisfaction. And Cognex is constantly applying new techniques, like artificial intelligence, to enable companies to evolve their automation strategy to meet today's and tomorrow's needs.

With a wide range of solutions and a large network of global vision experts, Cognex makes it possible to **Build Your Vision.**™

## \$1 BILLION

### 2022 REVENUE

## OVER 42

YEARS IN THE BUSINESS

## 500+

CHANNEL PARTNERS

## GLOBAL OFFICES IN 20+ COUNTRIES

## 4,000,000+ SYSTEMS SHIPPED

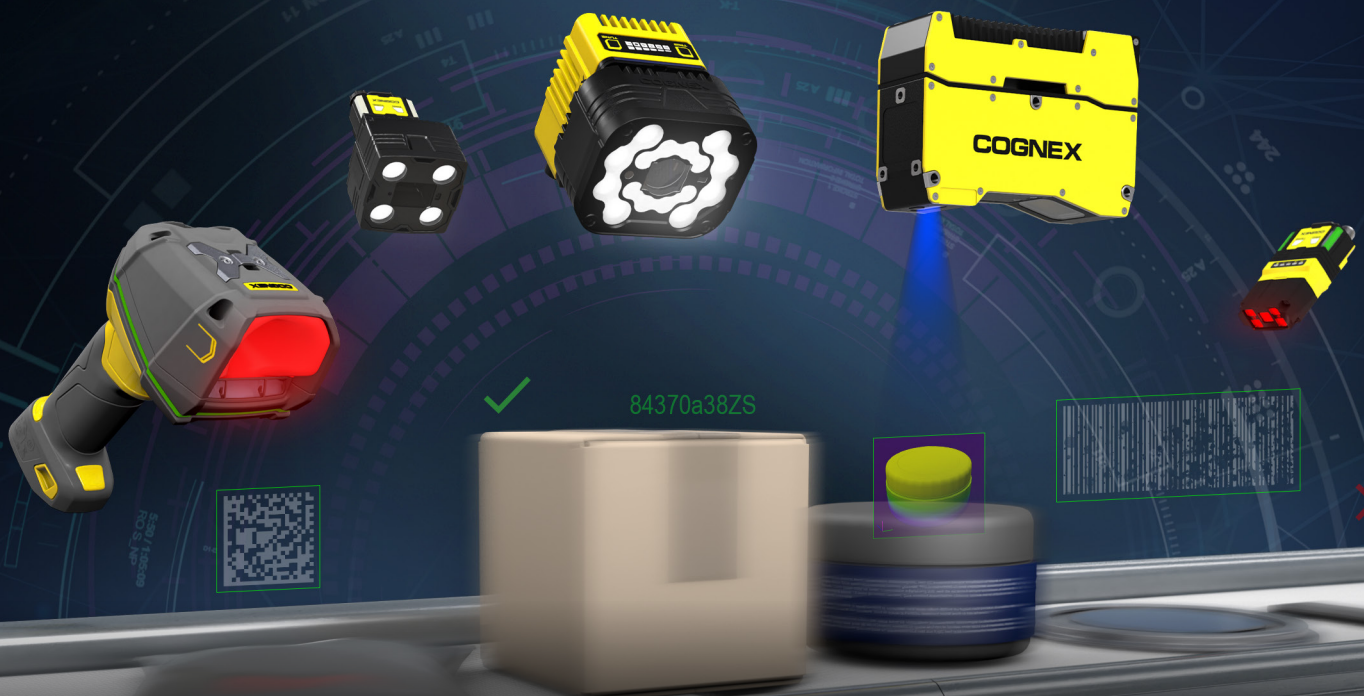

# BUILD YOUR VISION

## Vision Systems

Automate inspection tasks, from defect detection to assembly verification and text reading, with easy to deploy vision systems.

[www.cognex.com/machine-vision](http://www.cognex.com/machine-vision)



## Barcode Readers

Track and trace, from the floor to dock door, with powerful readers and verifiers designed to handle any code type.

[www.cognex.com/barcodereaders](http://www.cognex.com/barcodereaders)



## Industry Solutions

Solve applications across a wide range of industries with flexible and reliable machine vision and barcode reading solutions.

[www.cognex.com/solutions](http://www.cognex.com/solutions)



# COGNEX

Companies around the world rely on Cognex vision and barcode reading solutions to optimize quality, drive down costs and control traceability.

Corporate Headquarters One Vision Drive Natick, MA 01760 USA

### Regional Sales Offices

#### Americas

North America +1 844 999 2469  
Brazil +55 11 4210 3919  
Mexico +800 733 4116

#### Europe

Austria +43 800 28 16 32  
Belgium +32 289 370 75  
Czechia +420 800 023 519  
France +33 1 76 54 93 18  
Germany +49 721 958 8052  
Hungary +36 800 80291

Ireland +353 21 421 7500  
Italy +39 02 3057 8196  
Netherlands +31 207 941 398  
Poland +48 717 121 086  
Romania +40 741 041 272  
Spain +34 93 299 28 14  
Sweden +46 21 14 55 88  
Switzerland +41 445 788 877  
Turkey +90 216 900 1696  
United Kingdom +44 121 29 65 163

#### Asia-Pacific

Australia +61 2 7202 6910  
China +86 21 2279 9455

India +91 7305 040397  
Indonesia +62 21 3076 1792  
Japan +81 3 5977 5400  
Korea +82 2 539 9047  
Malaysia +6019 916 5532  
New Zealand +64 9 802 0555  
Philippines +63 2 8539 3990  
Singapore +65 3158 3322  
Taiwan +886 02 7703 2848  
Thailand +66 6 3230 9998  
Vietnam +84 98 2405167

© Copyright 2023, Cognex Corporation.  
All information in this document is subject to change without notice. All Rights Reserved.  
Cognex, In-Sight, and DataMan are registered trademarks of Cognex Corporation. OCRMax is a trademark of Cognex Corporation.  
All other trademarks are property of their respective owners.

Lit. No. FB5G-06-2023

[www.cognex.com](http://www.cognex.com)