

Palletizing Robot Cell

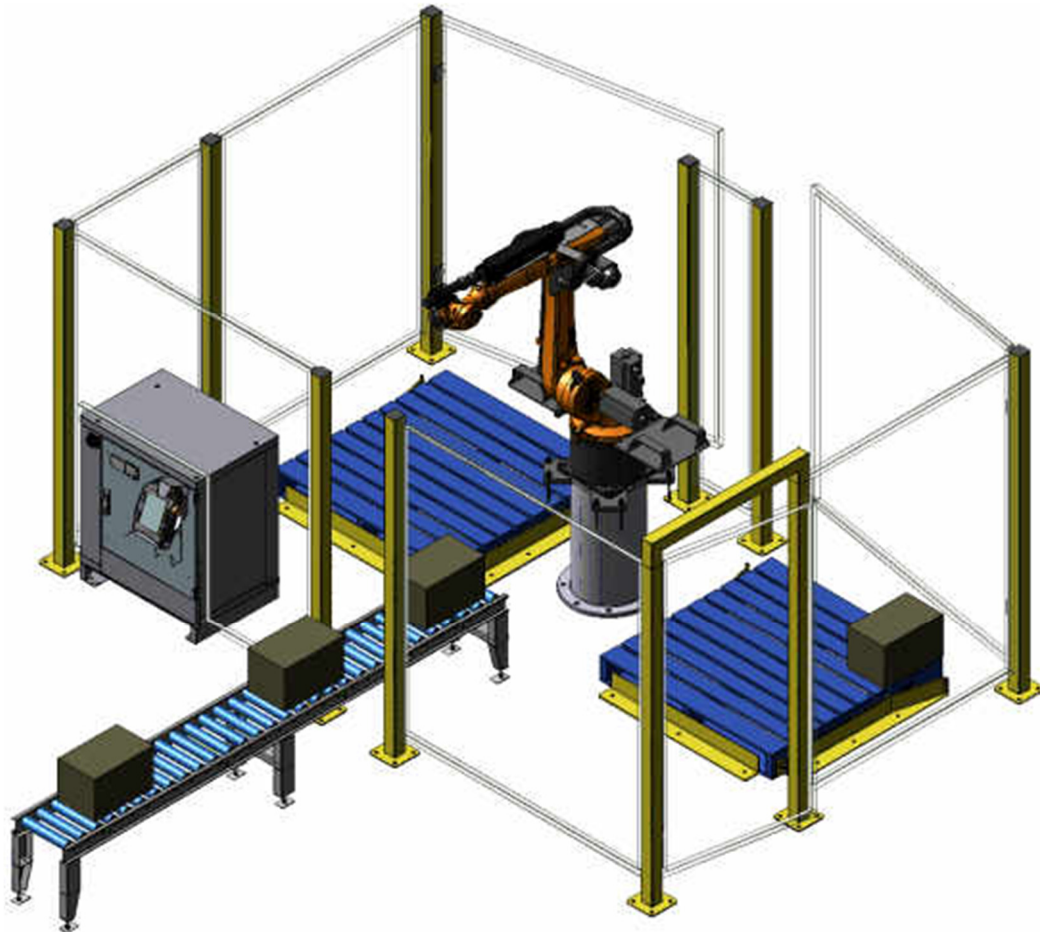

Single or multiple pallet cells

**Pallet dispensers, pallet transfer networks, infeed
conveyors - Guarding**

Automatic pallet wrappers

High speed or collaborative robots

6 axis or Linear gantry or portal type

Talk to us about your requirements !

Fully installed robot cells for an economical cost

68 Lancaster Drive Goonellabah NSW 2158 • Phone: 1300 554 599 • Mobile: 0417 339 571 (Factory)

Email: sales@profauto.com.au (Australia & NZ)

Website: www.profileautomation.com.au • www.profauto.com.au • www.mitchellindustries.com

Features

- High speed robot
- EOAT (end of arm tool)
- HMI interface
- Easy configuration
- Recipe for stack configurations
- 2m Perimeter safety fencing
- Access door and Pallet gates or Light curtains
- 2 ~ 3-meter infeed conveyor or to specification

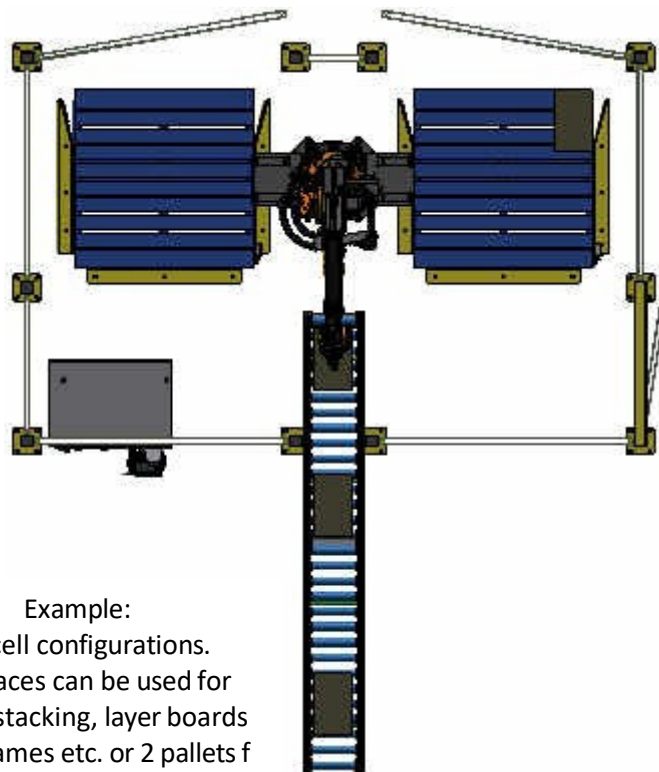

Example:
2 pallet cell configurations.
Pallet spaces can be used for
product stacking, layer boards
or top frames etc. or 2 pallets f
product stacking

Indicative Pricing (\$AUD)

- Single (1) pallet cell, utilizing Kuka KR20 robot or similar \$100,000 ~ \$125,000
- Two (2) pallet cell, utilizing Kuka KR20 robot or similar \$115,000 ~ \$145,000
- Four (4) pallet cell, utilizing Kuka KR120 robot Or similar \$130,000 ~ \$180,000

Note : Pricing will vary depending on operator interface , in feed configuration , EOAT - gripper design, if auto gripper changeover systems needed, etc.

E&O.E. Jan 2024