

CIGNO[®]

 **G. MONDINI**



CIGNO

NEW GENERATION COMPACT TRAY SEALER



FOR ALL YOUR PACKAGING NEEDS

SECURITY

EXPERIENCE

PERFORMANCE

FLEXIBILITY

FORMING

Platformer

Paperseal

Lining

Kirigami

Stacker

TRAY HANDLING

Denesting

Handling

PRODUCT HANDLING

Dosing

Integration

Loader

PRIMARY PACK

Tray sealer

Snap On Lid

SECONDARY PACK

Crate Loader

INTEGRATION

Neural

Valves

Detector

Labeling

Weight

COMPACT SOLUTION FOR AN OUTSTANDING RESULT

CIGNO is the latest development in the Mondini tray sealer range. An innovative compact design delivers a perfect solution for packaging operations across the food industry. Remarkably flexible, the CIGNO is capable to operate in all environments from Supermarket back store operations to in line factory-based production. Simplicity in design and construction delivers a tray sealer that is intuitive, productive, with hygienic design and with easy access for tool change, cleaning and maintenance.

FOR ALL TYPE OF PACKAGING SUPPORT



FORMING				TRAY HANDLING		PRODUCT HANDLING			PRIMARY PACK		SECONDARY PACK	INTEGRATION					
Platformer	Paperseal	Lining	Kirigami	Stacker	Denesting	Handling	Dosing	Integration	Loader	Tray sealer	Snap On Lid	Crate Loader	Neural	Valves	Detector	Labeling	Weight

FEATURES

- Pocket sized footprint.
- Single tool cavity.
- Simple and fast tooling change (2 minutes).
- **Single lane** to simplify operation and line management.
- Hygienic design and fully wash down.
- Open design for user friendliness and accessibility.
- Designed for stand alone or in line synchronized operations.

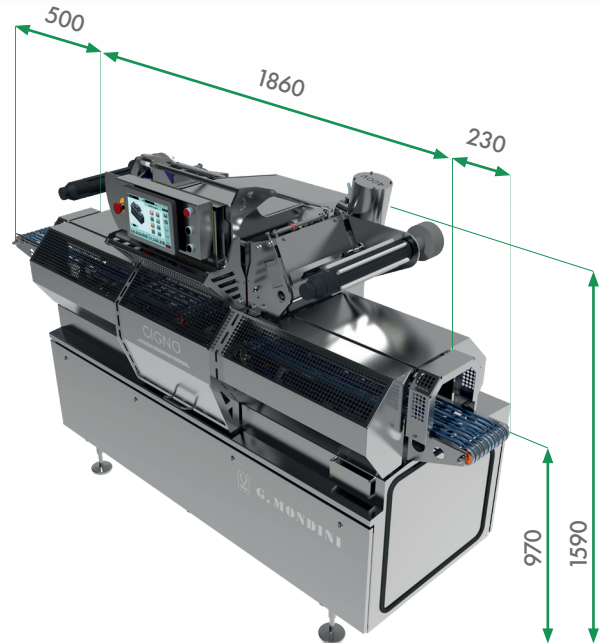

PRODUCTIVITY

Totally servo-driven to achieve:

- Gas flush: 25 cycles/min
- Skin: 15 cycles/min

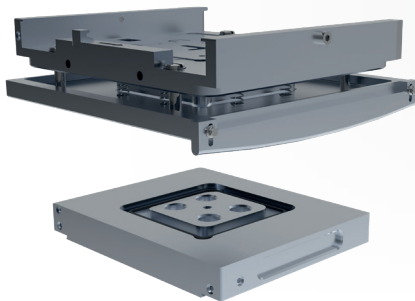

SEALING TOOL

Unique new tool design minimizes components and increases productivity making tooling change simple, intuitive and robust.



EASE OF USE

- CIGNO single lane operation automatically manages product, reducing labour.
- Easy operator training through Augmented Reality.
- Innovative "Goose neck" design for giving easy accessibility.

STANDARD G.MONDINI SEALING QUALITY

- Electro-mechanical lifting system to deliver perfect results every cycle.
- CIGNO delivers up to 600kg seal pressure for safe secure sealing on every tray.
- CIGNO can handle tray dimensions up to 260x190mm

CIGNO®



G.MONDINI S.p.A.
Via Brescia, 5/7 - 25033 Cologne (BS) Italy
tel. +39 030705600
www.gmondini.com - info@gmondini.com

All the contents of this document, including the texts, graphics and layout, belong to G.Mondini S.p.A. and cannot in any way be reproduced, published, distributed, transmitted and in any case used by any third party without written authorisation from G.Mondini S.p.A.