

# Electric automation

**FESTO**

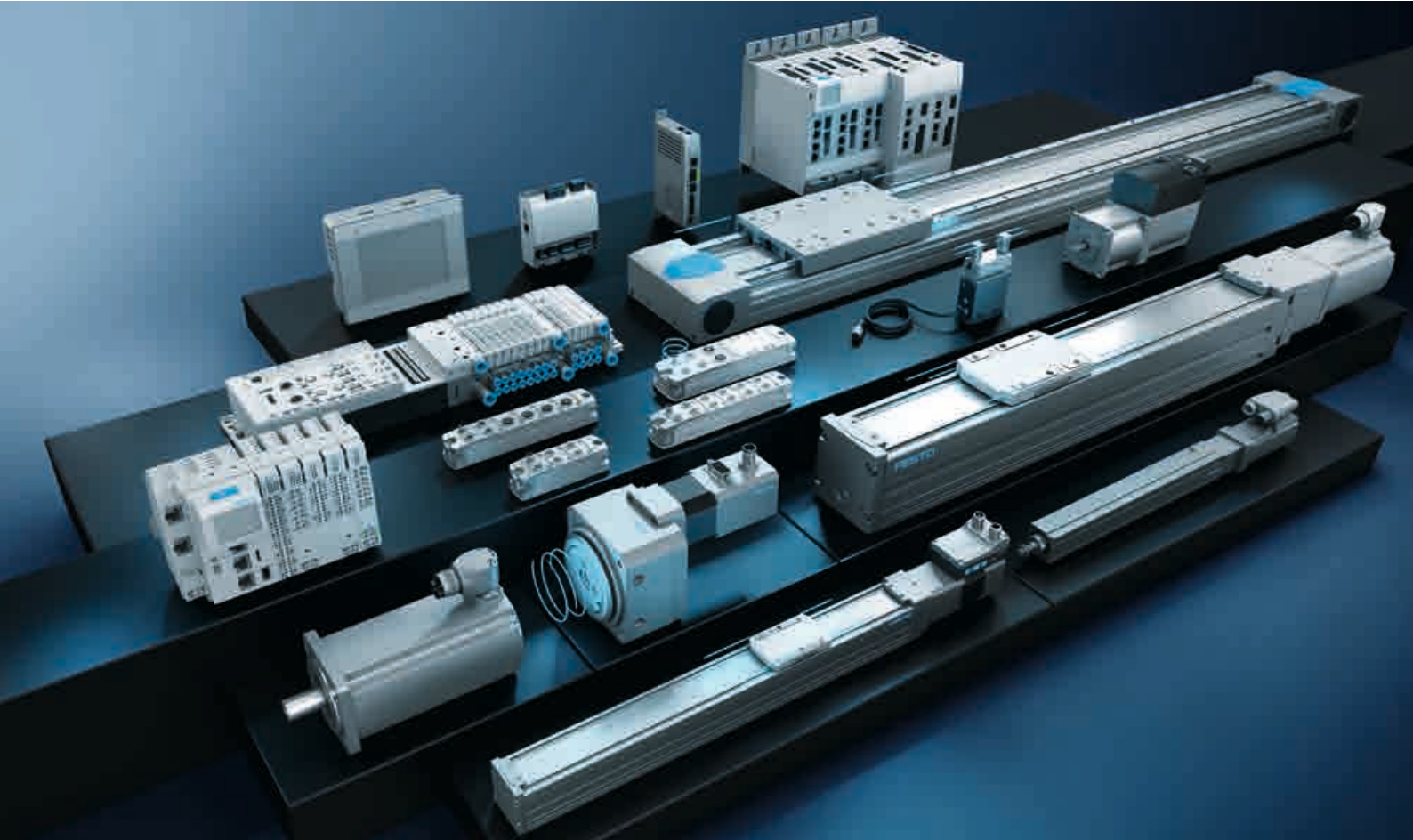

You want easy and seamless connectivity?  
You are looking for lasting and compatible concepts?  
We connect the present to the future.

→ WE ARE THE ENGINEERS  
OF PRODUCTIVITY.

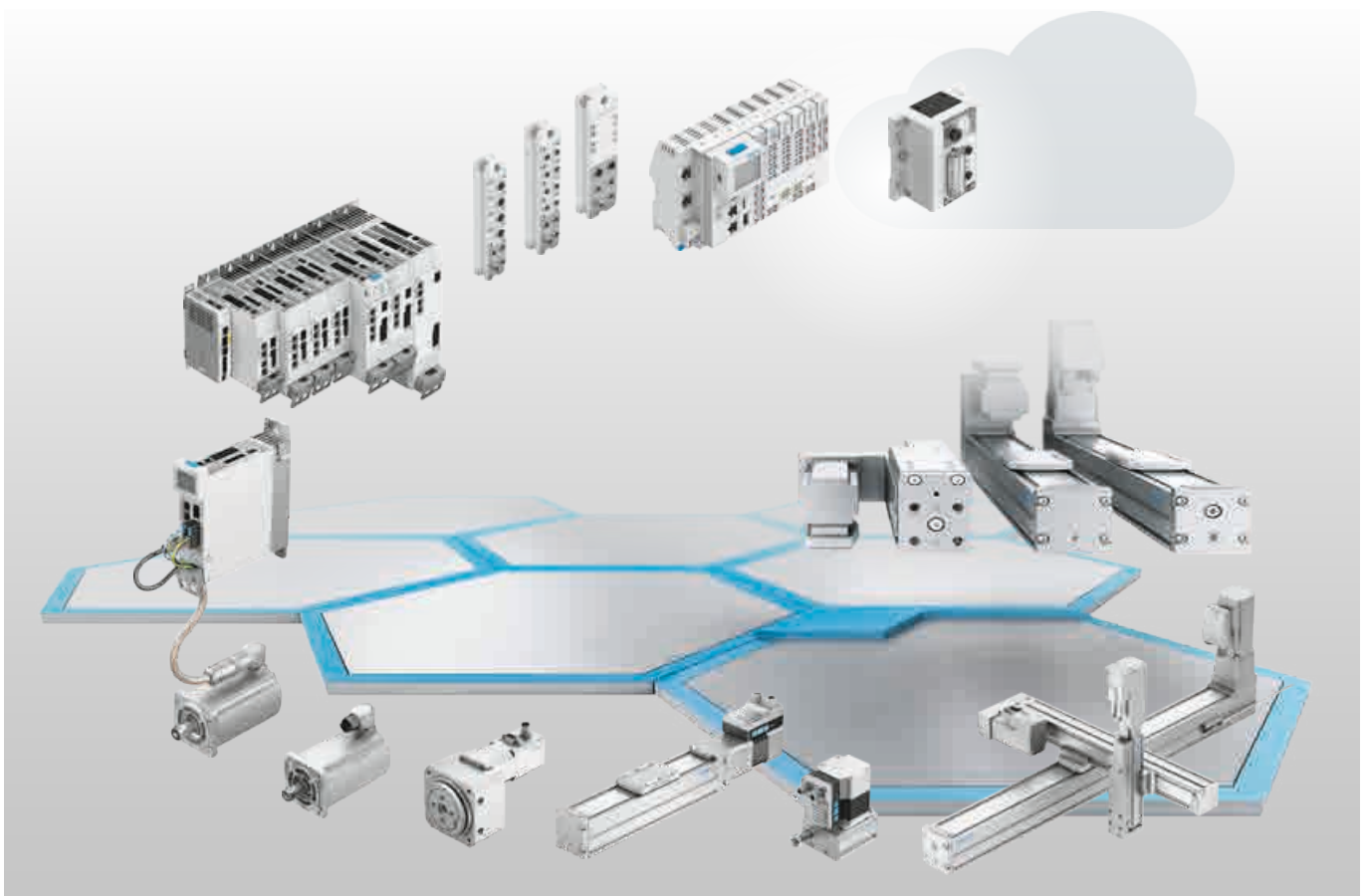

#### Page 4

#### Overview and Motion Series

- 4 Direct integration into host systems
- 6 Festo Automation Platform and EtherCAT®
- 8 From the controller to the mechanics
- 10 Product overview
- 12 Simplified Motion Series

#### Page 16

#### Axes, cylinders and mini slides

- 16 Spindle and toothed belt axes
- 23 Cantilever axes
- 25 Electric cylinders
- 28 Mini slides

#### Page 30

#### Grippers, rotary drives

- 30 Grippers
- 31 Stopper cylinders
- 32 Rotary drives

## Seamless connectivity is electric automation without any compromise

Put your trust in a partner who has been setting technological standards for decades, whether in pneumatic or electric automation. And don't expect anything less than a comprehensive offer of solutions, from mechanical systems, integrated motion control solutions and subsystems to modern cloud solutions for a variety of industries.

To pave the way for the seamless automation of machines and systems, Festo offers a unique range of solutions. We help you to connect your automation components and modules so that they interact perfectly at all times, mechanically, electrically and intelligently.

### **Mechanical connectivity**

The extensive portfolio of mechanical linear axes and rotary modules offers you almost infinite variety for automating motion, compatible with your in-house standard and of course with our servo motors.

### **Electrical connectivity**

Our range of servo motors and servo drives is the ideal link between your mechanical system and your control technology, always optimally coordinated and easily configured with our engineering software.

### **Intelligent connectivity**

The decentralised control of individual process modules, the free and flexible communication with other control devices and the integrated motion control solutions from Festo enable a wide variety of solutions for industrial automation tasks. They are all supported by innovative engineering and configuration software.

Seamless  
connectivity

from your  
workpiece to  
the cloud

### **Page 34**

#### **Servo drives, motors and integrated drives**

- 34 Servo drives
- 38 Servo motors
- 40 Stepper motors
- 41 Integrated drives

### **Page 42**

#### **Controllers, software and handling systems**

- 42 Decentralised remote I/O system
- 44 Multi-axis control systems
- 48 Functional safety
- 49 Software
- 52 Handling systems

## Seamless connectivity: direct integration into host systems

Whether for electric or pneumatic automation solutions, servo drives, integrated drives and remote I/O systems as well as valve terminals can be integrated directly and seamlessly into your system environment.

You can very quickly and easily define the mechatronic 1D, 2D or 3D kinematics and select the matching motor and servo drive or appropriate valve terminals, plus the necessary remote I/O system, since we support you every step of the way with

innovative software tools for configuration and selection. These solutions can then be directly integrated into larger or different automation environments using Ethernet-based protocols such as PROFINET, EtherNet/IP,

EtherCAT, Modbus, etc. In addition, Festo provides you with the function blocks you need to integrate the parameters into automation solutions from Siemens, Rockwell, Omron, Beckhoff and others.

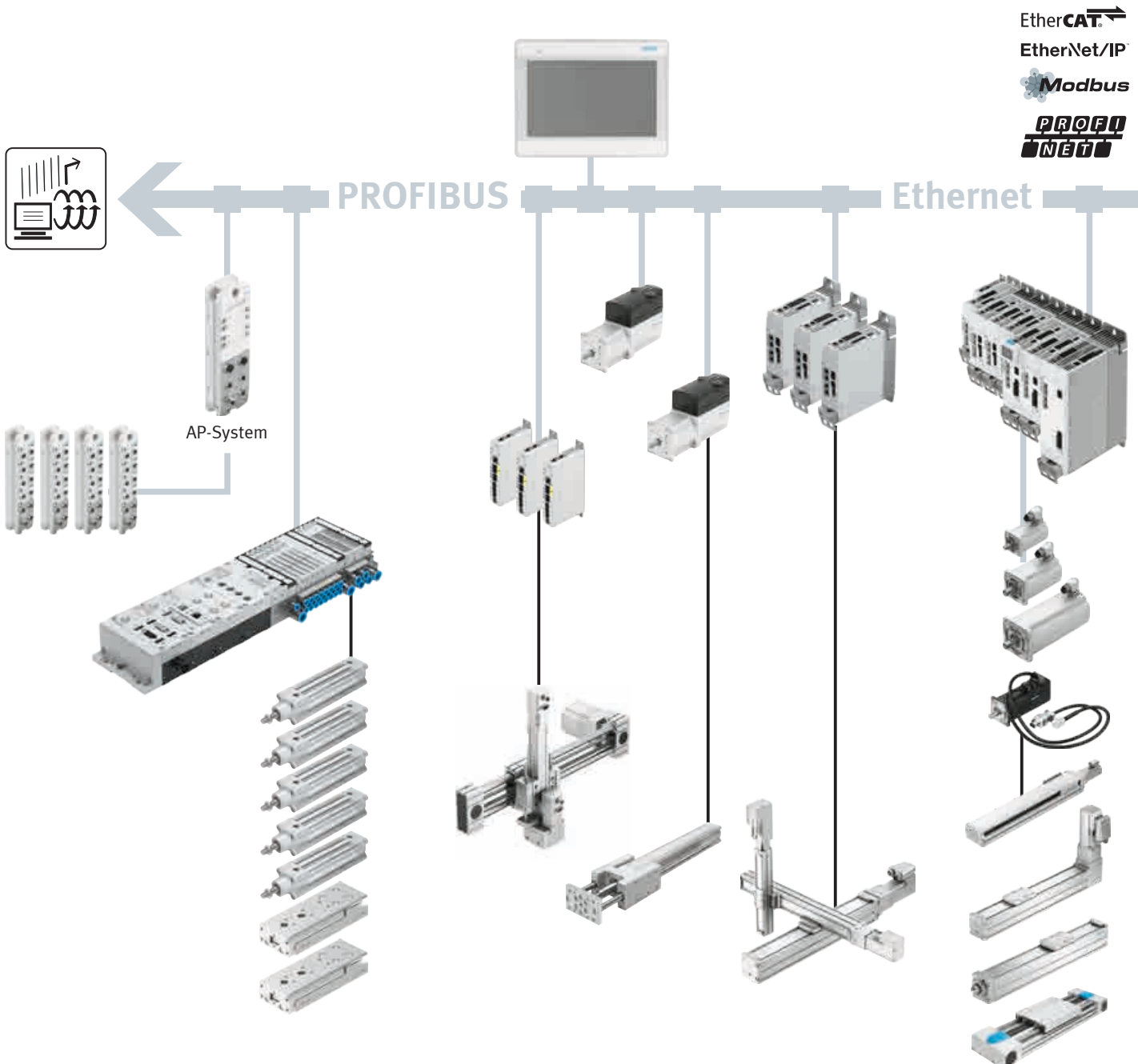



Connecting electric and pneumatic automation technology to Ethernet-based protocols using IO-Link® is even easier. The remote I/O solutions CPX-E and CPX-AP-I with their IO-Link® masters enable you to quickly

and easily connect a large number of automation components from Festo and third-party suppliers to a host PLC. As well as servo drives and grippers, valve terminals, proportional valves and sensors, you can also

directly integrate the products from the Simplified Motion Series. Further valve terminals and additional digital and analogue I/Os can also be connected to the network via the AP system communication

technology of the CPX-AP-I. The innovative and universal software solutions from Festo make it easy for you, and support you at every stage.

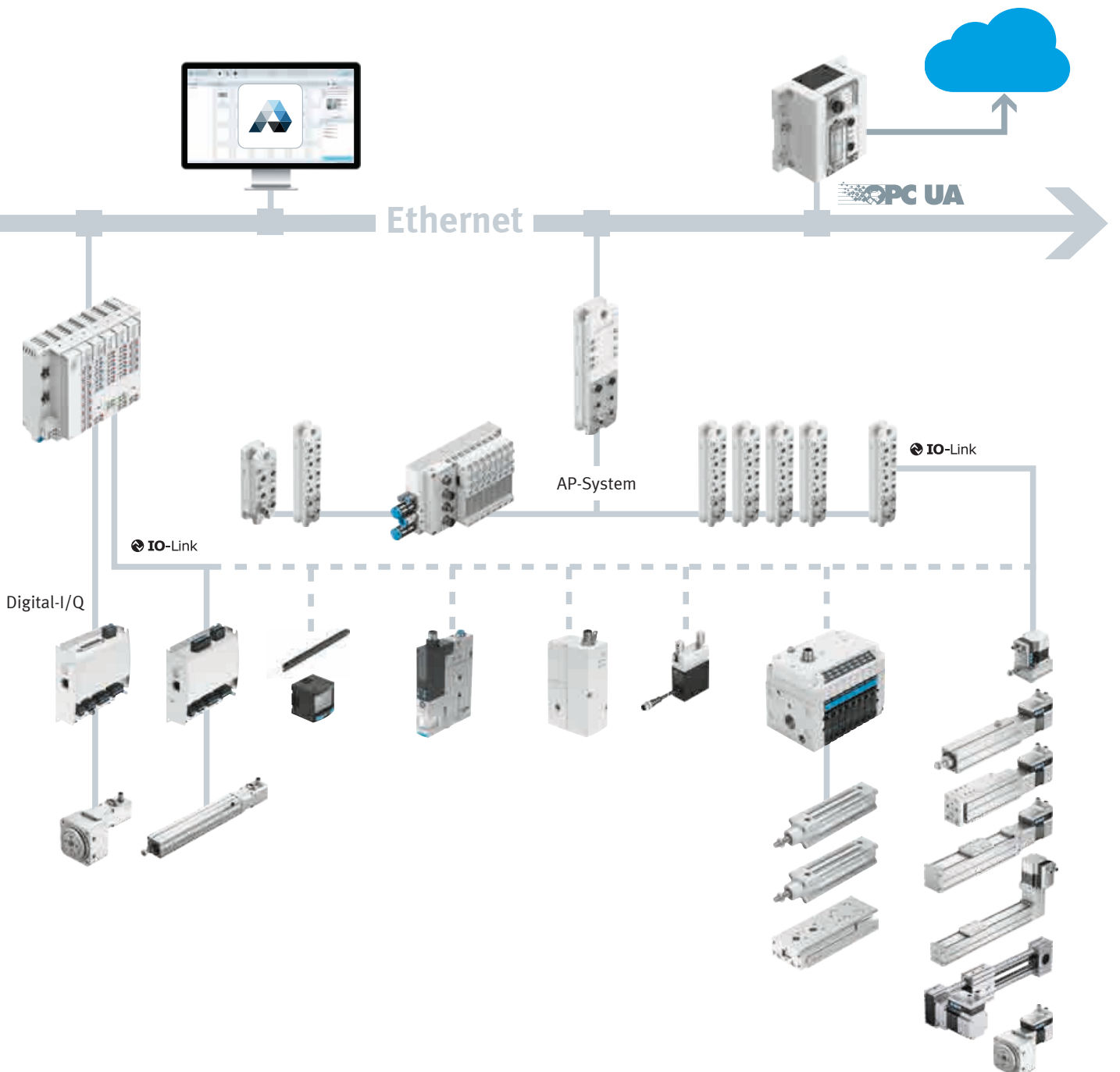

## Seamless connectivity: Festo Automation Platform and EtherCAT®

If you are looking for solutions for autonomous cells or sub-systems, or if you require powerful preprocessing, the new Festo EtherCAT® master controller CPX-E-CEC is perfect. You can integrate it as a subsystem into

larger or different automation environments by using Ethernet-based protocols such as Modbus®, PROFINET and EtherNet/IP.

With the interface OPC-UA, you can link CPX-E-CEC into Industry 4.0 host environments and cloud concepts. By using dashboards from Festo, you can also integrate the data from Festo components into Siemens MindSphere or Factory Talk from Rockwell's IoT environment.

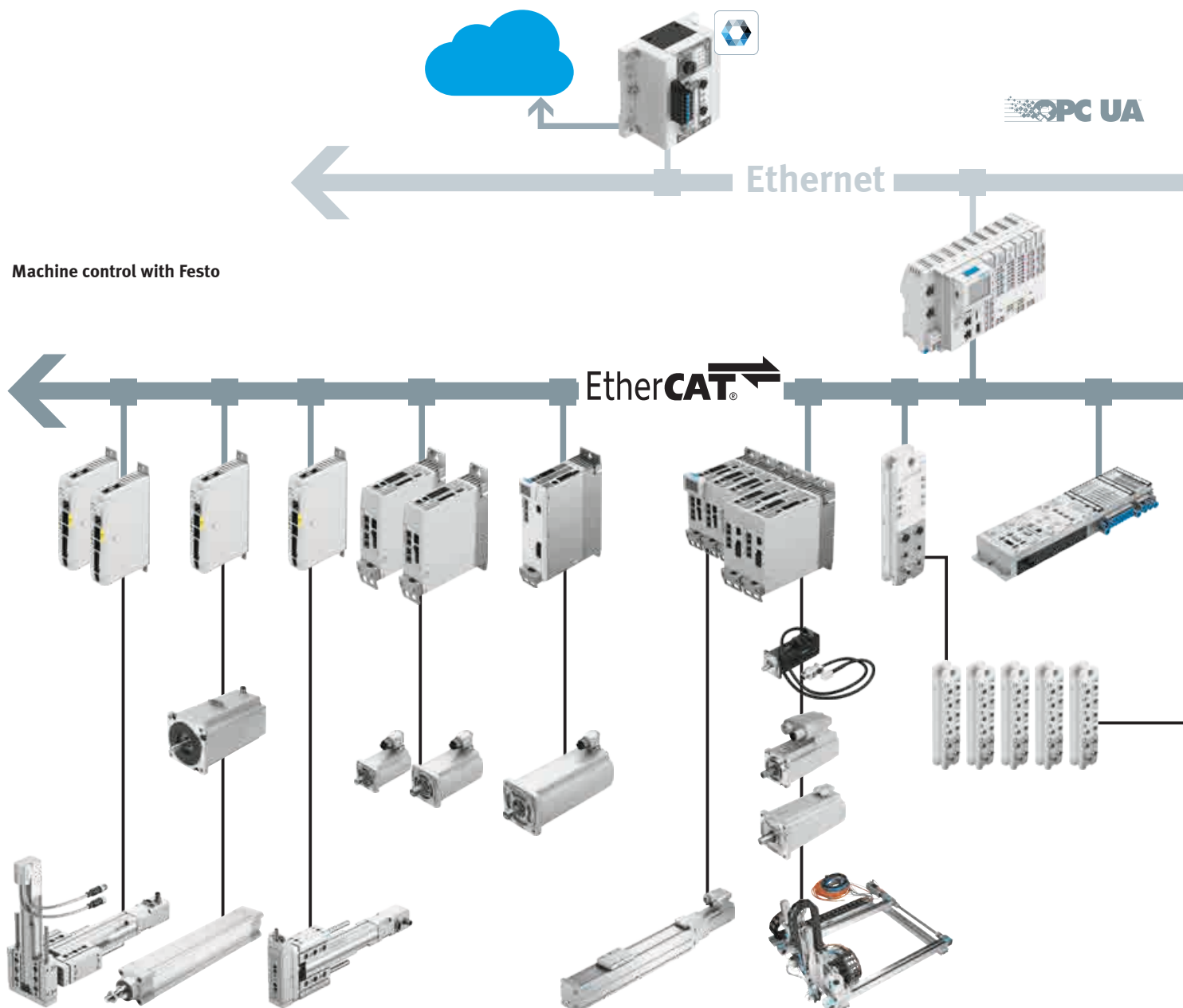

Machine control with Festo

With this approach, you can realise autonomous cells and subsystems and subsequently network them; or you can fully automate the powerful pre-processing of a mechatronic solution from Festo.

Integrated into the host system of an EtherNet/IP environment, e.g. from Rockwell, all drives can be interpolated!

And all the engineering advantages are at your disposal in subsystems, including fast mechatronic design as well as easy programming within the Festo Automation Platform.

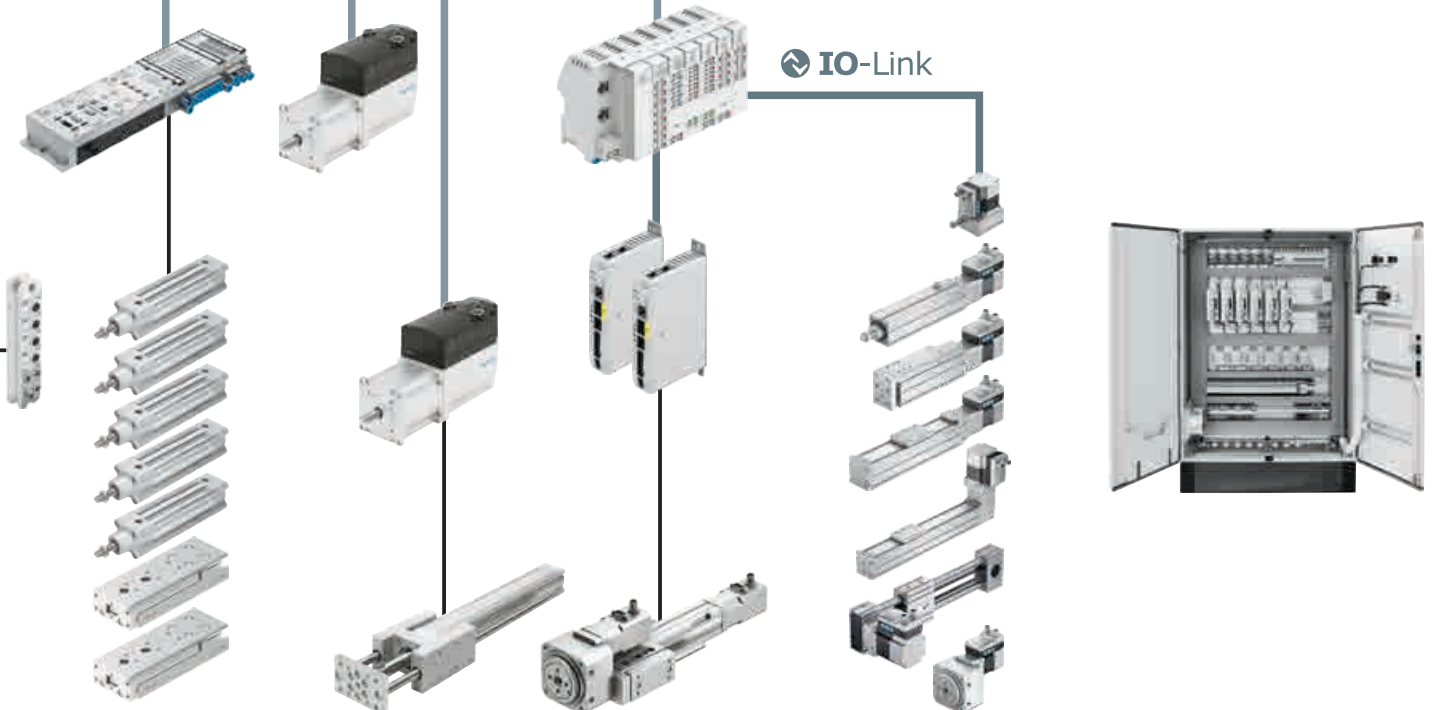

## Seamless connectivity – from the controller to the mechanics

### Easily integrated into your automation environment

Installation and control concepts influence each other. This means that architectures must be cleverly networked to achieve seamless connectivity. Hardware and software work together intelligently on the Festo Automation Platform – a perfect and seamless combination of controller, servo drive and mechanics. The wide range of mechanical systems offers a solution for virtually any motion requirement. And the Festo Automation Suite software ensures quick and perfect commissioning of all hardware components.

Festo offers a unique range of concepts for your drive solution.

Whether you're looking for

- a. an autonomous control concept for greater modularity and freedom in the system layout,
- b. perfectly networked control solutions with other standard control concepts, or
- c. perfect, seamless integration into your system environment with Ethernet-based protocols,

anything is possible.

### Control level

System diversity combined with seamless connectivity requires perfect interconnectedness between servo drives from different controller manufacturers and networks – with full functionality.

The controller CPX-E from Festo is suitable for small and medium-sized production systems or subsystems. The complete controller and motion control solution with EtherCAT® master controller is also suitable for

challenging tasks with real-time requirements. Autonomous, compact, modular – or to put it another way, stand-alone.

### Drive level

Optimally coordinated servo drive packages comprising motor and state-of-the-art servo drive connect the controller and mechanics.

The CMMT-AS is one of the most compact servo drives on the market for low-voltage drives, and is suitable for both point-to-point and interpolating movements. The low-voltage drive CMMT-ST is an extremely economical solution for positioning tasks and motion solutions with low power requirements up to 300 W.

What both have in common is that the servo drive and accompanying motors take just a few minutes to commission with the Festo Automation Suite.

System integration? Not a problem! You can integrate the servo drives CMMT-AS and CMMT-ST directly into the system environment of third-party suppliers. The CMMT will function just like the servo drive of the controller supplier. The identical behaviour means that no drive-specific expertise is required for the CMMT. The complete drive

system comprising servo drive, motor and mechanics is perfectly integrated.

You will need Ethernet-based protocols such as PROFINET, PROFIBUS, EtherNet/IP, EtherCAT® or Modbus® as a prerequisite. Function blocks for several manufacturers such as Festo, Siemens, Rockwell, Beckhoff and Omron are available.

### Mechanical system at field level

Festo offers one of the broadest product portfolios for linear and rotary mechanical systems. In addition to rotary and linear drives, it includes precise spindle

axes and dynamic toothed belt axes with a stroke of up to 8.5 m, highly precise mini slides with accuracy of up to 15 µm, powerful electric cylinders as well as rigid and dynamic cantilever axes.

The right mechanics for almost every application, up to variants to IP65 or with FDA-compliant materials.

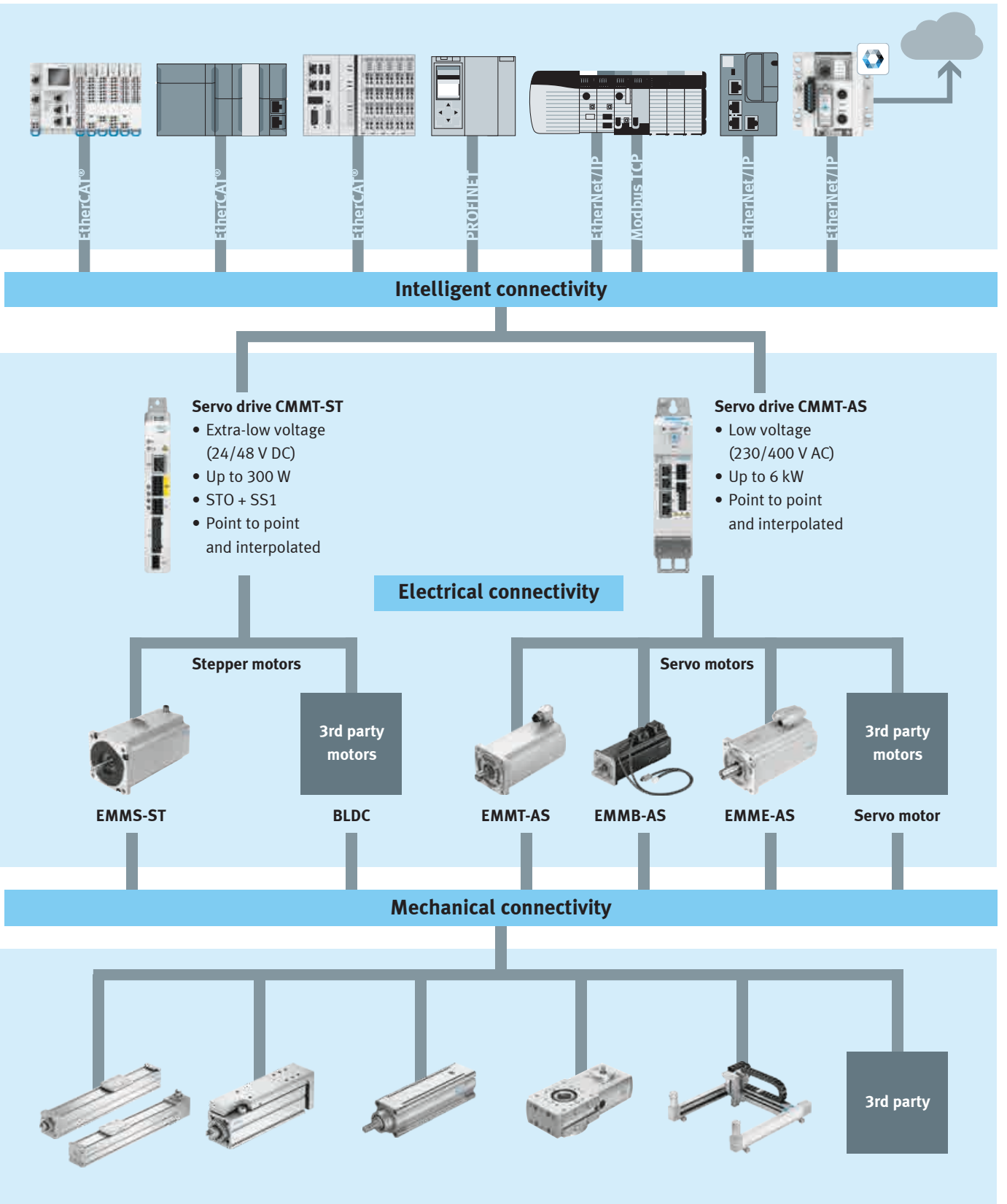



# Electric automation – product overview

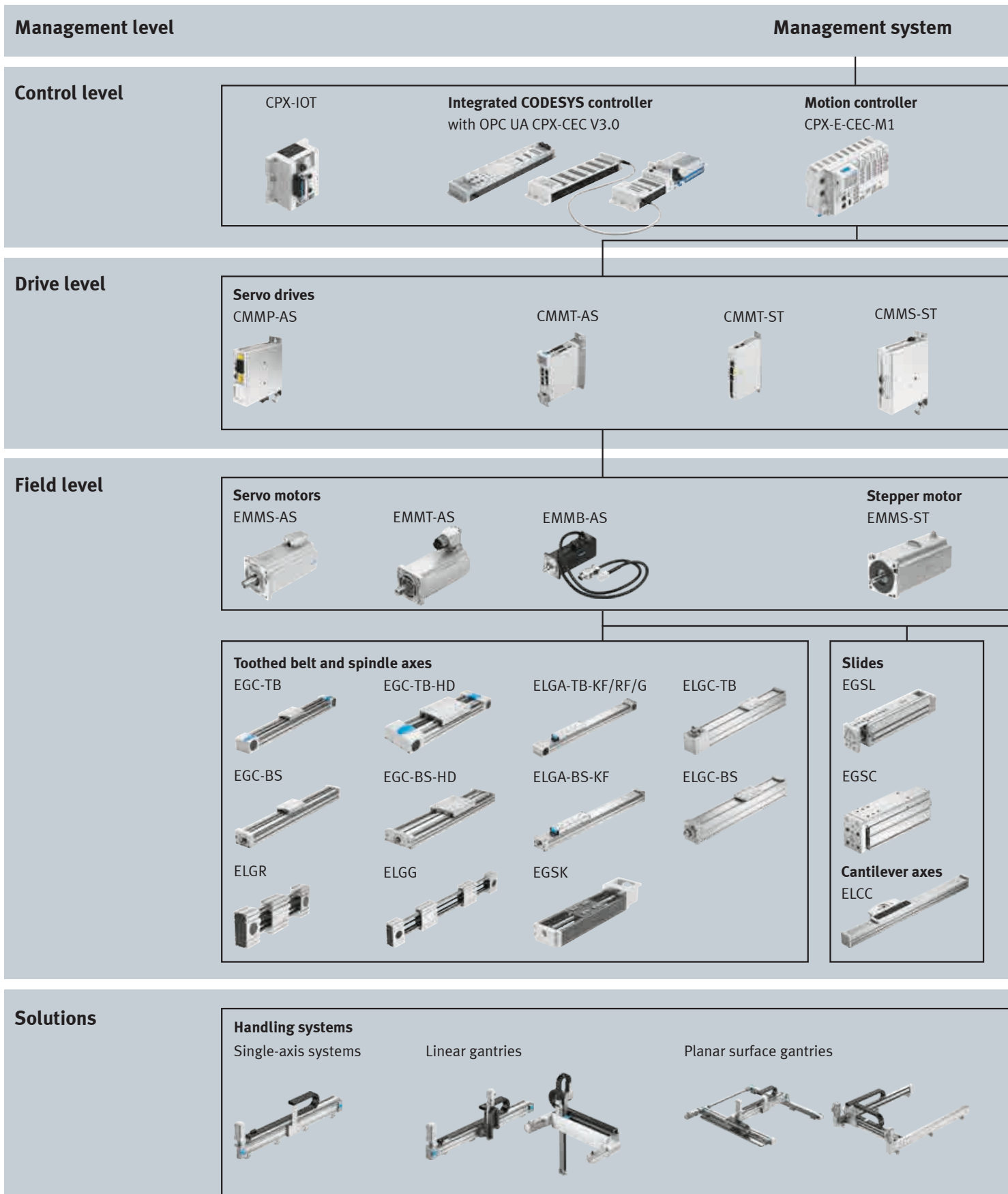

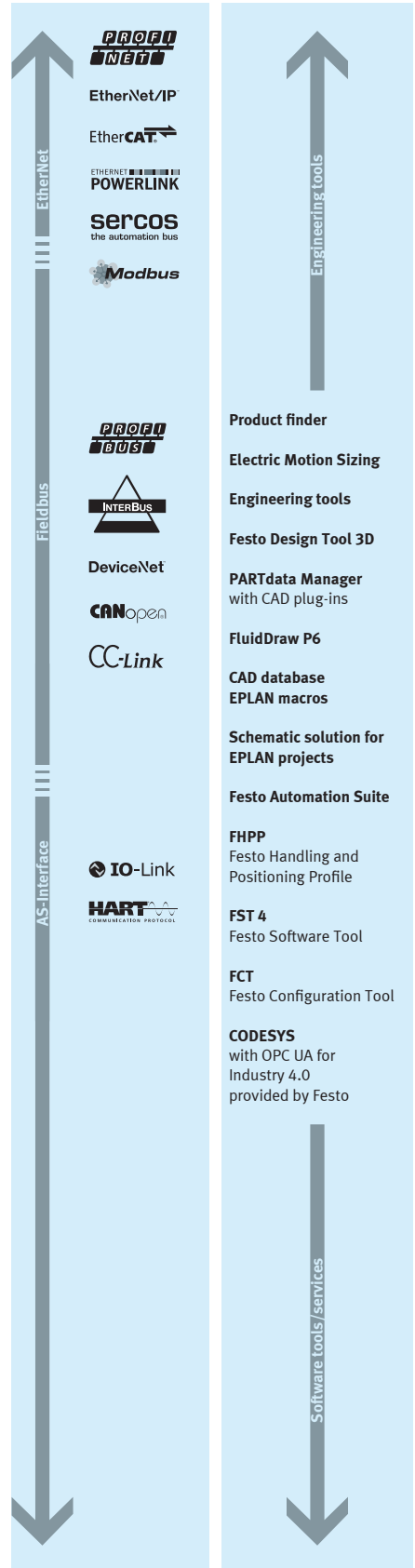
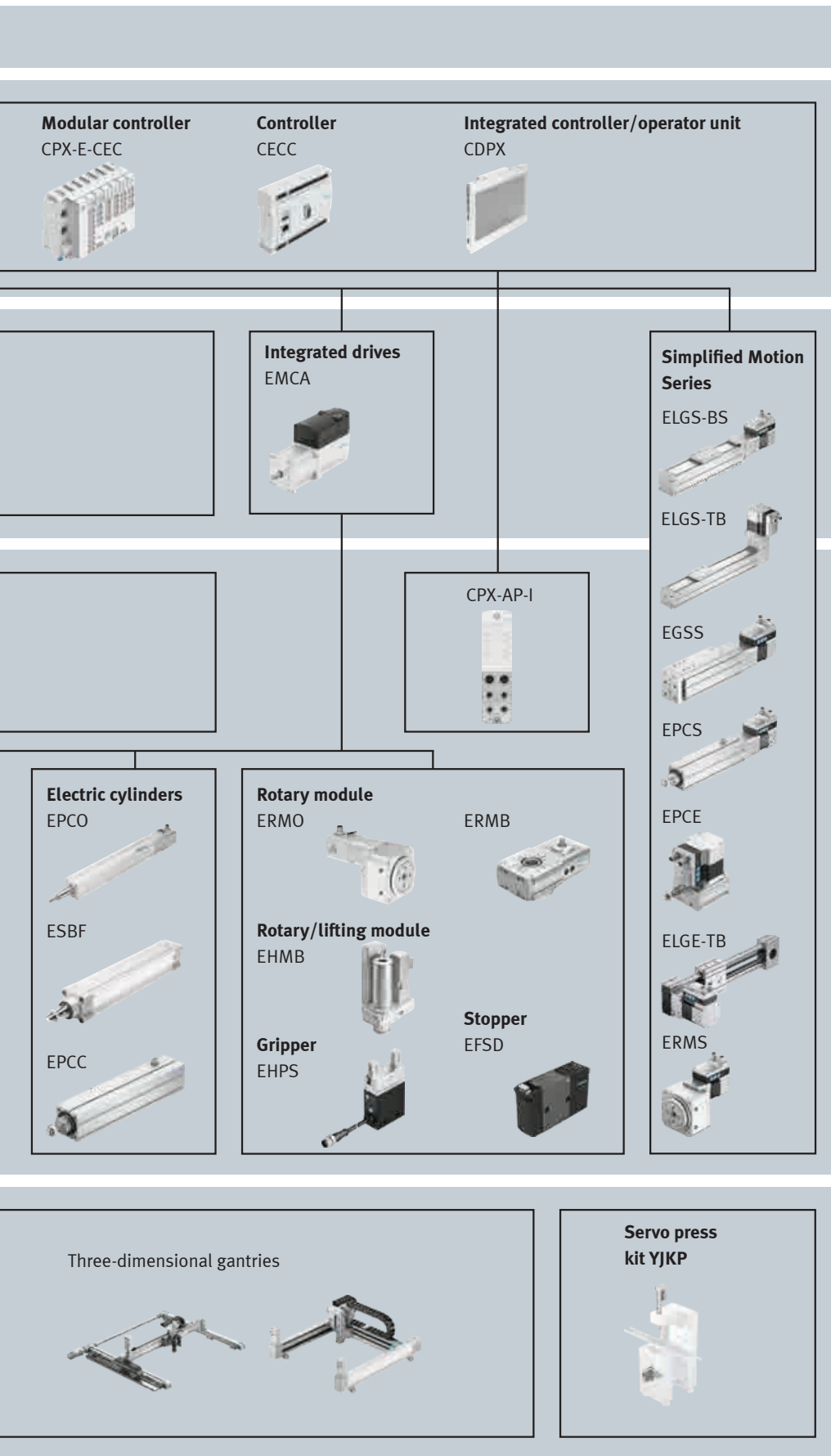

## Simplified Motion Series

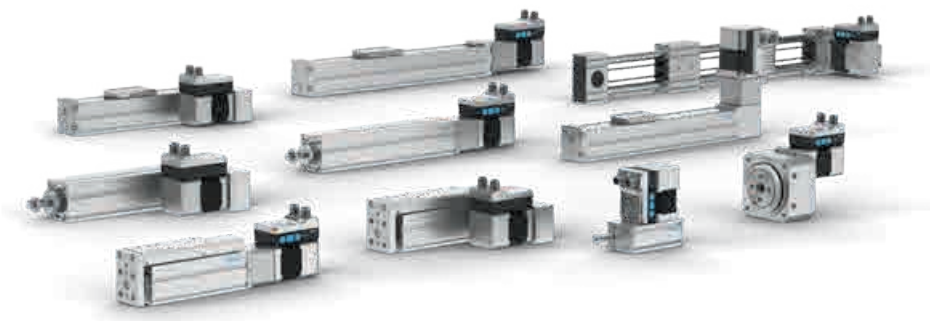

The Simplified Motion Series consists of different electro-mechanical components together with a simple and application-optimised combination of motor and servo drive, the so-called integrated drive. This solution therefore requires no external servo drives, because all the necessary electronic components are already integrated and optimised for simple movements between two end positions, including intermediate position.

Special motion characteristics can be set and adjusted, such as gently cushioned retracting into the end position, or a simplified press-fitting and clamping function. This electrical alternative doesn't require the usual, often complex commissioning processes of traditional electric drive systems to achieve very simple linear and rotary motion and positioning tasks.

Commissioning is quick and easy without the need for any software, computers or other accessories, because all parameters can be manually adjusted directly on the drive. Simplified Motion Series is directly connected to the controller, either via digital I/O (DIO) or IO-Link®, both of which are integrated as standard. A control cabinet is not required for installation, since the drives are mounted directly into the machine.

## IO-Link

Powerful point-to-point communication is also integrated via IO-Link® for intelligent connection with the controller and all the way to the cloud.

Extended range of functions with IO-Link®:

- Motion parameters can be adjusted remotely
- Copy and backup function for transferring parameters between the drive and computer, or from the computer to another identical drive
- Read functions of the process parameters
- Updating the firmware of all new Simplified Motion Series products or those that are already installed can now be done via IO-Link®.



- 1** During commissioning, all relevant parameters can be simply and intuitively adjusted directly on the integrated drive.
- Speed out: speed for the movement away from the reference end position
  - Speed in: speed for the movement to the reference end position

- Force: force of the drive in the "advanced" position
- Reference: setting the reference end position of the drive
- Start press: setting the position at which the power-controlled movement begins
- Demo: manual start (similar to manual override)

- 2** Simple electrical connection via M12 connector technology
- Power (4-pin): power supply for the motor
  - Logic (8-pin): control signal, sensor signal and current for the integrated electronics

## Simplified Motion Series – Overview of motion profiles

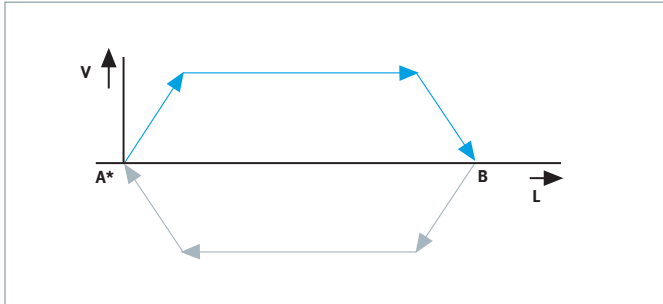

Basic profile for movement between two end positions:  
speed control without intermediate position

- End position B: freely adjustable
- Speed for "Out" and "In" movement: freely adjustable
- Position is maintained after end position B reached

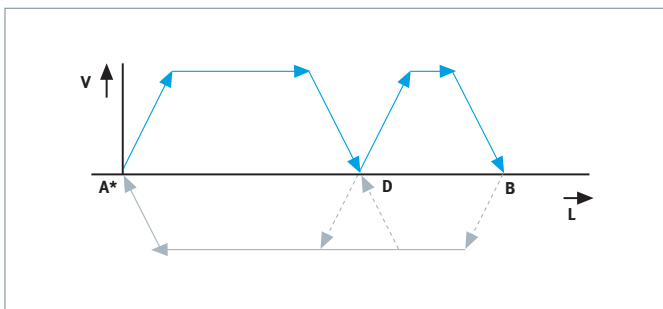

Basic profile for movement between two end positions:  
speed control with intermediate position

- End position B and intermediate position D (movement "Out"): freely adjustable
- Intermediate position for the "In" movement: can be used optionally and is freely adjustable
- Speed for "Out" and "In" movement: freely adjustable

Movement option pre-holding position:

- Same intermediate position D (pre-holding position) for "Out" and "In" movement
- Working motion between D (pre-holding position) and B (operating position)
- Rest position, e.g., during machine standstill in position A

Note: Intermediate position D can only be used with IO-Link®

**Note on extended use:** The drive can also be used for very simple positioning tasks by changing the intermediate position several times.

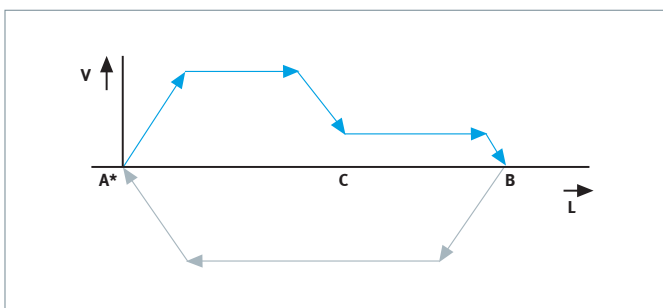

Extended motion profile for simplified press-fitting and clamping functions: with speed and force control

- End position B and begin of "force-controlled motion" C: freely adjustable
- - Force of movement from C to B: freely adjustable
- - Speed for "Out" (until point C) and "In" movement: freely adjustable

- "Out" movement
- "In" movement
- A\* Reference end position
- B Operating position
- C Start position "press"
- D Intermediate position

## Overview of the Simplified Motion Series

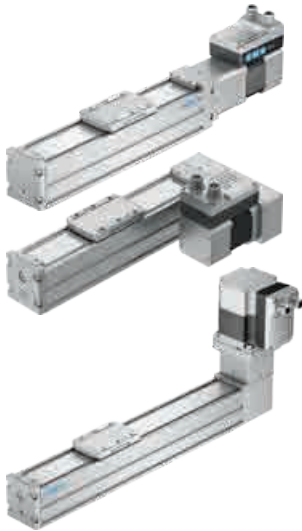

### Spindle axis ELGS-BS

Extremely compact and cost-effective spindle axis with precise, resilient recirculating ball bearing guide for the slide and powerful ball screw drive.

- Three sizes for a payload of up to 20 kg at a max. stroke of 800 mm
- Choice of axial or parallel motor mounting
- Variety of cable outlet directions and motor positions – can be changed at any time

### Toothed belt axis ELGS-TB

Compact and extremely cost-effective toothed belt axis with precise, resilient recirculating ball bearing guide for the slide, and durable belt.

- Two sizes for up to 1.3 m/s at a max. stroke of 2,000 mm

### Common features

- Permanent stainless steel cover strip protects the internal guide and spindle or toothed belt
- Unique "one-size-down" assembly system
- Optional: vacuum connection to minimise particulate emissions from the axis into the system



### Mini slide EGSS

The powerful and resilient EGSS with smooth-running spindle is the precise solution for guided linear individual movements or vertical Z movements.

Three sizes with a max. stroke of 200 mm at a repetition accuracy of  $\pm 20 \mu\text{m}$

- The internal guide absorbs transverse loads and provides very good resistance to torsion at high torques
- Direct mounting of the ERMS without the need for adapters



- Optional ducted compressed air compensation prevents particles or moisture from entering, and particles from escaping into the environment
- Choice of axial or parallel motor mounting
- Variety of cable outlet directions and motor positions – can be changed at any time



### Electric cylinder EPCS

The EPCS with smooth-running ball screw is ideal for linear individual movements. As an extremely cost-effective complete solution, the electric cylinder is perfect for applications such as clamping, distributing, sorting and ejecting, and in handling systems as a simple Z-axis.

- Three sizes with a max. stroke of 500 mm and 0.36 m/s
- Simple and cost-effective position sensing with proximity switch



- Optional ducted compressed air compensation prevents particles or moisture from entering, and particles from escaping into the environment
- Choice of axial or parallel motor mounting
- Variety of cable outlet directions and motor positions – can be changed at any time





### Electric cylinder EPCE

The EPCE is an electric cylinder for short strokes and cycle times, offering a minimal zero stroke and excellent value for money. It is ideal for use in testing and inspection systems as well as for labelling, in simple centring tasks and for aligning workpieces.

- Optimised product design for maximum component density
- Minimum stroke 5 mm, up to a maximum stroke of 80 mm
- Piston rod variants: one or two, at one or both ends
- Optimised mounting options and flexible cable outlet (4x90°)



### Toothed belt axis ELGE-TB

The attractively priced toothed belt axis with recirculating ball bearing guide ensures very good, smooth-running behaviour; it is ideal as an economical solution for very simple tasks with comparatively low requirements

for mechanical load, dynamic response and precision, as well as for the environment.

- High running performance of 5,000 km



### Rotary drive ERMS

The rotary drive for simple swivelling tasks or for increased mechanical loads has sturdy, precise and backlash-free ball bearings for the rotary plate, thus absorbing transverse loads and torques.

- Two sizes, each with a swivel angle of 90° and 180°
- Sealed hollow shaft for the integrated through-feed of cables or tubing



### Solution Finder

For configuring simple movements. Configure, select and order – in no time at all.

## Spindle axis and toothed belt axis ELGC



The spindle and toothed belt axes ELGC stand out thanks to their internal, recirculating ball bearing guide protected by a permanent stainless steel cover strip. They both have their clean look, weight-optimised design and flexibly mounted motor in common.

The spindle axes ELGC-BS promise precise and smooth running, whether installed horizontally or vertically. The toothed belt axes ELGC-TB are designed for higher acceleration and speed, while maintaining good rigidity and load bearing capacity.

The unique and universal "one-size down" assembly system with mounting elements for axis/axis assembly enables direct mounting without an additional adapter plate. Thanks to the matching interfaces, the axes are suitable for XY movements and vertical Z movements.



### Vacuum connection

- Standard: sealed connection for leak-proof axis
- Optional: can be upgraded with vacuum connection later if required
- With vacuum connection: increased protection of the system thanks to lower particle emissions

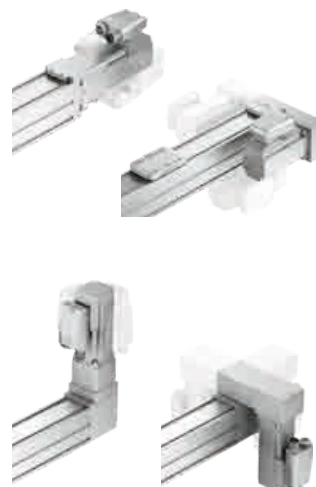

### Flexible motor mounting

- Free choice of motor positions and mounting kits, can also be changed at a later date:
- Axial kit: 4 x 90° motor position
- Parallel kit: mounting direction rotated 3 x 90° and motor position rotated 3 x 90°

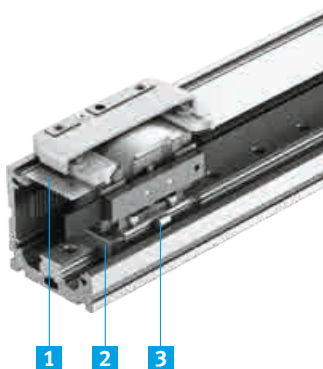

### 1 Stainless steel cover band

- To protect the interior guide and toothed belt
- Tight seal thanks to magnetic strips
- No sagging with inverted installation

### 2 Recirculating ball bearing guide

- Integrated recirculating ball bearing guide with long service life
- Rigid precision guide rail to absorb high guide forces

### 3 Magnet for position sensing

- Position magnet on both sides of the slide
- Standard with spindle and toothed belt axes
- For simple, low-cost position sensing together with proximity switch SMT-8M

**Unique "one-size-down" assembly system**

Linear or three-dimensional gantries, pick & place solutions or 3D cantilever systems are easy to combine and assemble without the need for any special expertise or tools.

- Adapterless connection of axes and mini slides for compact handling systems
- Base axis combined with next smallest mounting axis without any additional adapter plate using the universal profile mounting

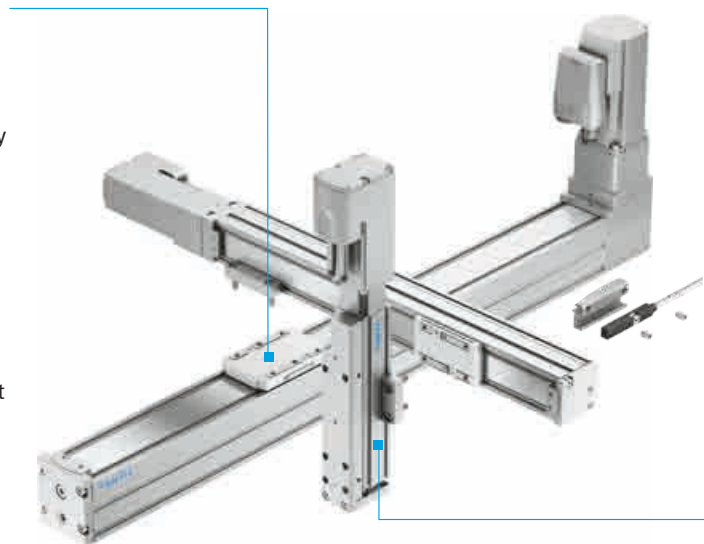

**Cost-effective position sensing**

- Magneto-resistive proximity sensor SMT-8M as normally open or normally closed contact with switching output PNP
- Can be fitted quickly, flexibly and securely in the profile with the sensor bracket and is easy to insert flush into the bracket from above
- Can be extended or repositioned at any time

**Mini slide EGSC-BS**

→ See page 29



**Linear gantry**

Vertical 2D movements for simple handling tasks – low cost, space-optimised and easy to assemble



**Cantilever system**

Simple compact handling system for simple 3D movements – adapter-free, cost-optimised system design with long Z stroke



**Cantilever system**

Installation-space optimised, robust 3D handling unit for higher loads – additional 90° adapter for more rigidity at higher loads



**Cantilever system**

Compact and cost-effective 3D system with longer Y stroke; the two axes are mounted in parallel, including driveless guide axis ELFC, to absorb increased torque and provide improved guidance

Configure your handling system quickly and easily with the Handling Guide Online. Find out more on pages 52/53

Type	ELGC-BS	ELGC-TB
Size	32/45/60/80	45/60/80
Drive	Spindle drive (ball screw)	Toothed belt drive
Max. stroke [mm]	1000	2000
Max. speed [m/s]	1	1.5
Max. feed force [N]	350	250
Repetition accuracy [mm]	±0.015	±0.1

## Toothed belt axis and spindle axis ELGA



The complete ELGA family with a protected guide in different variants is available with toothed belt or spindle drives, both as an individual axis or a complete solution in standard handling systems.

The toothed belt axes ELGA-TB have a high dynamic response and are designed for high speeds. The spindle axes ELGA-BS promise precise and smooth running. Both can cope with heavy loads and long strokes.

The internal slide guide, the stainless steel cover band, its virtually gap-free design and guide pulley in the slide provide perfect protection on the outside and inside, even in cleanrooms.

### An overview of guide variants

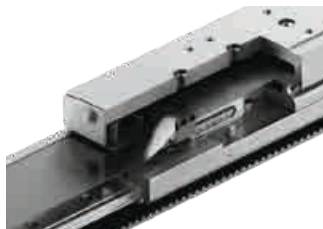

Recirculating ball bearing guide ELGA-TB-KF



Roller bearing guide ELGA-TB-RF



Plain-bearing guide ELGA-TB-G

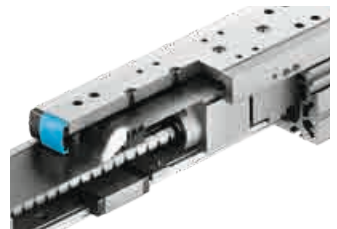

Recirculating ball bearing guide ELGA-BS-KF

### Toothed belt axis ELGA-TB-..

- Recirculating ball bearing guide -KF for absorbing high loads from slides and guides with lateral forces and torques, even during motion.
- Roller guide for highly dynamic handling, even of medium-sized and large work pieces.

- Plain-bearing guide -G for simple positioning and handling tasks or as a drive axis for applications with an external guide.

### Spindle axis ELGA-BS-..

- Recirculating ball bearing guide -KF for absorbing high lateral forces and torques, even during motion.

### Motor positions



#### Toothed belt axis ELGA-TB

- Motor position freely selectable on 4 sides
- Plug connection rotated 4 x 90°, can be modified at any time
- Position can be changed later at any time



#### Spindle axis ELGA-BS

- Motor position freely selectable at both ends
- Plug connection can be rotated 4 x 90°
- Can be rotated at any time

**Other variants:**

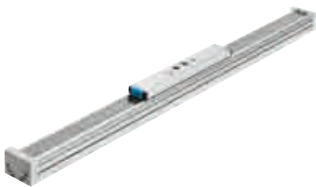

**Guide axis ELFA**

- Without its own drive
- Freely movable, passive slide
- Guide variants:
  - Roller bearing guide -RF
  - Recirculating ball bearing guide -KF

**Axis for use in the food industry**

- Clean look: smooth surfaces, no sensor slots
- ELGA...-F1 with FDA-compliant materials
- Guide variants:
  - Roller bearing guide -RF
  - Recirculating ball bearing guide -KF

**Second slide**

- For ELGA-TB-KF
- 1 driven and 1 freely movable slide
- For absorbing higher torques and loads
- Extended service life thanks to reduced, split guide loads

**Vacuum or sealing air**

- Greater protection thanks to an optional connection for vacuum or sealing air
- When used in cleanrooms: with vacuum, no particles from the axis can get into the environment
- When used in dusty or polluted environments: with sealing air, no dust or other environmental contaminants can get into the axis

**Focus on safety**



**Optional sensing for greater reliability**

- Inductive proximity sensor, freely positionable
- Degree of protection of the sensors: IP67
- Flush mounting in the profile slot
- Securing mounting in a clean design sensor bracket (plastic), easy to clean



**Displacement encoder for monitoring the linear axis**

- Suitable for safety-orientated applications (second channel)
- Linear measuring system for direct monitoring of the axis slide position
- Minimum resolution: 2.5 µm at a maximum 4 m/s

Type	ELGA-TB-KF				ELGA-TB-RF			ELGA-TB-G			ELGA-BS-KF			
	70	80	120	150	70	80	120	70	80	120	70	80	120	150
Size (= profile width in mm)	70	80	120	150	70	80	120	70	80	120	70	80	120	150
Drive system	Toothed belt										Ball screw spindle			
Guide type (slide)	Recirculating ball bearing guide				Roller bearing guide			Plain-bearing guide			Recirculating ball bearing guide			
Max. stroke [mm]	8500				7400			8500			2900			
Max. speed [m/s]	5				10			5			0.5	1	1.5	2
Repetition accuracy [µm]	±80				±80			±80			±20			
Max. feed force Fz [N]	350	800	1300	2000	350	800	1300	350	800	1300	300	600	1300	3000



## Toothed belt axis and spindle axis EGC and EGC-HD



Comprehensive range with numerous variants, e.g. for high dynamic response and speed, heavy loads and high torque. All in all, this range of heavy-duty axes from the mechatronic multi-axis modular system is suitable for stand-alone as well as complete system solutions.

The generously sized profiles of the EGC with their optimised cross-sections provide the drives with maximum rigidity and load capacity. Their speed, acceleration and torque resistance set a new standard, even with the new EGC-HD with heavy-duty guide for extremely high

loads and torque resistance at high speeds and acceleration.

An additional advantage is the high performance of the axes, which often makes it possible to choose a smaller design, especially in the case of spindle axes!

### The individual versions



**Toothed belt axis EGC-(HD)-TB**  
Dynamic drive for high speeds together with heavy loads and long strokes.



**Spindle axis EGC-(HD)-BS**  
Precision drive for accurate and smooth running together with high loads and long strokes.



**Guide axis EGC-FA**  
Driveless linear guide unit for supporting forces and torques in multi-axis applications.

### Heavy-duty variants HD



Toothed belt axis EGC-HD-TB



Spindle axis EGC-HD-BS

### Flexible motor mounting for EGC-(HD)-TB



- Motor position freely selectable on 4 sides
- Position can be changed later at any time

### The benefits to you:

Define an attachment variant with one part number as standard and modify the positions as and when needed.

## Different slide variants



### Second slide

- For greater axial and lateral torques
- Freely movable



### Extended slide

- Longer guide
- For greater axial torque

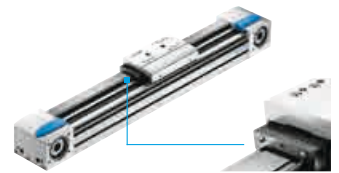

### Protected slide

- Scrapers on both sides of the slide remove dirt particles and liquids from the external guide

## Focus on safety



### Optional sensing for greater reliability

- Inductive proximity sensor SIES-8 M
- Flush mounting of up to two sensors per profile slot



### Additional inductive displacement encoder EGC-...-M

- Increased absolute accuracy, minimum resolution 2.5  $\mu\text{m}$
- Suitable for safety-orientated applications (second channel)
- Inherent system inaccuracies can be easily adjusted



### Clamping unit EGC-...-HPN for clamping the slide

- For safety-orientated applications
- Solutions of categories 1, 2 and 3 to EN 13849-1 can be implemented with 1 and 2 channel versions

Type	EGC-TB/BS-KF	EGC-HD-TB/BS
Size	50/70/80/120/185	125/160/220
Drive	Toothed belt drive/spindle drive	Toothed belt drive/spindle drive
Max. stroke [mm]	5000/8500 (10 000)	5000/2400
Max. speed [m/s]	2/5	5/1.5
Repetition accuracy [mm]	$\pm 0.08 \dots 0.02$	$\pm 0.08 \dots 0.02$
Max. force $F_x$ [N]	2500/3000	1500/1300
Max. torque load $M_x$ [Nm]	529	900
Max. torque load $M_y/M_z$ [Nm]	1820	1450
Options:	Connecting module for central lubrication	Connecting module for central lubrication

## Spindle axis ELGT

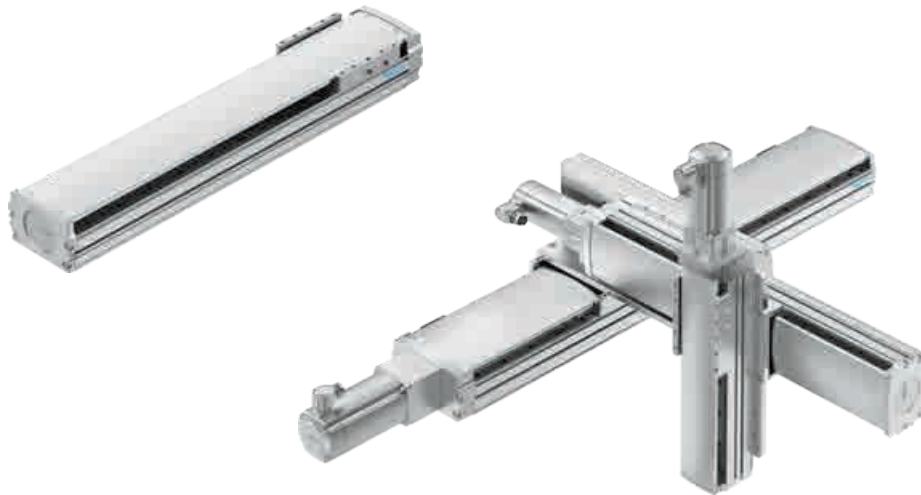

The compact and low-cost spindle axes ELGT with integrated double guide are perfect for combining into 2D and 3D cantilever systems. They have been developed for a wide range of applications, whether in the electronics industry, desktop applications or battery manufacturing, and they can be easily combined with axes ELGC and mini slide EGSC. Or they can be used in test and inspection systems, in small parts handling or in assembly systems.

### Sophisticated technology for outstanding performance

The high load carrying capacity and rigidity provided by the integrated double guide and the extremely sturdy connectors make the ELGT ideal for high payloads and strokes of up to 1,400 mm. For example, as a 3D cantilever system it can transport up to 20 kg at speeds of up to 0.5 m/s. A copper and zinc content of less than 1% means it can also be used in battery manufacturing.

### Economical in combination – versatile in use

The ELGT becomes even more economical when combined with the axes ELGC or the mini slide EGSC as a Z-axis for vertical movements. Suitable adapter kits for all Festo servo motors and many Asian and European motor providers as well as the adapter kit for opto-electrical sensors commonly found on the market in Asia, for example from Omron, make installation easy. Position sensing is cost-effective and easy using inductive proximity sensors.



Free choice of motor positions (turned 4x90°), can also be changed at a later date

Technical data	Size 90	Size 120	Size 160
Working stroke (in 50 mm increments) [mm]	50 ... 1000	100 ... 1100	100 ... 1400
Spindle pitch [mm]	10/20		
Max. feed force [N]	340/175	700/350	1050/260
Max. speed [m/s]	0.5/1		
Repetition accuracy [mm]	+/- 0.02		
Horizontal payload <sup>(1)</sup> [kg]	50/18	115/56	234/114
Vertical payload <sup>(1)</sup> [kg]	50/18	39/18	80/38
Payload dynamic response in 3D <sup>(2)</sup> [kg]	20		

<sup>(1)</sup> Max. acceleration 2.5 m/s<sup>2</sup> with 10 mm spindle pitch and 5 m/s<sup>2</sup> with 20 mm spindle pitch  
<sup>(2)</sup> Acceleration max. 3 m/s<sup>2</sup>, speed max. 0.5 m/s, working stroke max. 900 x 600 x 300

## Cantilever axis with toothed belt ELCC



The cantilever axis, which is available in four sizes, is extremely rigid and lightweight as well as fast and reliable. The powerful ELCC is perfect for palletising or erecting boxes in the packaging industry as well as a wide range of positioning tasks with long strokes at vertical, horizontal or other installation angles.

- Fewer vibrations and up to 50% faster settling time
- Very high acceleration and cycle times up to 30% faster
- Maximum stroke of 2 m and load of up to 100 kg
- Optional stainless steel cover band
- Optional shock absorber prevents damage during axis setup and absorbs short fall distances of a vertical installation



### Flexible motor positioning

- Freely selectable mounting direction up or down
- Can be mounted in axial, parallel or diagonal position to the axis
- Motor alignment  $4 \times 90^\circ$
- Can be modified later

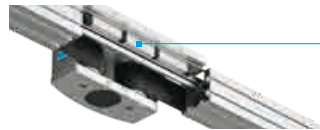

### Optional clamping unit

- Safely clamps the upright axis for a secure hold even in the event of a power failure or cable break
- Also suitable for emergency braking



### Incremental displacement encoder

Contactless position sensing with  $2.5 \mu\text{m}$  resolution, also suitable for safety-orientated dual-channel solutions. Mounting for size 60/70 on the outside and for 90/110 on the inside.



### Inductive proximity sensor SIEN-M8

Suitable for homing or end-position sensing and can be installed alongside the displacement encoder.



### Sealing air connection

Sealing air together with the cover strip minimises the number of particles that get into the guide area, e.g. in dusty environments or on machine tools.



### Rack and pinion axis EHMH

- Two sizes with a payload of up to 200 kg (vertical) and a stroke of max. 2.5 m
- Optional: clamping unit, cover pinion drive, scraper package at the guide, and displacement encoder system

Size	60	70	90	110
Guide	Recirculating ball bearing guide			
Max. stroke [mm]	1300	1500	2000	2000
Max. payload* (vertical) [kg]	10	20	60	100
Max. speed [m/s]	5			
Max. acceleration [ $\text{m/s}^2$ ]	50		30	
Repetition accuracy [mm]	$\pm 0.05$			
Max. feed force [N]	300	600	1200	2500

\* When designed using the engineering software PositioningDrives, higher loads can also be supported in some cases.

## Toothed belt axis ELGR/ELGG

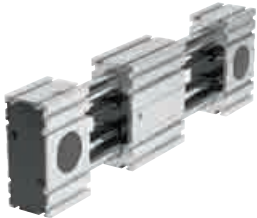

Ideal for applications with comparatively low requirements in terms of mechanical load, dynamic response and precision in a cost-optimised design. The flexibility of the ELGR and ELGG, their wide range of uses as well as their long service life of 5000 km make them perfect for simple applications needing cost-effective solutions.

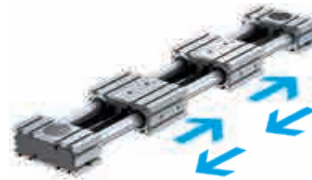

### Toothed belt axis ELGR

- One driven slide
- Optionally 1 or 2 freely moving, additional slides for an extended guide and additional mounting options

### Movement in the same direction

One slide is connected to the toothed belt, whereas the second slide moves freely and provides an extended guide.



### Toothed belt axis ELGG

- Two driven slides
- For long centring strokes in the packaging industry
- As a gripper with strokes of up to 300 mm per side and a payload of 10 kg
- As a drive for door motions

### Movement in opposite directions

The two slides are joined to the toothed belt and move synchronously in opposing directions.



### Safety thanks to optional end-position sensing:

The proximity sensor SIES-8M, together with the sensor bracket and switch lug, can be retrofitted onto the axis at any time.

- Switching output PNP or NPN
- Switching distance 1.5 mm
- Repetition accuracy  $\pm 50 \mu\text{m}$  (radial)
- Output status display: 2 yellow LEDs for improved visibility, regardless of the direction of approach
- Degree of protection IP67



### Guide variants for ELGR and ELGG

- Recirculating ball bearing guide for medium loads with very good running behaviour under torque load
- Plain-bearing guide (on request) for low loads or for use in humid environments and for non-abrasive dust



### Flexible motor connection for ELGR and ELGG

- Motor position freely selectable on 4 sides
- Position can be changed later at any time

### The benefits to you:

Create an attachment variant with one part number as standard and modify the positions as and when needed.



## Electric cylinder ESBF



The electric cylinder ESBF enables dynamic positioning with feed forces of up to 17 kN, is available in six sizes, and has a ball screw as standard. Up to size 50, it is also available with lead screw. It is based on standard ISO 15552 and its piston rod is non-rotating with a plain bearing guide. The smooth surfaces and the clean look design make the ESBF easy to clean and thus less susceptible to contamination. All that and a service life of 10,000 km.

### Cylinder options

- Guide unit
  - Recirculating ball bearing guide with high load bearing capacity
  - Absorption of lateral forces
  - Increased protection against torsion at high torque loads
- Female piston rod thread
- Extended piston rod
- Food-safe lubricant NSF-H1 for conditional use in the food sector
- Sealed motor mounting kits together with a connection for the venting hole for degree of protection IP65

### Optional position sensing

- Alternative sensor bracket (to be glued)
  - Sensor rail made of aluminium
  - Polymer sensor bracket in clean design
- Proximity sensor SME/SMT-8 for homing or position sensing

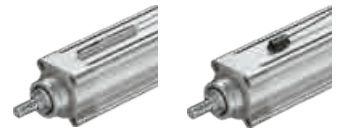

### Flexible motor mounting

- Axial mounting: freely selectable connection direction for motor cables: 4 x 90°
- Parallel mounting: freely selectable outlet direction for motor cables: 3 x 90°

### Optional protection

- Connection of the venting hole for use in harsh or contaminated environments (IP65)
- Protected piston rod, seal and bearing with a leak-proof bellows for use in highly contaminated environments



Size	32	40	50	63	80	100
Drive system/spindle type	Ball screw (BS), lead screw (LS)			Ball screw (BS)		
Max. stroke [mm]	800	800	1000	1200	1500	1500
Max. feed force [N]	1000	3000	5000	7000	12000	17000
Max. speed [m/s]	1.1	1.2	1.2	1.35	1.34	1.34
Repetition accuracy [mm]	±0.01					

## Electric cylinder EPCO



The electric cylinder with ball screw and non-rotating, plain bearing guide is available in three sizes with two pitches each. It has a permanently mounted, optimally matched motor. The smooth surfaces and clean look make the cylinder easy to clean, and thus less susceptible to contamination. The double-sided end-position cushioning reduces the impact force, stress and noise. It is powerful and compact, and has a service life of 10,000 km.

### Cylinder options

- Female piston rod thread
- Extended piston rod
- Guide unit with resilient recirculating ball bearing guide
  - Absorption of lateral forces
  - To protect cylinders against rotation at high torque loads

### Motor options

- Flexible motor mounting
  - Freely selectable connection direction for motor cables: 4 x 90°
  - Standard connection direction: upwards
- Encoder
  - With encoder for closed-loop operation
  - Without encoder: cost-optimised open-loop operation
- Holding brake



### Mounting options

- Can be screwed on from the front or using two mounting slots underneath
- Extensive mounting accessories for many different installation situations, e.g. flange, swivel or foot mounting with numerous adapters



### Optional position sensing

- Alternative sensor bracket (to be glued)
  - Sensor rail made of aluminium
  - Polymer sensor bracket in clean design
- Proximity sensor SME/SMT-8 for homing or position sensing

Size	16	25	40
Max. stroke [mm]	200	300	400
Max. feed force [N]	125	350	650
Max. speed [mm/s]	300	500	460
Max. lateral force $F_{y/z}$ [N] (with an external guide unit)	187	335	398
Repetition accuracy [mm]	±0.02		

## Electric cylinder EPCC



The powerful yet affordable electric cylinder EPCC is suitable for simple positioning tasks. Thanks to the ball screw, it is precise and fast as well as sturdy and resilient. Its compact dimensions are ideal when installation space is limited, e.g. in assembly systems, test and inspection systems, desktop applications, small parts handling or the electronics industry. The weight-optimised design improves dynamic response and reduces cycle times.

### Technical highlights of the EPCC

- High grade ball screw with low internal friction for smaller motors, i.e. less weight, installation space and electrical power required
- Space-saving integration of double bearing and coupling to absorb drive forces and torques
- Unique "one-size down" assembly ensures adapter-free mounting on the ELGC for optimised use of the installation space as well as less weight for greater dynamic response



### Optional ducted air pressure compensation

- No particles or moisture are drawn from the environment into the electric cylinder
- No particles are emitted from the drive into the environment



### Very flexible motor mounting

Free choice of motor positions and mounting kits, can also be changed at a later date:

- Axial kit: motor position rotated 4 x 90°
- Parallel kit: mounting direction rotated 4 x 90 and motor position rotated 3 x 90°



### Cost-effective position sensing

- Simple and cost-effective sensing with magneto-resistive proximity sensor SMT-8M
- Sensor bracket for flexible, secure and rapid mounting on the profile
- Can be extended or repositioned at any time

Size	25	32	45	60
Drive system/spindle type	Ball screw drive/lead screw drive			
Stroke length [mm]	25 ... 200	25 ... 200	25 ... 300	25 ... 500
Max. feed force [N]	75	150	450	1000
Max. speed (low/high) [mm/s]	133/400	188/500	180/600	250/600
Spindle pitch (low/high) [mm/U]	2/6	3/8	3/10	5/12
Max. rotational speed [rpm]	4000	3750	3600	3000
Max. acceleration [m/s <sup>2</sup> ]	15			
Repetition accuracy [mm]	±0.02			

## Mini slide EGSL



The electric slide EGSL is designed for outstanding performance when it comes to precision, high load capacity and dynamic response, even in compact spaces. This makes it a favourite for high-precision positioning and strokes of up to 300 mm. Its strengths are shown to good advantage, especially in vertical applications and short-stroke slide functions with variable positioning such as very accurate pushing, picking and insertion with linearity and parallelism in the 1/100 mm ranger, even with high mechanical loads!

### Benefits

- Precise and free positioning with a repetition accuracy of max.  $\pm 0.02$  mm
- Perfect for vertical applications such as press-fitting or joining
- The guide area is protected against contamination and small parts because the spindle is fully closed; an additional cover for the guide is optional
- Simple, low-cost sensing with integrated sensor slots on the right and left
- Matching software tools for engineering (Positioning-Drives), configuration, commissioning and more with the software package Festo Configuration Tool (FCT)

### Motor attachment variants

Greater flexibility thanks to lateral or axial motor mounting options. The motor can be easily adapted to the installation space: when mounted in axial direction it can be rotated 4 x 90°, and in lateral direction it can be rotated 3 x 90°.



Size	35	45	55	75	
Working stroke [mm]	50	100, 200	100, 200, 250	100, 200, 300	
Max. speed [m/s]	0.5	1.0	1.0	1.3	
Feed force $F_x$ [N]	75	150	300	450	
Torque	$M_x$ [Nm]	6.2	18.6	33.1	67.4
	$M_y$ [Nm]	6.0	16.3	33.3	47.1
	$M_z$ [Nm]	6.0	16.3	33.3	47.1
Repetition accuracy [mm]	$\pm 0.015$				
Max. horiz./vert. payload [kg]	2	6	10	14	

## Mini slide EGSC



The compact mini slide EGSC offers very cost-effective yet precise positioning. The internal, protected recirculating ball bearing guide absorbs forces and torques, the compact ball screw ensures quiet spindle operation while the life-time lubrication guarantees a long service life. The mini slide is ideal in very small installation spaces or when cost efficiency is important, e.g. in the electronics industry, desktop applications, assembly systems, small parts handling or in test and inspection systems.

With the unique “one-size down” assembly system and its universal mounting profile no additional adapters are needed for direct mounting. In combination with the rotary drive ERMO and the axis series ELGC, space-optimised and very economical 2D and 3D handling systems can be easily and flexibly created.



### Optional ducted air pressure compensation

- Pressure compensation air can be ducted subsequently using fittings and tubing
- No particles or moisture are drawn from the environment into the electric cylinder
- No particles are emitted from the drive into the environment



### Very flexible motor mounting

Free choice of motor positions and mounting kits, can also be changed at a later date:

- Axial kit: motor position rotated 4 x 90°
- Parallel kit: mounting direction rotated 3 x 90° and motor position rotated 3 x 90°



### Pick & place solution

Compact solution to precisely position and align workpieces even with high loads

- Adapterless, cost-effective direct mounting of both mini slides EGSC and the rotary drive ERMO
- Mechanically rigid and sturdy design with precision positioning

Technical data	
Design	Electric mini slide with ball screw
Sizes	25 / 32 / 45 / 60
Working stroke [mm]	25 ... 200
Max. feed force [N]	20 / 60 / 120 / 250
Max. speed [m/s]	0.6
Max. acceleration [m/s <sup>2</sup> ]	15
Repetition accuracy [µm]	± 15

## Parallel gripper EHPS



The electric EHPS allows flexible and economical gripping in handling and assembly technology, as well as in the electronics industry or small parts assembly. It can also be used wherever mono-energetic, electrical power-based systems or solutions are required; and especially in clean environments where compressed air is not permitted.

It is characterised by its ease of use, minimal installation effort and safe operation

- Quick commissioning without external controller
- Easy 4-step adjustment of the gripping force all the way up from 50% to the maximum via a latched switch
- IO-Link® communication
- Self-locking in the event of a power failure prevents losing the product being gripped



### Optional position sensing of the gripper jaw

- Easy and low-cost sensing:
  - Proximity sensor SMT-8M/-8G
  - Position transmitter SMAT
- Flush mounting in the sensor slot
- Can be extended at any time

Size	16	20	25
Max. gripping force [N]	50	90	125
Opening angle per jaw/total [mm]	10/20	13/26	16/32
Repetition accuracy [µm]	30	10	10
Closing time [s]	0.3	0.42	0.44
Max. cycle rate [Hz]	2.2	1.7	1.3
Weight [kg]	0.31	0.54	0.9
Degree of protection	IP40		
Connecting cable	Cable length 0.3 m, plug 5-pin M12x1		
Operating voltage [VDC]	24		



## Electric stopper cylinder EFSD



The EFSD stops workpiece carriers or packaging goods. Thanks to the direct correlation of load and conveying speed, the stopper can stop, for example, 100 kg at 6 m/min or up to 20 kg at 36 m/min. The stopper has cushioning that protects the transported goods as well as the stopper and that can be adjusted on site. The cushioning module operates using ambient air, is easy to maintain and to install.

It is actuated and controlled directly by the higher-level control system via digital I/O; no additional controller is required thanks to the internal logic. M12 plugs are used for the connection for the drive and position sensing for sensing the upper and lower position of the stop (extended or retracted). In addition, the electric stopper EFSD is designed to be energy-saving, because the motor automatically switches off in the end positions; this means that no energy is needed to hold or continuously open the line.

- Quick and easy set-up of transfer systems without compressed air
- Three sizes for stopping transported goods weighing between 0.25 kg and 100 kg (the size is determined by the conveying speed and the load)
- Actuation via digital I/O simplifies commissioning
- Integrated sensor technology for position sensing (stop retracted or extended)
- LED display: status and error message for visual error diagnostics
- Easy to mount onto the transfer system using two retaining screws
- Easy electrical connection for input and output signals via two cables with 5-pin M12x1 plug

### Use in transfer systems

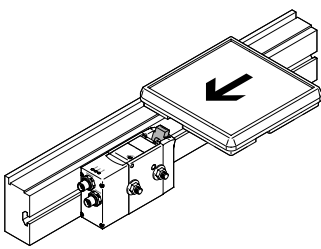

This stopper is specifically designed for use in transfer systems, where objects are transported from one processing station to the other. The EFSD can be mounted directly on the profile of the transfer system with just two screws.

### Functional sequence "stop"

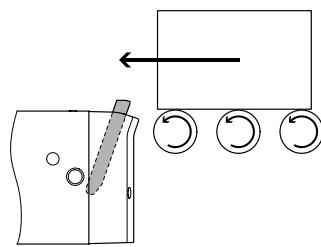

#### Position 1 Stopper cylinder is in the initial position

The stopper is extended and ready to stop the transported material

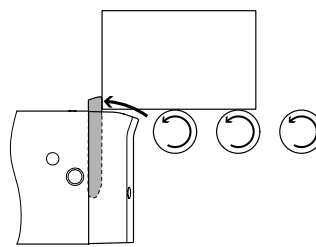

#### Position 2 Stopper cylinder is in the stop position

Transported material has been slowed down by internal cushioning and kept in position

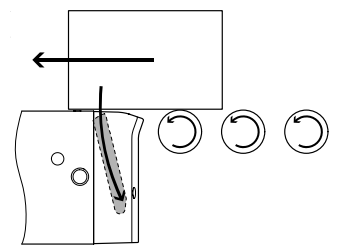

#### Position 3 Stopper cylinder is in release position

Stopper is retracted and releases the transported material

## Rotary drive ERMO



The rotary drive ERMO has a sturdy and backlash-free bearing to absorb high forces and torques. The stepper motor, gear unit and sealed hollow shaft are all integrated. It is an ideal electromechanical complete solution for rotating and aligning parts and workpieces or for swivelling tasks subjected to heavy loads. It is also suitable for simple rotary indexing table applications such as at manual workstations. With the optional external mounting kit, the swivel angle can be limited to max. 270°.



### Motor and connecting cables

- The motor can be mounted and rotated 3 x 90°
- Position can be changed later at any time
- Cables in IP54 suitable for energy chains for power supply (load) and encoder, up to 10 m in length

### Optional reference sensor

- Inductive proximity sensor SIEN with M8 connection integrated in the housing
- For homing or position sensing
- Ideal for multi-turn applications
- Degree of protection IP67



### Mounting interfaces

- Interfaces on flange and housing, identical to the pneumatic semi-rotary drive DSM/DSM-B
- Interfaces suitable for connection to other electromechanical components, e.g.
  - Electric cylinder EPCO
  - Electric slide EGSL
  - Electric slide EGSC



### Optional energy through-feed for infinite rotation

- Kit for energy through-feed including suitable connection technology
- Pneumatic, e.g. for grippers, including plug connectors for tubing
  - Electric, e.g. for sensors or the transmission of IO-Link® signals, including 8-pin M12 plug and socket

Size	12	16	25	32
Flange size [mm]	58 x 58	68 x 68	83 x 83	105 x 105
Torque [Nm]	0.15	0.8	2.5	5
Speed [°/s]	600	600	400	300
Repetition accuracy [°]	±0.05	±0.05	±0.05	±0.1
Max. axial/radial torque [N]	500/500	600/750	700/1200	800/2000

## Rotary module ERMB



Rotary drive module with motor and sensing module EAPS (optionally with additional housing)

Weights of up to 15 kg can be rotated dynamically and flexibly with the freely positionable, electric rotary module ERMB.

The module can be used as an axis of rotation with any rotation angle  $>360^\circ$  or as a small, stand-alone NC rotary table.

Mounting interfaces on all sides and the large hollow shaft diameter on the high-strength rotary flange make installing the module exceptionally easy.

### Matching range of motors

Using servo or stepper motors simplifies the uniform closed-loop controller concept, while the universal software platform simplifies commissioning and activation. The ERMB's performance adapts to the requirements depending on the motor technology used.

### Adaptable safety

Sensing module EAPS can be used to define impermissible fields. The freely adjustable index pins in the retaining ring is sensed using two inductive sensors.

### Reduced vibration

The rotary module ERMB minimises vibrations in multi-axis systems, thereby increasing their performance thanks to uniform movements and user-defined acceleration ramps. The movements into the end positions are smooth and wear-free.

### Technical data

- 3 sizes: 20, 25, 32 with a max. output speed of 300 rpm
- Repetition accuracy:  $\pm 0.03/0.05/0.08^\circ$

### Positioning time

- Min. positioning time at swivel angle of  $180^\circ$ :  $<0.18$  s

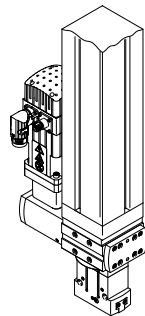

Rotary drive module with gripper on a Z axis

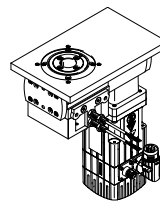

Rotary drive module as small NC rotary table

## Highly dynamic rotary/lifting module EHMB



This extremely compact handling unit combines rotary and linear movements that can be positioned independently of each other.

The max. payload is 8 kg. Positioning for a 1 kg load time at swivel angle of  $180^\circ$  is 0.25 s

## Servo drive CMMT-AS



The CMMT-AS is one of the most compact servo drives on the market for low-voltage controllers. The compact servo drive for point-to-point and interpolating motion is suitable for different Ethernet-based bus systems and can be seamlessly and directly integrated in the system environments of various manufacturers. And commissioning with the Festo Automation Suite only takes a few minutes.

The well-thought-out design ensures free and convenient access to the connections and control elements. All connections and the detachable control unit CDSB are mounted at the front and on top of the closed-loop controller. Its compact design and optimised connection technology permits easy and space-saving installation in the control cabinet together with much shorter connection times.

- Direct fieldbus integration for the main controller manufacturers
- Configure standard safety functions without software: STO, SS1, SBC
- Extremely low width, depth and height of the controller and unique high-density assembly thanks to good series connection of multiple controllers
- Optimally with servo motor EMMT-AS
- Full parameterisation for commissioning series machines directly via your master controller with PROFINET and EtherCAT®



### System integration with third-party manufacturers

The servo drive CMMT-AS can also be integrated directly into the system environment of a third-party manufacturer and behaves like a controller from that controller manufacturer. The identical behaviour means that no controller-specific expertise is required for the CMMT-AS.

The prerequisite for perfect integration of an EtherNet-based protocol such as PROFINET, PROFIBUS, EtherNet/IP, EtherCAT or Modbus®. Function blocks are available for several manufacturers such as Siemens, Rockwell, Beckhoff and Omron.

EtherCAT®

EtherNet/IP™

PROFI  
NET

Modbus



### Commissioning software Festo Automation Suite

The PC-based software seamlessly combines parameterisation, programming and maintenance in one program, from the mechanical system to the controller. The entire drive package can be commissioned in just five steps, and be integrated into the control system CPX-E in just two clicks.

Important technical data of the CMMT-AS	
Applications	Point-to-point and interpolating motions
Nominal power	1 phase 230 V: 0.35/0.7 kW, 3 phase 400 V: 0,8/4/6 kW
Communication	EtherCAT®, PROFINET, EtherNet/IP, Modbus®
Safety functions	STO, SS1, SBC, (SS2, SOS, SLS, SSR) *
Multi-encoder input motor Additional encoder input	ENDAT2.1/2.2 (one cable), HIPERFACE, Nikon ENDAT2.2, Nikon, A/B- and SIN/COS incremental
Mains filter	Integrated
Intermediate circuit coupling	Yes
Engineering, commissioning, programming	PositioningDrives Festo Automation Suite (including first commissioning wizard), Autotuning CODESYS

\* On request

## Servo motor controller CMMP-AS



CMMP-AS-M3

This range of servo motor controllers (CMMP-AS) provides an extremely functional solution for dynamic movements and is perfect for the electronic control of cam discs.

CMMP-AS-M0 as the basic variant with standard functions and CMMP-AS-M3 with expansion options, e.g. for an EtherCAT® connection or a safety module.

The software tools from Festo offer a universal concept from commissioning and programming right through to parameterisation

- Convenient and easy operation
- SD card for parameters and firmware

### Integrated safety function

- Integrated safe stop with restart blocking for safety-orientated applications
- Safe torque off (STO) up to category 4, PLe integrated
- Further safety functions like SLS can be realised using optional components
- Solution examples available

The integral software platform and Festo Configuration Tool (FCT) and the standardised data profile FHPP ensure problem-free commissioning, programming and parameterisation.

### Technical data and functions

- Motor current
  - Single-phase: 2.5 and 5 A
  - Three-phase: 5 and 10 A
- 256 integrated position records
- Automatic motor brake
- Speed and position control
- Current and torque control

- Jerk-free positioning
- Infinitely variable positioning in closed-loop operation
- Flying measurement
- Electronic cam disc
- Flexible software limit switches
- External braking resistor (optional)

CANopen

PROFI  
NET

PROFI  
BUS

EtherCAT

DeviceNet

EtherNet/IP

## Servo drive CMMT-ST



Like its big brother the CMMT-AS, the extra-low voltage closed-loop controller CMMT-ST is an integral part of the Festo Automation Platform. It offers extremely economical positioning tasks and motion solutions with low power requirements up to 300 W.

As it is part of the same platform as the CMMT-AS, it is suitable for different Ethernet-based bus systems and can also be seamlessly and directly integrated in the system environments of various manufacturers. Commissioning with the Festo Automation Suite also just takes a few minutes.

Though more compact and much cheaper than its big brother the CMMT-AS, the connection and communication concept, functional modules and standard safety features remain unchanged. The consistent control concept means that the CMMT-AS and CMMT-ST as a drive can be easily combined with both large and small axes.

EtherCAT®

EtherNet/IP™

PROFINET

- Max. continuous output: 300 W
  - Primary voltage: 24 ... 48 V DC
  - Motor current: 8 A/peak 10 A
  - Point-to-point and interpolating motion as well as precise positioning
  - 50% more compact than the smallest CMMT-AS
  - Direct fieldbus integration for the main controller manufacturers
  - Configure standard safety functions without software: STO, SS1
  - Optimally with proven stepper motor EMMS-ST
  - Thanks to an identical platform, it has the same connection and communication concept, functional modules and standard safety features as the CMMT-AS
  - Full parameterisation for commissioning series machines directly via your master controller with PROFINET and EtherCAT®
- The identical platform means that CMMT-AS and CMMT-ST can be combined.



**Commissioning software  
Festo Automation Suite**

The PC-based software seamlessly combines parameterisation, programming and maintenance in one program, from the mechanical system to the controller. The entire drive package can be commissioned in just five steps, and be integrated into the control system CPX-E with just two clicks.

CMMT-ST

CMMT-AS

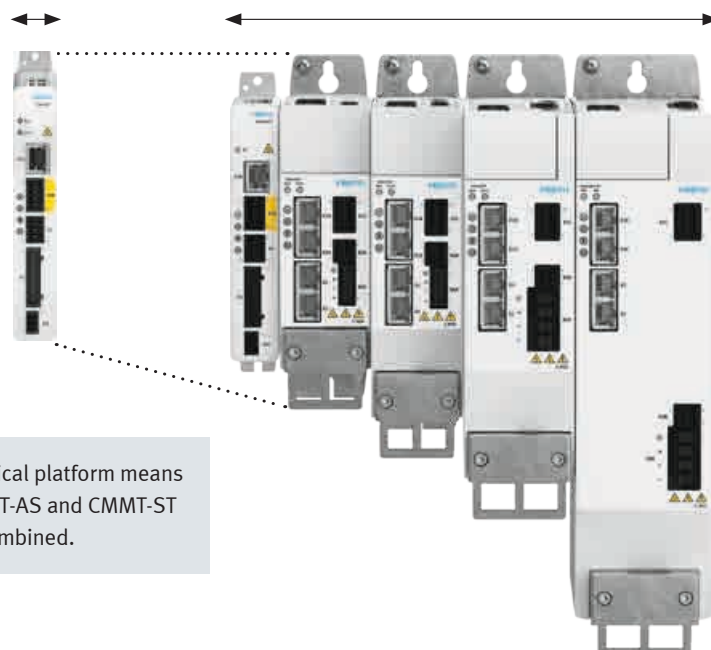

The identical platform means that CMMT-AS and CMMT-ST can be combined.



## Stepper motor controller CMMS-ST



Stepper motor technology in a real Festo plug & work solution package: the single-axis position controller (servo drive) CMMS-ST combined with stepper motors EMMS-ST for single and multi-axis handling applications with moving loads of up to 20 kg.

The CMMS-ST is a fully fledged closed-loop servo system for the highest degree of operational safety and fast dynamic response by using the best possible motor characteristic curve. Alternatively, the CMMS-ST can also be used as a low-cost open-loop system with stepper motors without encoders.

### Integrated safety function

- Safe torque off (STO) up to category 3, PLd integrated
- Further safety functions can be realised using external components
- Solution examples available

CANopen

PROFI  
BUS

DeviceNet

### Technical data and functions

- Primary voltage: 24 ... 48 V DC
- Motor current: 8 A/peak 12 A
- 63 integrated position records, e.g. acceleration ramps

- Automatic motor brake
- Jerk-free positioning
- Infinitely variable positioning
- The digital inputs and outputs are protected against short circuit, overload and reverse voltages

The integral software platform and Festo Configuration Tool (FCT) and the standardised data profile FHPP ensure problem-free commissioning, programming and parameterisation.

## Motor controllers CMMO-ST



The motor controller (drive system) CMMO-ST is a closed-loop servo controller for stepper motors and offers a broad connectivity such as IO-Link®, Modbus TCP or I/O interface.

As a fully fledged closed loop servo system with jerk-limited acceleration, it uses the best possible motor characteristic curve for the highest degree of operational safety and fast dynamic response.

### Functions

- Monitoring of freely defined positions and torque ranges
- Monitoring of different process variables such as torque, speed, position and time
- Positioning mode with optional torque limiter
- Force mode with optional stroke limit
- Speed mode with stroke and force limitation

### Key technical data

- Power supply 24 V DC for logic and load (separate)
- Maximum motor current: 5 A
- Safety: STO/cat. 3, PLd
- Degree of protection: IP40
- IO-Link® and Modbus® TCP
- I/O interface (7 freely definable positions via directly allocated I/Os)

IO-Link

Modbus

## Servo motor EMMT-AS



The AC synchronous servo motor for demanding and dynamic applications is noted for an extremely low standstill torque. This ensures good adjustability and tracking accuracy for positioning tasks. The "electronic rating plate" contains all the important motor data. It can be read by the servo drive CMMT-AS and thus the parameters for the servo motor will be automatically

set. This makes commissioning effortless and totally reliable.

- 3 sizes 60/80/100 with up to 2.6 kW / 9.8 Nm
- Single-turn or multi-turn absolute encoder
- With or without holding brake
- Smooth, painted surface that is dirt-resistant and easy to clean
- Degree of protection IP67: complete housing and connection technology (including plug)

- Degree of protection IP40 on the shaft, optionally IP65 with sealing ring suitable for unlubricated operation
- Temperature measurement integrated in motor, interference-proof and digital transmission via the encoder protocol

### Space-saving, one cable solution

The space-saving one cable plug (OCP) requires much less installation effort. The servo motor is connected with only one cable for power, encoder signals and holding brake. This simplifies wiring and replacement.



- It is suitable for transmitting higher electrical power
- Robust and durable for dynamic applications, e.g. in energy chains
- Long cables for distances over 50 m
- Cable lengths up to 100 m with improved protection against interference



### Commissioning software Festo Automation Suite

The PC-based software seamlessly combines parameterisation, programming and maintenance in one program, from the mechanical system to the controller. The entire drive package from CMMT-AS and EMMT-AS can be commissioned in just five steps, and be integrated into the control system CPX-E in just two clicks.

## Servo motor EMME-AS



Designed for dynamic positioning tasks: the servo motors EMMS-AS with ten torque ranges.

- Single-turn encoder (standard)
- Multi-turn encoder with SIL (optional)
- Optional holding brake
- Degree of protection
  - IP65 for motor housing and power/encoder connection
  - IP21 on the motor shaft

## Servo motor EMMB-AS



This compact and particularly economical synchronous servo motor in four power classes is perfect for simple positioning tasks, particularly in the electronics industry and small parts assembly as well as in test stations.

- Single-turn encoder, optional: multi-turn with battery adapter
- Optional holding brake

- Motor, brake and encoder cables with optimised connection technology
  - 2.5 ... 25 m
  - Suitable for energy chains
- Degree of protection:
  - IP65 for motor housing and cable connections on the motor
  - IP40 on the motor shaft without shaft seal ring and IP54 with shaft seal ring
- Compatible with shafts and flanges on the EMMT-AS

## Stepper motor EMMS-ST



The stepper motor series EMMS-ST is designed for two-phase hybrid technology. In addition to the simple and cost-effective connection technology, the motors stand out above all thanks to the problem-free operation and the long service life.

- Four sizes with flange sizes 28, 42, 57 and 87
- Conforms to IEC 60034 standard
- Optional encoder for closed-loop function
- Optional motor brake
- Degree of protection:
  - Motor housing and plug connection in IP54
  - Motor shaft IP40

### **Matching range of planetary gear units**

- Gear ratio  $i = 3$  and  $5$ ; others available on request
- Life-time lubrication
- Degree of protection: IP54

### **Matching motor and encoder cables**

- Five standard lengths from 1.5 m to 10 m; others available on request
- Shielded cables
- Suitable for energy chains
- Degree of protection IP65



## Integrated drive EMCA



The complete solution EMCA for positioning electromechanical drives and for format changes consists of a maintenance- and wear-free EC motor and a motor controller (servo drive). The power electronics are also integrated. That avoids long motor cables, improves the electromagnetic compatibility and reduces the installation time and space requirements.

Integrated monitoring functions ensure reliability and availability. Absolute position sensing is included as standard via a single-turn or optionally via a multi-turn encoder. External gear units are available for optimal adaptation to different positioning tasks or format changes.

Parameterisation and commissioning are carried out with the Festo Configuration Tool FCT.

### Key features

- 64 freely programmable position records
- Multi-turn encoder with buffering (resolution up to 32 bit or > 4 billion revolutions)
- One size with identical flange dimensions in 2 lengths with performance classes 120 W and 150 W
- Degree of protection IP54 is standard and IP65 is optional, for direct installation in the system
- Optional holding brake and external gear unit

### Technical specifications

- Nominal power 120/150 W
- Peak power 200 W
- Nominal torque 0.34/0.46 Nm
- Maximum torque 0.78 Nm

CANopen

PROFI  
NET

EtherCAT

EtherNet/IP

Modbus



Integrated drive for format changes as a replacement for a handwheel

## Real-time capable, fast and compatible: decentralised remote I/O system CPX-AP-I

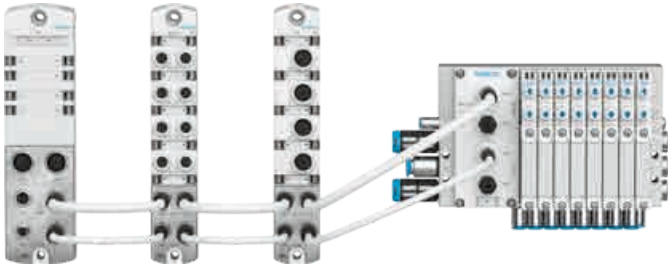

**With real-time capability, short bus cycles and speeds that are twice as fast as current Ethernet-based networks, the CPX-AP-I is ideal for fast production processes and high-speed data transfer**

The sturdy, compact and ultra-lightweight remote I/O is compatible with all host systems commonly found on the market. With up to 80 modules, it can be flexibly integrated into applications of any scale and is optimally suited for those applications where low weight and minimal installation space are

called for, whether in handling and tool changing systems or in mobile applications, for example at the robot front end. Thanks to cable lengths of up to 50 m between the individual modules, CPX-AP-I is also the first choice in systems and intralogistics where large distances matter.

### AP system communication

The new AP communication technology combines a host PLC with IO-Link® devices, digital and analogue inputs and outputs, and data transfer to the cloud in a simple package. What makes it unique is the

direct integration of existing Festo valve terminals into the remote I/O system.

- Simplified engineering without additional software
- Real-time communication to the valve terminal

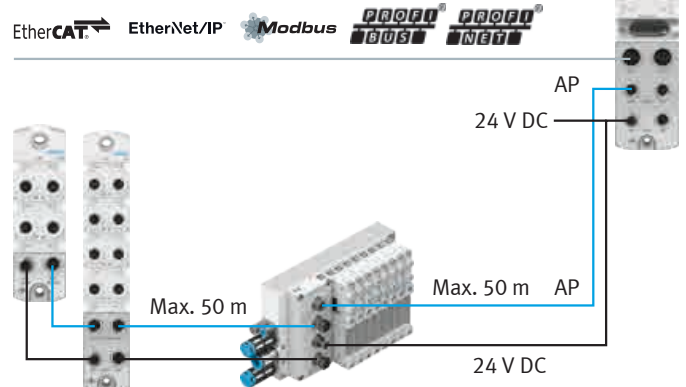

### IO-Link® with CPX-AP-I

You can integrate up to four IO-Link® devices per IO-Link® master into the CPX-AP-I system and connect several IO-Link® masters to a bus interface.

IO-Link® products from Festo:

- Simplified Motion Series
- Servo drives
- Grippers
- Sensors
- Festo valve terminals
- Proportional pressure regulators

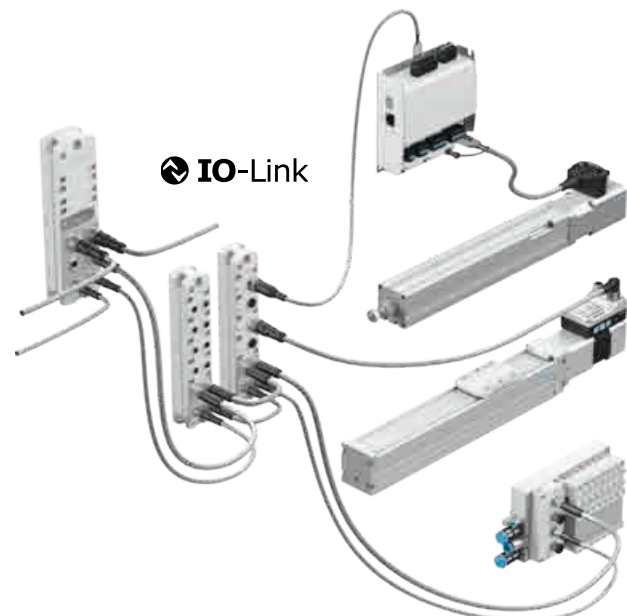



## Decentralised remote I/O system CPX-AP-I

### Bus interface



PROFINET

#### CPX-AP-I-PN-M12

- Web server
- Isochronous real time (IRT)
- Fast start-up (FSU)
- Redundancy mechanisms MRP, MRPD, S2
- Support for LLDP, DCP, CiR, SNMP, SNTIP
- Dimensions (W x L x H)  
45 x 170 x 35 mm
- Product weight 186 g



PROFIBUS

#### CPX-AP-I-PB-M12

- Class 1 and Class 2 capable
- Dimensions (W x L x H)  
45 x 170 x 35 mm
- Product weight 186 g



Modbus  
EtherNet/IP

#### CPX-AP-I-EP-M12

- Web server
- QuickConnect
- Redundancy mechanism DLR
- Modbus TCP
- CIP Sync (in future)
- Dimensions (W x L x H)  
45 x 170 x 35 mm
- Product weight 186 g



EtherCAT

#### CPX-AP-I-EC-M12

- EtherCAT profiles: CoE, EoE, FoE
- Fast Hot Connect, distributed clocks
- Dimensions (W x L x H)  
45 x 170 x 35 mm
- Product weight 194 g

### IO-Link master and I/O modules



#### IO-Link master

##### CPX-AP-I-4IOL-M12

- IO-Link master class B
- Festo IO-Link tool
- 2 A output current per port (4 A resultant current of all ports)
- M12 connection technology
- Dimensions (W x L x H)  
30 x 170 x 35 mm
- Product weight 126 g



#### Digital input modules

##### CPX-AP-I-4DI-M8-3P

- 4-way compact module
- M8 connection technology
- Smallest and lightest I/O module on the market
- Dimensions (W x L x H)  
30 x 102.5 x 35 mm
- Product weight 81 g

##### CPX-AP-I-8DI-M8-3P/-M12-5P

- 8-valve module
- M12 and M8 connection technology
- Parameterisation of input debounce time
- Dimensions (W x L x H)  
30 x 170 x 35 mm
- Product weight 126 g



#### Analogue input module

##### CPX-AP-I-4AI-U-I-RTD-M12

- Measuring range/method:
  - 0/4 ... 20 mA, 0 ... 10 V,
  - 1 ... 5 V, +/- 5 V, +/- 10 V
  - PT100/Ni100, 500 ohm
- 16-bit analogue value
- 1 ms cycle time
- Linear scaling
- M12 connection technology
- Dimensions (W x L x H)  
30 x 170 x 35 mm
- Product weight 166 g



#### Digital input/output modules

##### CPX-AP-I-4DI4DO-M8-3P/-M12-5P

- Isolated outputs
- 0.5 A nominal current per output
- M8 and M12 connection technology
- Dimensions (W x L x H)  
30 x 170 x 35 mm
- Product weight 129 g

## Intelligent connectivity: controllers and motion control



### Control system CPX-E

High-performance automation system as an EtherCAT master controller and motion controller to IP20 or as a low-cost remote I/O.

- Comprehensive PLC functions, multi-axis applications with interpolation
- Easy to integrate in host systems or as a controller for decentralised automation solutions
- For Industry 4.0 host environments: cloud and digitalisation concepts, OPC UA client and server functions

Permitted axes: individual axes open in accordance with EtherCAT® specification or 16 interpolating axes

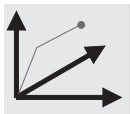

C1: Single axis

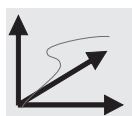
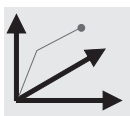

Robotics (3D)



### Electrical terminal CPX

CPX is used as a modular and flexible automation platform, including embedded CODESYS controller, or as a versatile remote I/O in IP65 for scalable installation concepts. For universal communication via fieldbus/Ethernet.

- For decentralised and networked intelligence
- Industry 4.0 thanks to OPC UA and CODESYS V3
- Optimised versions for IP20 and potentially explosive environments
- Diagnostics and condition monitoring, also via IoT gateway and Festo Cloud

Permitted axes: 128 individual axes or 31 interpolating axes

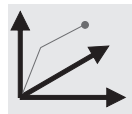

C1: Single axis

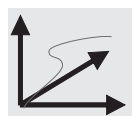
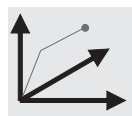

M1: Interpolation (3D)



### Compact controller CECC

The versatile controller with CODESYS is ideal for simple control of electric and pneumatic drives. CECC stand-alone or as part of mechatronic solutions enables interpolating motion control for up to 3 axes.

- IO-Link® variant with master and device interface
- Direct connection of the Simplified Motion Series via IO-Link®
- Integrated IO-Link® interface for connecting Festo valve terminals, electric drives, sensors
- Digital I/O

Permitted axes: 4 axes

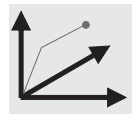

Single axis (PTP asynchronous)



### Operator unit CDPX

The front end display CDPX with touchscreen visualises data and simplifies the communication with machines and systems. Project engineering and programming are easy and intuitive.

- CODESYS controller, CANopen master, digital and analogue I/O modules for easier control at field level
- Optional: digital and analogue I/O

Permitted axes: 8 axes

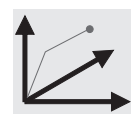

Single axis (PTP asynchronous)

# Modular control system CPX-E



CPX-E is a powerful automation system and, as an EtherCAT® master controller and motion controller to IP20, is the central control system for handling applications. The version without control unit is a compact and affordable remote I/O including different bus modules.

Thanks to comprehensive PLC functions and multi-axis applications with interpolation, the CPX-E can be easily integrated into existing host systems. The OPC UA client and server functions ensure easy integration and interoperability in Industry 4.0 host environments with cloud and digitalisation concepts.

- Fast EtherCAT® master interface
- Bus slave interfaces: PROFINET, Ethernet/IP
- High performance (dual core processor with 766 MHz and 512 MB RAM)
- USB interface and SD card interface
- Display optional
- CODESYS V3 as of SP10
- Motion functions such as SoftMotion
- UL/CSA, C-Tick, IEC Ex certifications



### Remote I/O modules

- Digital input modules (16 DI)
- Digital output modules (8 DO/0.5 A)
- Analogue input module (4 AI current/voltage)

- Analogue output module (4 AO current/voltage)
- IO-Link® master modules (4 channels)\*
- Counter module

### The control options of the CPX-E

- CPX-E-CEC-C1: powerful CODESYS V3 control unit with comprehensive PLC functions, but without any motion control functions
- CPX-E-CEC-M1-EP: motion controller with CODESYS V3 and SoftMotion

### Architecture of the automation system CPX-E

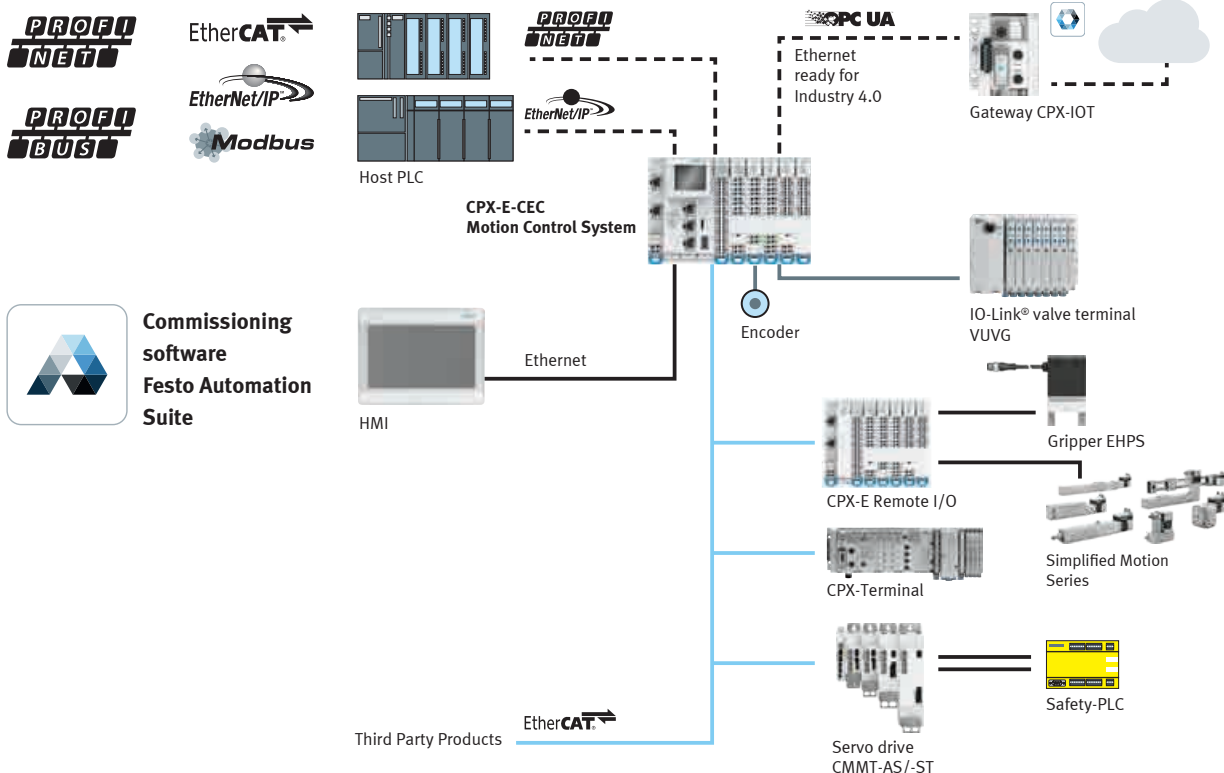

## Terminal CPX



The CPX terminal is used as a modular and flexible automation platform, including embedded CODESYS controller, or as a versatile remote I/O in IP65. With CPX, you can integrate pneumatic and electrical control chains easily, quickly, flexibly and, above all, seamlessly into all automation concepts and company-specific standards. This makes CPX the perfect platform for electrical peripherals of a machine with decentralised and networked intelligence. It is a forward-looking technology that can now be connected to host environments for Industry 4.0 as well as to the Festo Cloud and others via the IoT gateway.

Perfect networking thanks to:

- Universal communication via fieldbus/Ethernet
- A choice of pneumatic platforms (valve terminals)
- Subordinate, decentralised installation systems CPI, IO-Link® or I-Port
- Maximum range of modules for almost any automation requirement

Extensive function integration

- Front-end control
- A choice of scalable installation concepts
- Comprehensive diagnostics and condition monitoring, also via an IoT gateway and the Festo Cloud
- Motion control for electric and servo-pneumatic drives



DeviceNet

CANopen

EtherNet/IP

EtherCAT

**SERCOS**  
the automation bus

**Festo Cloud via CPX-IOT Gateway**  
OPC-UA/AMQP/MQTT

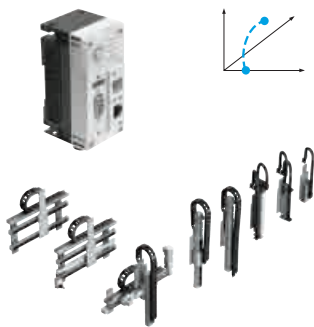

CODESYS controller with CANopen master for multiple asynchronous axes



### Motion control with CPX-CEC-C1-V3

An intelligent remote directly I/O terminal in IP65/IP67 mounted directly on the machine for decentralised control tasks in the machine.

- Extensive CODESYS function library
- Integrated CANopen master for several thousand I/Os as variant CPX-CEC-S1-V3 without CANopen master
- Motion control with up to 127 asynchronous electric drives



Additional CODESYS SoftMotion library for 3-dimensional interpolation



### Motion control with CPX-CEC-M1-V3

As the CPX-CEC-C1, with additional CODESYS SoftMotion library. This allows the controller to perform three-dimensional interpolation for up to 31 synchronous, electric axes. With flexible electronic camming functions and CNC editor included.

**New:** predefined profiles are available as function blocks and visualisation components for highly dynamic handling systems (→ page 52/53) ("Festo Robot Lib").

## Compact controller CECC



The CECC is a versatile controller with CODESYS V3 provided by Festo and offers a huge number of functions on a compact device. With the CECC, electric or pneumatic drives are easy to control, especially for small tasks. The innovative, object-oriented programming and function library for motion control for interpolating up to 3 axes make operation and programming very easy.

### **CECC-D with basic functions:**

- CANopen master for connecting with servo drives
- Ethernet, Modbus® TCP client/server, EasyIP, TCP/IP, OPC server are available
- 12 digital inputs, 8 digital outputs, 2 high-speed counters of up to 180 kHz

### **CECC-S with additional interfaces:**

- IO-Link® master and device
- RS232, RS422, RS485 for free programming or as a direct encoder interface

### **CECC-LK with IO-Link®:**

- Four IO-Link® masters and one IO-Link® device interface
- Easy to connect with sensors and valve terminals
- Direct connection with the Simplified Motion series

OPC UA client server is available on request, making CECC ready for Industry 4.0.

- MQTT can be configured with CODESYS.

## Operator unit CDPX



CDPX as a front end display with a touchscreen simplifies the communication with machines and systems. Simple intuitive project planning and programming is carried out with the Designer Studio. The operator unit with perfect graphic display visualises data, and operates as a worldwide server for external clients.

With the addition of a CODESYS controller, CANopen master and digital and analogue I/O modules, a Programmable Automation Controller (PAC) is created, thus simplifying the control of automation tasks at field level. Festo valve terminals, servo drives and other products can now be connected directly via CANopen.

- Four display sizes up to 13.3" and 1280 x 800 pixels
- Additional functions such as:
  - Data presentation in numerical, textual and graphic form
  - Data collection and trend display
  - IP camera image display
- Analogue and digital inputs and outputs optional

## Functional safety

Safety engineering in factory automation or the process industry is one of the key requirements for any machine and system builder.

Our products and solutions provide the ideal prerequisites for implementing safety engineering as economically and easily as possible.

Regardless of whether this is electrical, mechanical or in combination with controllers.



### PROFIsafe I/O modules to CPX

The scalable PROFIsafe input and output modules of the automation platform CPX cover the entire local safety chain thanks to IP65/67. Multiple PROFIsafe modules per CPX are possible.

Safe inputs:

- 4 safe inputs for integrating sensors or floating contacts
- Reliable detection and evaluation of input statuses up to category 4, PL e/SIL 3

Safe outputs:

- Safely switching off the supply voltage for valves
- Safe outputs for further external devices
- Safe switch-off in accordance with category 3, PL e/SIL 3



### Servo drives and motor controllers

The safety function STO is integrated as standard into all servo drive packages. This allows easy implementation of the

emergency stop requirements with safe stop SS1 up to category 3, PLd. For stricter requirements, optional safety modules provide further safety functions up to category 4, PL e.

See page 34-37 for details



### Intelligent solutions for monitoring linear axes

The drive mechanisms cannot be monitored by using encoders in servo motors, and by integrating safety-related functions in motor controllers (drive systems), or via external monitoring systems. However, with a linear displacement encoder mounted directly

on the drive, as well as the safety-oriented mounting of a linear scale and measuring head, the axis position can be monitored directly for safety functions up to category 4, PL e.

See pages 19 and 21 for details

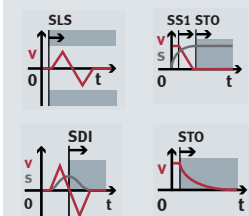

### Sample solutions

How do I implement safety functions with electric drive components?

Festo provides a number of solutions. Descriptions, bills of materials, circuit diagrams, application programs and

Sistema projects allow fast integration into your safety concept – with the appropriate documentation.

→ [www.festo.com/safety](http://www.festo.com/safety)



## Electric Motion Sizing tool



You only need to input a few parameters to describe the applications.



The results are filtered and selected just like on commercial websites.

### Online tool for sizing servo drive packages

Electric Motion Sizing, the new online sizing and simulation tool for electric drives (servo drives and motors = servo drive package) as well as for electromechanical drive solutions (= electro-mechanical servo drive package comprising servo drives and motors as well as mechanics), helps you to find the right electromechanical drive solution for your application quickly and without complications. You only need to enter a few application

parameters, for example mass, stroke/travel distance, cycle time, and Electric Motion Sizing calculates more than 3 million possible product combinations for you. The suggestion you will receive presents the most economical solution from Festo that meets your requirements for the application, as well as additional alternatives. Electric Motion Sizing also provides the parameterisation data for download into the Festo Automation Suite. This simplifies commissioning, too.

### The benefits to you

- User-friendly interface for quick, easy and reliable calculation of the right electromechanical drive solution
- Online tool with free access on the Festo website, with no need to register or to download and install software
- The proposed solution combines the best price and availability
- As a registered user, you can select a solution to run a detailed simulation. This provides you with further information about the solution, for example an analysis of the overshoot behaviour.

→ [www.festo.com/ems](http://www.festo.com/ems)

## Simplified Motion Series Solution Finder



### Your online selection tool:

With the Solution Finder, you can configure the right product for every simple linear or rotary motion by just setting the application parameters and selecting and ordering it in the Online Shop.

→ [www.festo.com/solutionfinder](http://www.festo.com/solutionfinder)

## Commissioning software Festo Automation Suite

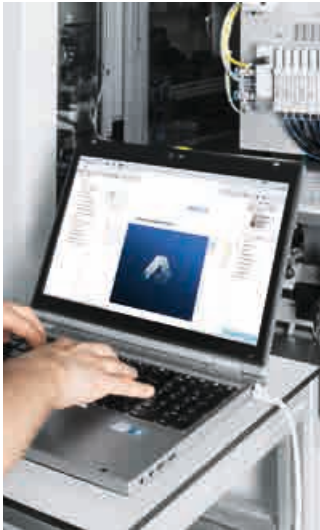

The PC-based software Festo Automation Suite combines the parameterisation, programming and maintenance of Festo components in one program. The entire drive package, from the mechanical system to the controller, can be commissioned. The commissioning software that is available free of charge already contains the basic functionalities of all Festo components.

Plug-ins or add-ons can be installed directly via the program. In addition, device information, manuals and application

descriptions can also be downloaded from the software without having to open a web browser.

### Intelligent connectivity

Using the integrated commissioning wizard, it only takes five steps to reliably configure a fully operational drive system. And with just two clicks, the servo drive CMMT-AS is integrated into the controller program of CPX-E. An optional CODESYS extension enables the motion control and robotics functions of the CPX-E to be programmed.



Free download of the software at [www.festo.com/automationsuite](http://www.festo.com/automationsuite)

## Highlights

- Only five steps to get a drive system up and running
- Customisable thanks to device-specific plug-ins and add-ons
- Integrated controller programming
- Access to device information and manuals directly from the software



The user interface has a uniform look across all functions, whether diagnostic information for valve terminals is requested, or a servo drive is parameterised or programmed in CODESYS.

### 1 Display of component links

List of all components used and hierarchical display of the communication relationships.

### 2 User-orientated design

Add the Festo components by dragging and dropping, then establish the communication connections by intuitively drawing the required lines. The software automatically calculates the basic parameters of the stations in the background.

### 3 Navigation similar to a web browser

Device-specific content is shown on tabs, so that you can conveniently move between the different contents.

### 4 Installing plug-ins

Search for the device you want using the part number or order code, and the Festo Automation Suite will automatically find and install the right plug-in.

## Examples of plug-in features



### **Flexible configuration of the CPX-E terminal**

The individual modules of the CPX-E terminal can be configured and parameterised using a graphical user interface, so

they can be changed, replaced, added or deleted by dragging and dropping them. Module and channel parameters can also be easily set.

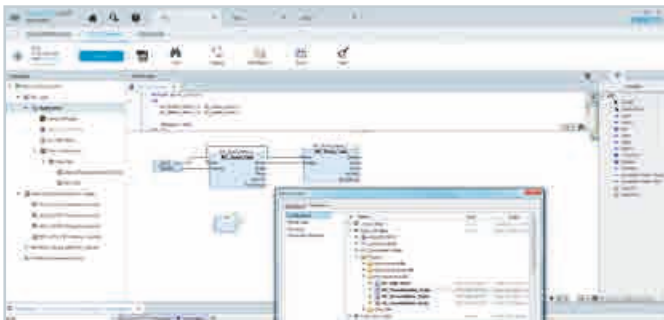

### **Controller programming with CODESYS**

You can download CODESYS as a system add-on. It integrates seamlessly into the user interface of the plug-in and makes the established editors for controller programming

according to IEC 61131-3 available: from simple point-to-point motion and SoftMotion applications with cam disc and CNC functions to robotics applications according to PLCopen Part 4.



### **Extremely easy integration of the drive system**

Where 100 mouse and keyboard operations were once required, two now suffice. After CMMT-AS has been connected to the controller CPX-E by dragging a line, everything else, from integrating the necessary libraries and linking the process

data to transferring important axis parameters, is performed automatically. The drive system is immediately ready for use in the controller program. The result is fewer errors and more time for your main task: creating and commissioning the machine process.

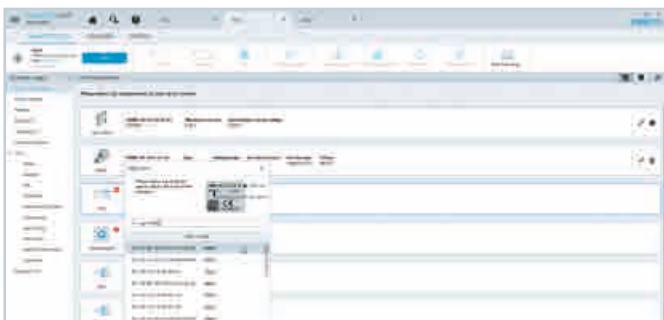

### **Simple and reliable parameterisation**

The clear parameterisation interface allows you to easily select the required Festo mechanical system using the order information, such as the part number. The program takes care of the correct settings as all the technical data – from

the servo drive to the axis – is saved and used to automatically calculate the drive settings. There no longer is a need for complex, manual calculation of the suitable parameter values, which considerably minimises time, effort and sources of error.

## Handling systems and Cartesian robots

The ready-to-install systems provide you with fast and reliable solutions for standard applications that are fully assembled, tested and perfectly coordinated, and include energy chain, connection technology and matching drive package.

**Handling Guide Online: find the right handling system faster than ever before** Configure and order online: [www.festo.com/hgo](http://www.festo.com/hgo)

Configure single-axis systems, linear, planar surface and three-dimensional gantries as well as highly dynamic and compact handling systems quickly and easily with the Handling Guide Online.

- The right handling system, including CAD model and commissioning file, in 20 minutes.
- The engineering effort and the design of the handling system are reduced to just a few minutes
- Very easy and intuitive to use and features structured data prompts
- Shorter time-to-market, because it takes only around 3 weeks from configuration and ordering to delivery and installation.

### New additions to the Handling Guide Online:

Spindle and toothed belt axes ELGC, mini slide EGSC as well as servo drive CMMT and servo motor EMMT.

## 1D handling systems



### Single-axis systems for linear movement

The single-axis system with its high mechanical rigidity and sturdy design is ideal for long, one-dimensional strokes and large loads. It always includes

an energy chain for reliable operation. A matching servo drive package from Festo, as well as many other options, round off the ready-to-install complete system.

## 2D handling systems



### Linear gantry for vertical movements in 2D

High mechanical rigidity makes this linear gantry precise, even with very long strokes of up to 3000 mm in the Y direction. The tubing and cables are routed through energy chains, ensuring outstanding operational and process reliability.



### Highly dynamic linear gantry for maximum dynamic response in limited space

The Cartesian high-speed place robot based on the EXCT offers excellent dynamic response with max. 95 picks/minute, high flexibility and a compact design. It is a slim design with a very compact Z-axis, ideal for flexible handling tasks with free movement in the vertical plane even when installation space is limited.



**Planar surface gantry for horizontal movements in 2D**

With its high mechanical rigidity and sturdy design, this planar surface gantry can be used anywhere, whether with heavy workpieces or high payloads. At the same time, it is extremely precise, even with long strokes.



**Highly dynamic planar surface gantry for maximum dynamic response throughout the installation space**

Thanks to its extremely low moving mass, the gantry with robotic functionality allows up to 100 picks/min and covers the working space of two SCARA robots. It is very compact and flat, and moves almost vibration-free. The working space of the XY planar surface gantry makes handling highly flexible with free planar movement.



**Compact planar surface gantry for maximum working space coverage**

The compact planar surface gantry based on the EXCM shows its advantage, especially when every millimetre counts. It combines outstanding functionality with an extremely compact, flat design and maximum working space coverage.

**3D handling systems**



**Three-dimensional gantry for three-dimensional movements in a space**

The Cartesian robot is ideal for very long strokes of up to 3000 mm in the X direction, even with high loads. The combination of different axis modules means it can be used anywhere, for light to heavy workpieces or a variety of dimensions.



**Highly dynamic three-dimensional gantry for maximum performance in 3D**

With up to 100 picks/min, and being scalable in both X and Y directions, the three-dimensional gantry based on the EXCH is very dynamic as well as extremely compact and flat. The low moving mass allows up to 30% more power and the low centre of gravity ensures low overshoot and better positioning accuracy.



**Compact three-dimensional gantry for high payloads in the smallest of spaces**

The extremely space-saving, compact and flat 3D system is excellent at absorbing high forces and torques, and its length and width are configurable. The solution stands out thanks to its smooth-running characteristics and high positioning precision.



# Productivity

## **Maximum productivity is a question of ambition**

Do you share this attitude? We will be glad to help you achieve this goal – through our four outstanding qualities:

- Security • Efficiency • Simplicity • Competency

We are the engineers of productivity.

Discover new dimensions for your company:

→ [www.festo.com/whfesto](http://www.festo.com/whfesto)