



Contact Us

AUSTRALIA

Headquarters
11/3 Dunlop Court
Bayswater, Victoria 3153
Phone: +61 3 8761 2800

Western Australia
Unit 1/93 President Street
Whelshpool, WA 6106
Phone: +61 8 9353 2537

CANADA

18th Avenue SW
Suites 800 & 900, Calgary
Alberta, T2P 0P7
info@duratray.com

Queensland
Office 804, 10 Market Street
Brisbane, QLD 4000
Phone: +61 7 3221 8332

CHILE

San Francisco 350
Antofagasta
Phone: +56 2 22450411

USA

9100 S Dadeland Blv.
Suite 1500
Miami, FL 3316
Phone: +61 3 8761 2800

Distributors

South Africa

2nd Floor West Tower
Maude Street
Nelson Mandela Sq
Sandton 2196,
Johannesburg
Ph: +27 11 8881 5477

Austria

Kuhn Group
Headquarters
Kuhn Straße 1 5301
Eugendorf
Ph: +43 0622 582 060

Peru

CSRSA
Monte Rosa 270- Of 1204
Urb. Chacarilla del Estanque,
Surco, Lima 33
Ph: +51 17178480

www.duratray.com info@duratray.com



DURATRAY

Customized Design to
Outlast and Outperform
XP Steel Light Dump Body



Custom Features

Ducktail:

Retains the load on ramp grades up to 10 % and higher. This design also maintains correct load distribution within the specifications of the truck OEM.

Steel Liner:

Absorbs impact and protects the truck structure from the sliding wear. Designed to be easily and securely fitted to the dump body.

Side Wall Extension:

Increases volumetric capacity of existing dump bodies.

Rubber: Designed to handle tough impact loads while resisting abrasion. Helps extend the body system's life.

Side Walls: Steel plate or hollow alloy bar for top-rail. Parallel or expanding taper geometry for side-walls. Provides extra reinforcement and preventing material build-up.

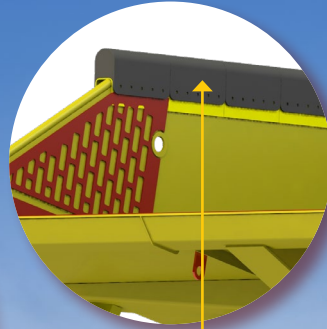
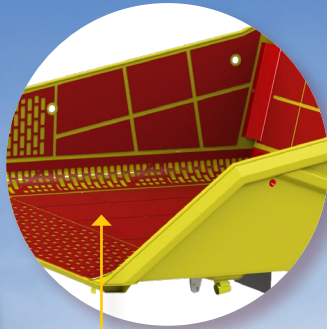
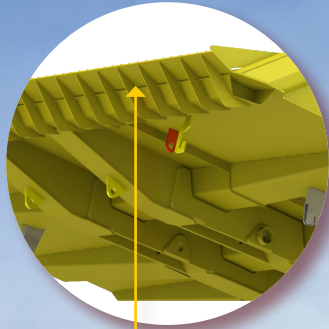

XP Design



- **X**tra **P**ayload
- **X**tra **P**erformance
- **X**tra **P**roductivity

Our Operations



EH3500 - ERG-SSGPO, Kazakhstan



CAT 793 - Severstal, Russia



KOM 930E - BMA, Australia



CAT 793 - Barrick, Argentina



KOM 930E - Codelco, Chile



CAT 793 - Newmont, Australia



CAT 785 - Mantos Copper, Chile



CAT 793 - BMA, Australia



KOM 960E - BHP, Chile



CAT 785 - Ferrexpo, Ukraine



CAT 793 - Severstal, Russia



CAT 797F - AMSA, Chile

