

# ROOBUCK

Australian Edition  
May 2023

## Product Catalogue

For Underground Coal Mines



Roobuck is a leading provider of MineIoT Solutions, Mine Communication Equipment, Cap Lamps, Belt Tags, Safety Signal Lights, and other Explosion-proof Products.

## Accreditations

- Ex Certificates/Approvals: IECEx, MSHA, IA, CNEX
- Ex Quality Standards: ISO/IEC80079-34

## Key Offerings

### Cap Lamps

- Wide range of Intrinsically Safe cordless cap lamps
- Non-Ex cordless cap lamps
- IoT Cap Lamps for tracking and proximity, collision avoidance systems and other safety applications
- Non-Ex corded cap lamp

### Personal Safety Products

- Helmet beacons
- Hi-Vis LED vest
- LED Shoulder Brace

### Industrial Lights

- Runway lights for underground emergency/evacuation
- Intrinsically Safe Strip Lights

### System Products

Together with Technology Partners Roobuck supply:

- WiFi system for tracking, emergency, zone management and communications
- V2P Collision Avoidance System
- Digital Kiosk and Tag Board



## R&D Projects

Digital mine projects supported by Australian Federal Government and NSW State Government, universities and industries, including CRC-P, PSF and ARC Hub projects.

## Global Reach - Exports from Australia to:

- Oceania: New Zealand and Papua New Guinea
- Asia: Mongolia, Uzbekistan, Kazakhstan, UAE, Qatar, Saudi Arabia, Egypt, Indonesia and Singapore
- Africa: Ghana, South Africa, Zimbabwe
- Americas: USA, Canada, Peru, Chile, Colombia

We proudly supply:



IECEX Certified Cordless Cap Lamp: KC4E-Ex	4
Charging Banks and Single Chargers for KC4E-Ex	5

IECEX Certified Cordless Cap Lamp: KC2T-Ex	6
Charging Banks and Single Chargers for KC2T-Ex	7

IECEX Certified Cordless Cap Lamp: KC2M-Ex	8
Charging Banks and Single Chargers for KC2M-Ex	9

Which Cordless Cap Lamp is best for my needs?

Questions - Do you need	KC4E-Ex	KC2T-Ex	KC2M-Ex
An IECEX Certificate?	✓	✓	✓
Bright light for underground operations?	✓		
An angle adjustable cap lamp?	✓		✓
Both focused & spread beam?		✓	
A light for ceiling spotting and distance?	✓		
Low cost product?		✓	✓

Cap Lamp Accessories: RRS, ML, HS, RCB, TG57***	10
---	----

IECEX Certified Helmet Beacon: RHB10G1-Ex	11
---	----

IECEX Certified Strip Light: RIS12*-Ex	12
--	----

IECEX Certified Runway Light: RSS12*RI-Ex	13
---	----

IECEX Battery Powered LED Strip Light: RBS*AR#-Ex	14
---	----

Digital Kiosk and Tag Board	15
-----------------------------	----

## Cordless Cap Lamp

Performance series – for Underground Coal Mines and CHPP

### Features

- 

Three operating modes – Main, High Beam, Auxiliary
- 

Adjustable beam angle to point wherever you look
- 

Lightweight, comfortable and ergonomic
- 

Tough GERMANY enclosure material to withstand rough handling
- 

World's safest and most reliable Panasonic battery
- 

Made from Top Brand, high quality components and parts



### Product Specifications



#### IP Rating - IP67

Submersible in water up to 1m for 30min



#### Illumination

6800 Lx Main Mode  
10000 Lx High-Beam Mode



#### Charging Time

9 h



#### Running Time

14 h Main Mode



#### Ambient Temperature

-20°C ≤ Ta ≤ 40°C



#### Weight

159 g



#### Certifications:

- Certificate #: IECEx TSA 19.0008
- Ex Marking: Ex ia op is I Ma IEC 60079-35-1

#### Standard #:

- IEC 60079-0
- IEC 60079-11
- IEC 60079-28
- IEC 60079-35-1



# Chargers - KC4E-Ex

## CB8E Charging Bank For 8 Cordless Cap Lamps



### Features

- Portable, Wall Mountable, Vehicle Installation
- Locking Plate is optional extra (CB8(E)-LPU)
- Lamp Charging Indicator
- Automatic over-load protection – cuts off that circuit when Cap Lamp battery is fully charged

### Specifications

Input	110 VAC or 12-24 VDC
Output	5.1 VDC/500 mA
Dimensions	33 x 21 x 5.5 cm
Weight	1.1 kg

## CB35E/CB53E - Charging Banks For 35/53 Cordless Cap Lamps

### Features

- Automatic over-load protection – cuts off the circuit when Cap Lamp battery is fully charged
- Label groove
- Padlock bracket
- Lamp Charging Indicator
- Charger Charging Indicator
- Includes wall mounting kit
- 2 x foot pads
- Circuits are easily accessible for servicing

### Specifications

Input	110 VAC	
Output	5.1 VDC/500 mA	
Dimensions	CB35E: 87 x 11 x 56 cm	CB53E: 84 x 13 x 110 cm
Weight	CB35E: 17 kg	CB53E: 31 kg



## Individual Chargers & Accessories

**MCE:** Single Mains Charger - AU, EU, UK, USA    **CBS:** Charging Bank Stand  
**UCE:** Single USB Charger





## Cordless Cap Lamp

Value series – for CHPP and Underground Coal Mines

### Features

- 

Three operating modes – Standard Focus, High-Beam Focus, Spread
- 

Thin design means Cap Lamp fits behind visor and allows it to go up and down
- 

Lightweight, comfortable and ergonomic
- 

Tough GERMAN enclosure material to withstand rough handling
- 

World's safest and most reliable Panasonic battery
- 

Made from Top Brand, high quality components and parts
- 

Comes with free Angle Adjustable Bracket (RCB-A or RCB-U)



### Product Specifications



#### IP Rating - IP67

Submersible in water up to 1m for 30min



#### Illumination

2800 Lx Standard Focus  
5500 Lx High-Beam Focus



#### Charging Time

7 h



#### Running Time

13 h Standard Focus



#### Ambient Temperature

$-20^{\circ} \leq T_a \leq 40^{\circ}$



#### Weight

97 g



#### Certifications:

- Certificate #: IECEx TSA 19.0008
- Ex Marking: Ex ia op is I Ma IEC 60079-35-1

#### Standard #:

- IEC 60079-0
- IEC 60079-11
- IEC 60079-28
- IEC 60079-35-1



## CB8T Charging Bank For 8 Cordless Cap Lamps



### Features

- Portable, Wall Mountable
- Lamp Charging Indicator
- Automatic over-load protection – cuts off that circuit when Cap Lamp battery is fully charged

### Specifications

Input	240 VAC
Output	5.1 VDC/500 mA
Dimensions	33.4 x 18.2 x 6.6 cm
Weight	860 g

## CB28T Charging Bank For 28 Cordless Cap Lamps

### Features

- Wall Mountable
- Optional - Locking Bar
- Lamp Charging Indicator
- Automatic over-load protection – cuts off that circuit when Cap Lamp battery is fully charged
- Space to attach identification label

### Specifications

Input	240 VAC
Output	5.1 VDC/500 mA
Dimensions	84 x 60 x 11.5 cm
Weight	9 kg



## Individual Chargers & Accessories



UCT: Single USB Charger



RCB-A



RCB-U

**RCB-A/U:** Angle Adjustable Brackets

RCB-A slides between the sides of the helmet bracket whereas RCB-U slides between the front & back of the helmet bracket.

## Cordless Cap Lamp

Value series – for CHPP and Underground Coal Mines

### Features



Two operating modes – Main, Low



Well distributed light pattern



Adjustable beam angle to point wherever you look



Lightweight, comfortable and ergonomic



Made from Top Brand, high quality components and parts



### Product Specifications



#### IP Rating - IP67

Submersible in water up to 1m for 30min



#### Illumination

2000 Lx Main Mode



#### Charging Time

7 h



#### Running Time

20 h Main Mode



#### Ambient Temperature

$-20^{\circ}\text{C} \leq T_a \leq 40^{\circ}\text{C}$



#### Weight

119 g



#### Certifications:

- Certificate #: IECEx TSA 19.0008
- Ex Marking: Ex ia op is I Ma IEC 60079-35-1

#### Standard #:

- IEC 60079-0
- IEC 60079-11
- IEC 60079-28





## CB8 Charging Bank For 8 Cordless Cap Lamps



### Features

- Portable, Wall Mountable, Vehicle Installation
- Locking Plate is optional extra (CB8(E)-LPU)
- Cap Charging Indicator
- Automatic over-load protection – cuts off the circuit when Cap Lamp battery is fully charged

### Specifications

Input	240 VAC or 12-24 VDC
Output	5.1 VDC/500 mA
Dimensions	33 x 21 x 6 cm
Weight	1 kg

## CB35/CB53 - Charging Banks For 35/53 Cordless Cap Lamps

### Features

- Automatic over-load protection – cuts off the circuit when Cap Lamp battery is fully charged
- Label groove
- Padlock bracket
- Lamp Charging Indicator
- Charger Charging Indicator
- Includes wall mounting kit

### Specifications

Input	240 VAC	
Output	5.1 VDC/500 mA	
Dimensions	CB35: 87 x 11 x 56 cm	CB53: 84 x 13 x 110 cm
Weight	CB35: 16 kg	CB53: 31 kg



## Individual Chargers & Accessories

**MC:** Single Mains Charger - AU, EU, UK, USA

**VC:** Single Car Charger - Cigarette Lighter

## RRS: Rubber Ring Sheath

Miners now have the option to shroud their Performance Series Cap Lamp with a cost effective, coloured rubber ring, with seven colours to choose from.

It can protect the cap lamp when dropped, bumped or from dripping water. The colour can also be used for group identification of the miners.



## ML: Mining Lanyard

Designed to connect Cordless Cap Lamp to the rear of a Miner's helmet or to the Miner's clothing.

## HS: Head Strap

Anchor your Cap Lamp to your hard hat if it doesn't have a mounting bracket. Uses 4 brim clips.



RCB-A



RCB-U

## RCB: Angle Adjustable Cap Lamp Bracket

Roobuck's patented Cap Lamp Bracket transforms a fixed Cap Lamp into a flexible one. Comes in two versions RCB-A and RCB-U.

RCB-A slides between the sides of the helmet bracket whereas RCB-U slides between the front & back of the helmet bracket.

## TG57: Miner's Hard Hat

Strong but lightweight A.B.S construction for durability and robustness with a rolled gutter around the brim for water control.

Features adjustable 6-point web harness with universal slots to accept 25~30mm insert attachments.

White hard hat is in stock but colour options are available upon request.



## Intrinsically Safe Helmet Beacon Light

For Underground Coal Mines and Petrochemical Applications

### Features



Green, Red, Blue, White & Amber



Low running cost



Easily attached to helmet



Fully sealed for the best ingress protection



Coin battery



### Product Specifications



#### IP Rating - IP65

Dustproof and direct spray proof



#### Operating Mode

Steady, Flash, Blink



#### Running Time

200 h in Flashing Mode



#### Ambient Temperature

$-20^{\circ}\text{C} \leq T_a \leq 40^{\circ}\text{C}$



#### Weight

45 g



#### Certifications:

- Certificate #: IECEx ITA 15.0006
- Ex Marking: Ex ia I Ma or Ex ia IIB T4 Ga

#### Standard #:

- IEC 60079-0
- IEC 60079-11







## Intrinsically Safe Strip Light for Area Illumination For Underground Coal Mines, Petrochemical Environments and Underground Hardrock Mines

The RIS12\*-Ex strip light is Intrinsically Safe and designed for area illumination in underground coal mines, petrochemical environments and underground hardrock mines. It is easy to mount and can be attached to machinery, walls or other objects. It is lightweight and can be carried if you need portable illumination.

It is powered by an external 12VDC I.S. power supply. There is a 2-wire lead at an end of the strip light to connect to a junction box or I.S. power supply directly.



Feature	RIS12S-Ex	RIS12M-Ex	RIS12L-Ex	Installation Accessories
 Power	1.4 W	2.8 W	4.2 W	<ul style="list-style-type: none"> <li>• Clips for wall mounting</li> <li>• Tags</li> <li>• Sticky tabs</li> <li>• Brackets</li> </ul> All models come with 1 metre of cable to connect into your intrinsically safe power supply
 Number of LEDs	42	84	126	
 Length of Light	0.8 m	1.5 m	2.2 m	
 Weight	200 g	300 g	400 g	

### Product Specifications



**IP Rating - IP65**  
Dustproof and direct spray proof



**Ambient Temperature**  
-20~40 degrees

- Certifications:**
- Certificate #: IECEx TSA 22.0010
  - Ex Marking: Ex ia op is I Ma or Ex ia op is IIB T4 Gb

- Standard #:**
- ICE 60079-0 :2017
  - IEC 60079-11 :2011
  - IEC60079:28:2015



## Runway Light

### For Underground Coal Mines and Petrochemical Environments

A Runway Light is powered by an external 12VDC Power supply. There are 2-wire lead at an end of the strip light to connect to a junction box or I.S. power supply directly. LEDs can be steady or flashing in sequence to generate a flowing effect to show a direction.

#### Features



Direction identification



Fire-resistant



High ingress protection



Easy to install



#### Product Specifications



**IP Rating - IP65**

Dustproof and direct spray proof



**Power Supply**

12 VDC



**Power**

20 W



**Length**

20 m



**LED Colour**

Red or Green



**Ambient Temperature**

$-20^{\circ}\text{C} \leq T_a \leq 40^{\circ}\text{C}$

#### Models

- Steady Style: RSS12SR1
- Flashing Style: RSS12FR1

Default colour is red. Other colours are optional

#### Certifications:

- Certificate #: IECEx TSA 22.0008
- Ex Marking: Ex ia op is I Ma / Ex ib op is IIB T4 Gb

#### Standard #:

- IEC 60079-0:2017
- IEC 60079-11:2011
- IEC 60079-28:2015



## Intrinsically Safe Battery Powered LED Strip Light

### For Petrochemical Environments

This strip light is a chain of several LED Soft Bars. There are different types of LED Soft Bars with different numbers of LEDs. A LED Soft Bar is consisting of a FPCB fully sealed in a transparent shrink tube. All LED Soft Bars are connected using cables, connectors and jointing boards to form a complete Battery Strip Light. The Battery Box connects to the LED strip chain either directly or through a connector to supply power.

#### Applications

- LED Workwear design
- Portable safety product design
- Sign enhancement
- Equipment visualisation
- Site safety

#### Features



Zone 0 environment



Flexible construction



Portable and stationary

Indoor or outdoor use

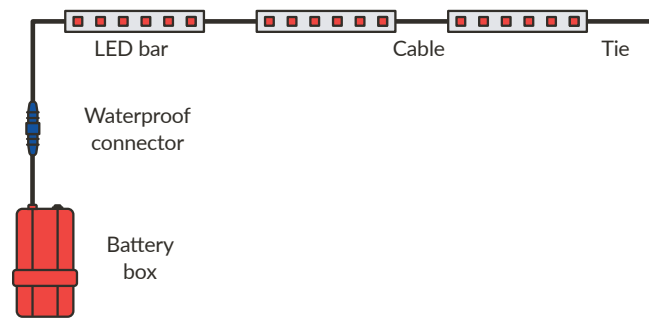

This product is certified with great flexibility and is made to the customers requirements. Everything can be customised, including:

- the amount of LED bars and their positions,
- the amount of LEDs in each bar, and
- the length of each cable.

Default LED color: Red, other colours optional  
Batteries: 2xAA

Other LED colours and 3AH rechargeable Lithium battery are available, subject to price variations and extended delivery times.

Running time (T) is decided by the total number of LEDs (N) and operating mode. T in hours in steady mode can be estimated using the following formula. In a flashing mode, T is doubled.

$$T = 300/N \leq 16$$

#### Attention: Product Developers

This Strip Light is an OEM product. You are welcome to use it to design your own intrinsically safe products with our engineering support.

#### Certifications:

- Certificate #: IECEx TSA 22.0007X
- Ex Marking: Ex ia op is I Ma / Ex ia op is IIB T3 Ga

#### Standard #:

- ICE 60079-0:2017
- IEC 60079-11:2011
- IEC 60079-28:2015

### Product Specifications



#### IP Rating - IP65

Dustproof and direct spray proof



#### Operating Mode

Steady, Slow Flashing, Fast Flashing



#### Ambient Temperature

$-20^{\circ} \leq T_a \leq 40^{\circ}$



#### Weight

90 g - battery box



## Location, Safety & Asset Management Miner and Cap Lamp registration, shift sign-in/sign-out, miner Cap Lamp pairing and inventory record

The Digital Kiosk and Tag Board form a comprehensible solution to record:

- Who is tagged in
- What Section of the mine they are working
- Which Kiosk they used to sign in
- What Department they are assigned to
- What devices are assigned to the person. Examples are cap lamp, self-rescuers, belt tags, gas monitors
- Nearest AP to identify personnel's location. This feature is only available if using Roobuck's IoT Cap Lamps or Belt Tags

### Digital Kiosk

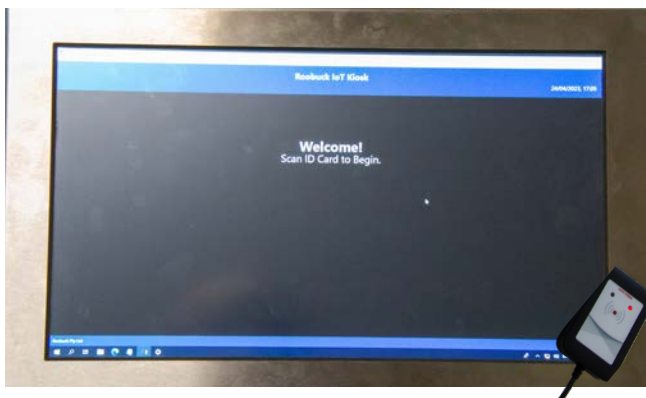

- Touch Screen for easy use
- Rugged for use in harsh conditions
- Multiple kiosks located at all entry and exit points
- Works with both IoT devices and equipment with NFC tags attached
- Miners sign on using NFC enabled ID card
- Miners scan all NFC and IoT devices and pair with their name
- Data can be exported for analysis and productivity reporting.

### Electronic Tag Board

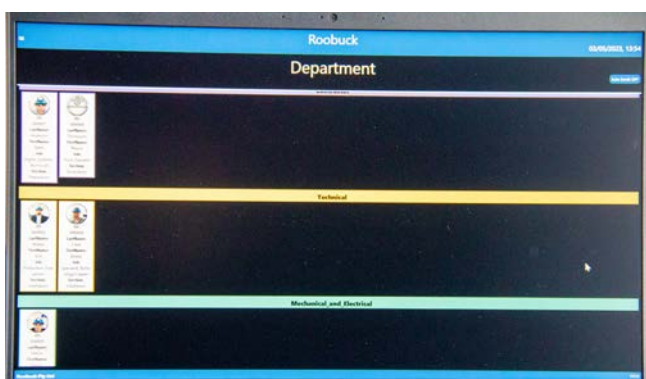

- Electronic Tag Boards have multiple views of all personnel tagged in. Personnel and their associated assets can be viewed by Section, Department, Kiosk and nearest AP location
- Multiple large screens strategically located underground can be viewed by all personnel
- Operational Supervisors & Safety Managers can access views on their PC screens
- Locations with time stamps updated on Electronic Tag Board for users paired with IoT devices
- Search for personnel and their associated information

The Digital Kiosk can be integrated into your preferred PPE solution upon request.

**This project is ready for pre-commercial trials. Please contact Roobuck for details.**

# Roobuck Pty Limited

ABN 68 130 073 451

## Headquarters:

Suite 6, 20 West Street  
Brookvale, NSW 2100  
Australia

Phone: + 61 2 9938 1550

Fax: +61 2 9939 8532

Email: [info@roobuck.com.au](mailto:info@roobuck.com.au)

Web: [roobuck.com.au](http://roobuck.com.au)

## Other Australian Catalogues

Product Catalogue for Underground Hardrock  
Mines and Tunnels

Product Catalogue for Surface Operations  
and Industrial Applications

Product Catalogue IECEX Group II for  
Petrochemical Environments

We proudly supply:

**RioTinto**



**BHP**



**THIESS**



Transport  
for NSW