

A Higher Level of Performance

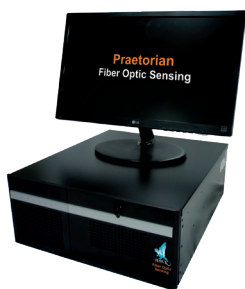

## **Praetorian** Fiber Optic Sensing Conveyor Idler Monitoring



For more information, please visit >  
[www.hawkmeasurement.com](http://www.hawkmeasurement.com)



# Praetorian Conveyor Health Monitoring System



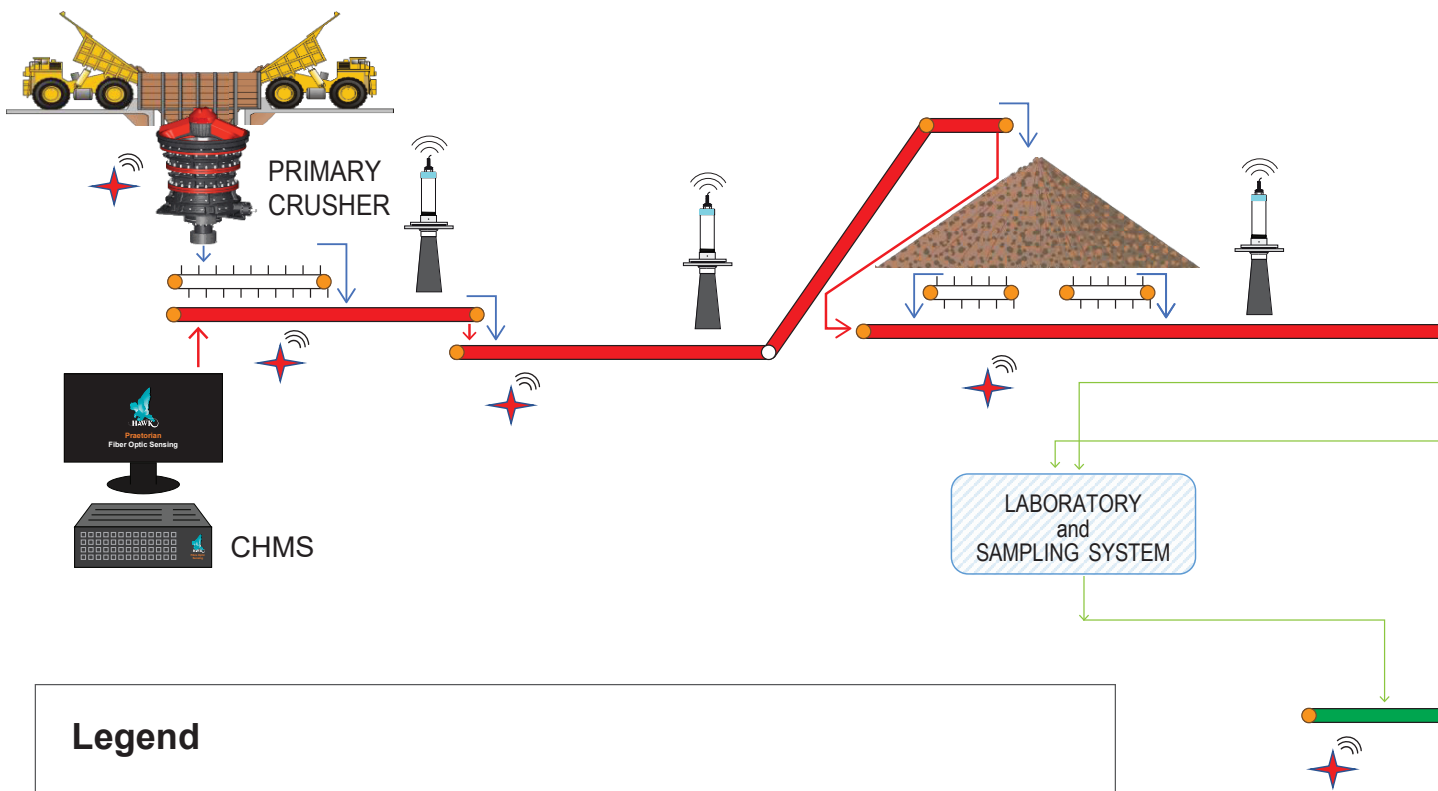

The Praetorian Conveyor Health Monitoring System (CHMS) is a plant & site wide single solution for detecting when critical parts of the idler are beginning to fail.

The early detection warnings allow operators to control down time and avoid catastrophic costly unplanned shutdowns.

HAWK's Praetorian Fiber Optic Sensing detects abnormalities in conveyor idler performance that other technologies cannot.

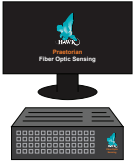

### Legend

	<p><b>Praetorian CHMS Processor</b></p> <hr style="border: 2px solid red; width: 100%;"/>		<p><b>3-Axis Accelerometer Vibrational Wireless Condition Monitor / Gateway</b></p>
	<p><b>Praetorian CHMS Processor</b></p> <hr style="border: 2px solid green; width: 100%;"/>		<p><b>IoT Enabled Sultan Acoustic Wave Sensor</b></p>

# Praetorian Fiber Optic Sensing

Conveyor Idler Monitoring

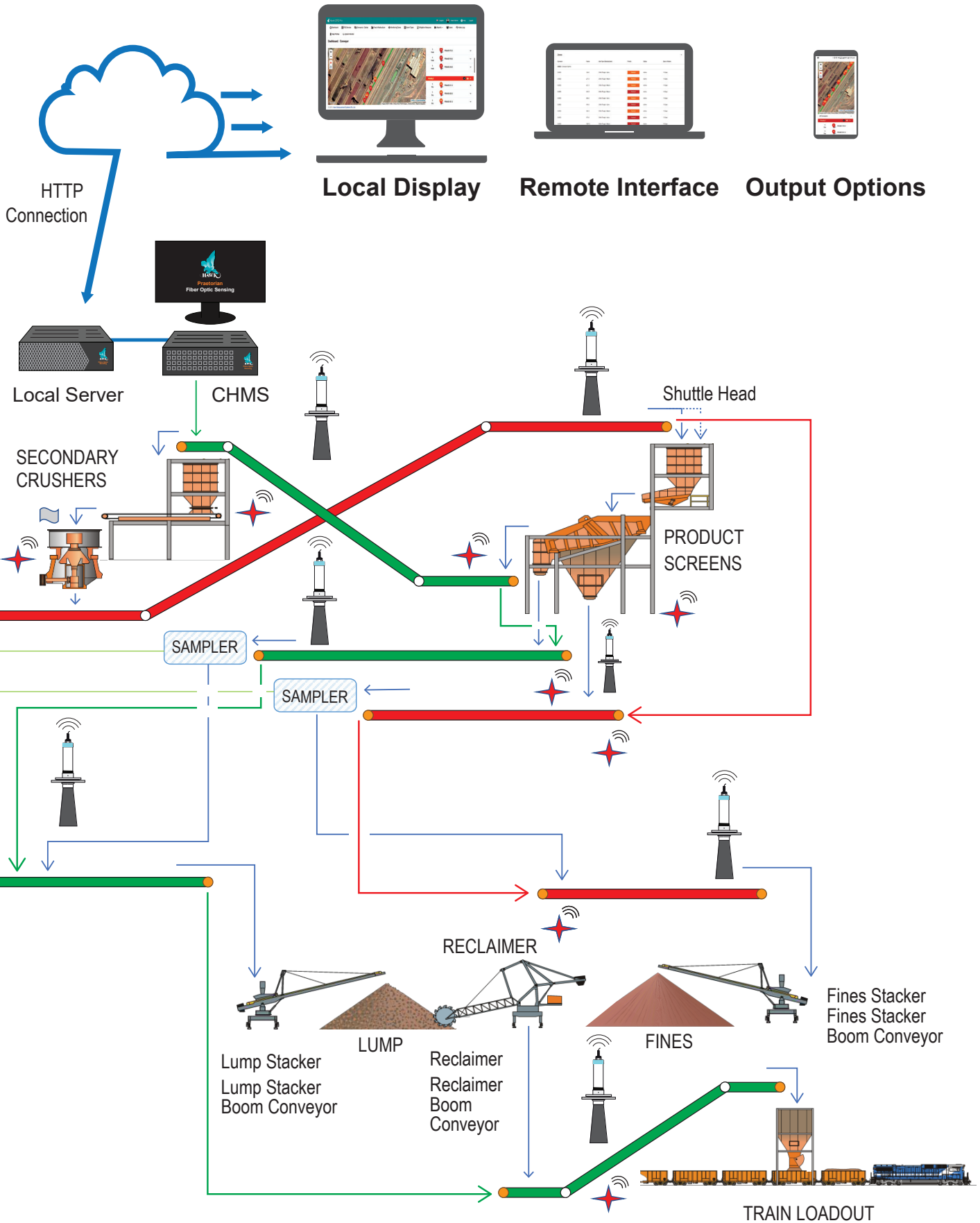

# **Praetorian** Fiber Optic Sensing for Conveyor Idler Monitoring

**Eliminate Unscheduled Conveyor Downtime  
Real-Time Preventative Roller Failure Detection**





### Introduction: The Problem

The mechanical nature of conveyors make them highly prone to wear and tear which can lead to failure of components and cause failures that can shut down the entire conveyor. Since conveyors are often the main form of locomotion for raw and saleable material within a plant; it follows that when a conveyor goes down so too does the profitability of an operation.

Traditional conveyor inspection activities (commonly called “Belt Walks”) have two main problems:

1. The first issue is that these manual inspections are intermittent in nature due to inspections being done once per shift, per day or in some instances even less frequently. This can lead to rollers moving from good condition to a catastrophic failure condition between two inspections.
2. The second issue is that the inspections are subjective rather than objective due to the inclusion of human error, one inspector might list a roller as “All clear” whilst another may mark the roller as failed and in need of replacement. In either case an undesirable result has occurred, either:
  - A roller is changed out prematurely
  - A failed roller or a roller prone to failure has been left in operation

A solution to this problem must therefore address these two issues by providing a technology that monitors continuously (rather than intermittently) and provides discreet consistent objective measurement (rather than subjective or opinion based), analysis and output of conveyor idlers that are in failure mode or at risk of failure.

### Praetorian: The Solution

The Praetorian Conveyor Health Monitoring System (CHMS) provides a simple and reliable way to monitor the condition each moving part of the conveyor and give an easy to understand running condition. Praetorian requires no infield resources such as power and communications are requires no additional data storage or data processing IT assets. Without the need for additional power or communications to be installed in the field Praetorian can be installed and commissioned for a fraction of the price traditional instruments and removes the requirement for ongoing periodic conveyor inspection.

The Praetorian Conveyor Health Monitoring System CHMS consists of an interrogator and processor unit mounted in indoor climate controlled environment which are then connected to a fibre optic cable that is run out to the application (potentially kilometers away). The Interrogator uses the fiber optic cable as a sensing element capable of detecting vibration, temperature and strain along the total fiber length in a fully distributed manner. In this way each piece of the fibre optic cable can be thought of as an independent, multi-variable sensor.

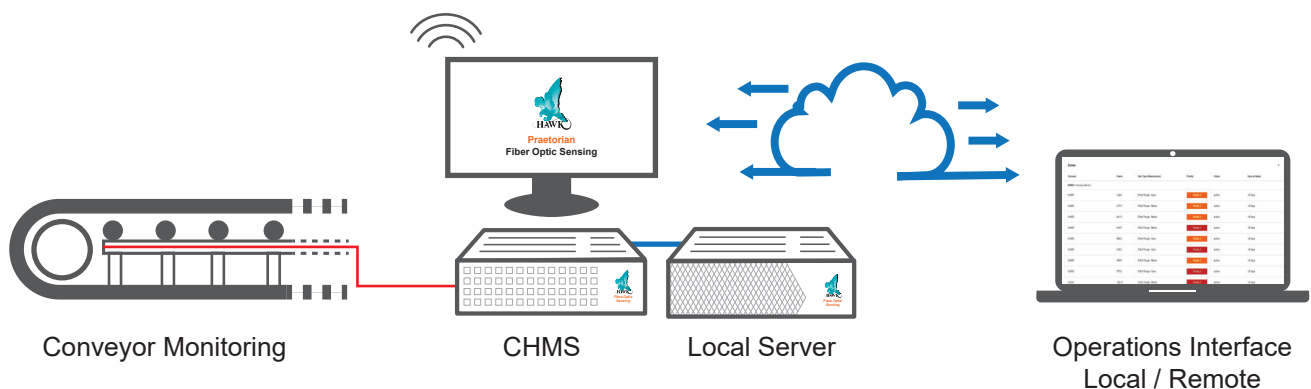



### Application Proven

HAWK has shown the simplicity of installation and minimal time to fully implement a system to be operationally correct and immediately useful. The HAWK FOS can detect all vibrational variation within the fiber. These vibration variation will occur for monitoring all failure modes of an installed fiber on carry roller or return roller. HAWK has the most advanced signal production and signal pattern recognition due to the speed and certainty of its in-house designed hardware and software.

The Praetorian can be integrated with existing site infrastructure via Ethernet communications (typically TCP/IP) and provide alarm status to that existing infrastructure displaying individual frames in an easy to understand traffic light (Red, Amber and Green) condition indication system. Alternatively Praetorian can be implemented into the CFD Pro software package to display historic and current alarms, generate custom reports, and provide SMS and Email alerts functionality. Alarms are displayed)

Infinitely adaptable, a single Praetorian interrogator can be configured to monitor a single large conveyor or be routed around a plant to cover multiple conveyors at once. With a total fiber length of 25km per Interrogator it is possible for an entire plant's worth of conveyors can be covered by a single Praetorian system.

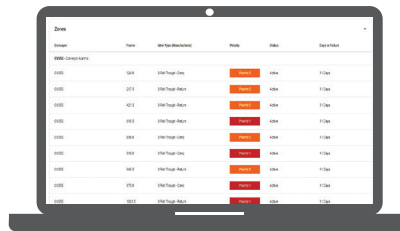
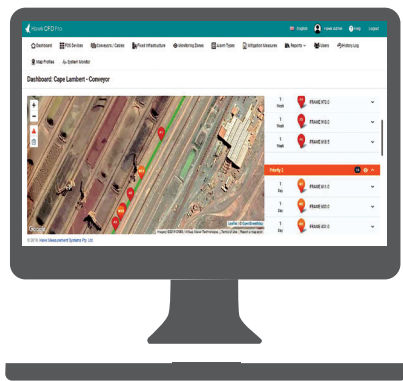



### CFD Software Interface, Conveyor Alerts at Your Fingertips

**Hawk CFD Pro** English Hawk Admin Help Logout

Dashboard FOS Devices Conveyors / Cables Fixed Infrastructure Monitoring Zones Alarm Types Mitigation Measures Reports Users History Log

Map Profiles System Monitor

**Dashboard: Conveyor**

Frequency	Alert Type	Frame ID
1 Week	A4	FRAME 973.0
1 Week	A5	FRAME 918.0
1 Week	A6	FRAME 618.5
<b>Priority 2</b> 14		
1 Day	W1	FRAME 611.0
1 Day	W2	FRAME 600.0
1 Day	W3	FRAME 451.0

### Principle of Operation

The Praetorian system Interrogator unit is connected to one end of a fiber optic cable which is attached to the conveyor belts static structure. The Interrogator produces rapidly pulsed laser light set at a precise frequency that excites the fiber and causes it to be responsive to physical changes around it. Some of this light is reflected back (backscattered) to the light source where the Interrogator records and analyses looking for changes to its physical effects in the application.

### Time of Flight

Locations of events are able to be accurately determined by a method called time of flight. Similar to radar, sonar and ultrasonic instruments, the amount of time from sending the laser pulse to receiving a return signal is recorded.

### Vibration Detection

Light that is reflected back to the interrogator in the form of backscatter gets diffracted by the internal properties of the fibre optic core itself, in the case of vibration detection Rayleigh backscatter is used to determine both the intensity and frequency of vibration at each point along the fibre.

In practice the Rayleigh backscatter responds to physical vibrations imparted on the fiber by disturbances in the conveyor belts normal vibrations. Traditionally the challenge of determining conveyor fault though sound has been to be able to remove the significant noise and vibration that are part of the normal running condition of the conveyor.

HAWK's signal analysis software allows Praetorian to determine changes in ongoing idler noise and determine based on that noise which signals are trending towards that of a failure condition. Praetorian uses longitudinal monitoring of each roller to track condition over time and uses a process of signal characterisation to build an accurate depiction of roller frequency. Praetorian then reports the locations and condition of worn idlers to operators.



### Primary Areas of Applications

---

#### Installation locations:

- Coal mines, hazardous area suitable (no infield electronics)
- Hard rock mines
- Quarries
- Buildings
- Unmanned material handling facilities
- Processing plant conveyors

#### Possible applications:

- Overland conveyors
- Building fire detection
- Conveyor fire detection
- Remote or rural conveyors

### Benefits

---

Using the Praetorian Conveyor Health Monitoring System (CHMS) as a preventative maintenance and asset protection tool provides an organization with the following benefits to its built materials handling operations:

- Removes inspection personnel from the line walking
- Increases asset availability percentage
- Extension of roller effective lifespan
- Automates drive pulley monitoring
- Significantly reduces conveyor downtime
- Reduces change out frequency and duration
- Low cost per idler to monitor
- 24/7 automatic monitoring
- IOT enabled and ready
- Big data - made simple, analytics at your fingertips
- Whole organization ready, operator to C-Level user levels
- Compatible with other sensors for material and blockage detection
- Compatible with new or existing plan control systems
- Roller failure alerts via email or SMS
- Automatic roller fault reporting
- EMF immune, lightning resistant
- Quick ROI turnaround (hours-days)
- Fire detection system option available
- Suitable for hazardous environments (no power in field)
- Reduces personnel exposure to dust, noise, vehicle usage, environmental heat risk and HSE risk sources
- Works on all fixed idler conveyor types
- Multiple conveyors from 1 system
- Mechanically and environmentally resistant

### Features

---

The Praetorian Conveyor health monitoring system features a parallel dual channel design build around the concept of monitoring conveyors from both sides. This allows for not only more accurate prediction of failure but also for indication of failure being present on the right or the left aspect of the conveyor, this design feature has been include based on customer feedback indicating manual identification of which specific roller in a frame is faulty during operation can be challenging.

Praetorian can be adapted to all types of static roller conveyors, this includes traditional through conveyors, Garland Roller Conveyors and Cable Conveyors, HAWK have developed different types of mounting arrangements to suit. Praetorian is designed to have a series of self diagnostic routines that monitor the operating condition of both the interrogator and filed optics. Broken or degraded cables are instantly detected and reported allowing for rapid, low cost repair.





## Other Applications

Distributed sensing technology has opened up a wide range of automation application options that were previously impossible or unfeasible using traditional instruments, Praetorian is capable of being installed with additional Distributed Temperature Sensing (DTS) and Distributed Strain Sensing (DSS) modules allowing for a multitude of sensing applications, these include but are not limited to:

- Perimeter Intrusion Detection System (PIDS) Security
- Pipeline Leak Detection System (LDS)
- High Voltage Power Transmission or Data Cable Monitoring Systems (CMS)
- Over-Conveyor Fire Detection (Metallurgical or Thermal Coal Conveyors)
- Infrastructure Strain and Stress Monitoring
- Rail Infrastructure Monitoring
- Open Cut Slope Monitoring
- Tailings Dam Wall Monitoring



### Field Proven Technology

The Praetorian Conveyor Health Monitoring System has been used successfully at a number of sites for faulty idler detection and prevention. Utilizing both the Praetorian hardware and the CFD Pro Software these customers have been able to change their operations from a reactive model to a predictive maintenance model where idlers are changed out prior to failure.

With easy installation design methodology a Conveyor Health Monitoring System is targeted at being installed during Scheduled site shutdowns (typically annually or biannually). Installation can be conducted quickly and without disrupting other site works, field optics take a number of hours to complete and instrumentation commissioning is generally completed at a rate of 1km per hour. Linkages to existing infrastructure (such as SCADA or DCS) are confirmed as part of handover.

Once installed and calibrated the system automatically detects, locates and reports on failed or failing idlers either to the existing control system or to the operators directly via the CFD Pro server.

Idlers that have slow failure modes such as bearing or shell wear degrade slowly, as they degrade their signal behavior changes over time and their failure parameter increases until the time of replacement.



*Idler Shell Collapse*



*Idler Shell Collapse*

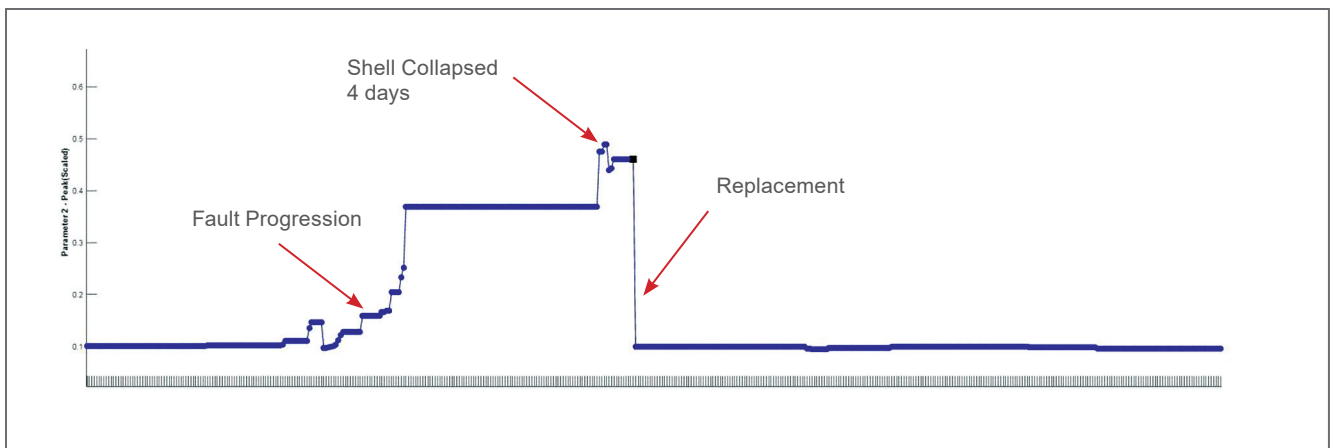

*Idler Shell Collapse – Fault Progression Graph*

# Praetorian Fiber Optic Sensing

## Conveyor Idler Monitoring



In other cases failure of idlers can occur rapidly due to external events or sudden internal failures. These failures are typically referred to as “catastrophic failures” as the idler is often torn apart by the collapse event. HAWK has found that these catastrophic events are not instantiations and occur over a period of time prior to the catastrophic failure but that this time period is measured in hours rather than days.

Praetorian is configured to send emergency alerts direct to on-site operator contact points at the point of detection such that a suitable planned response can be arranged prior to the failure event.

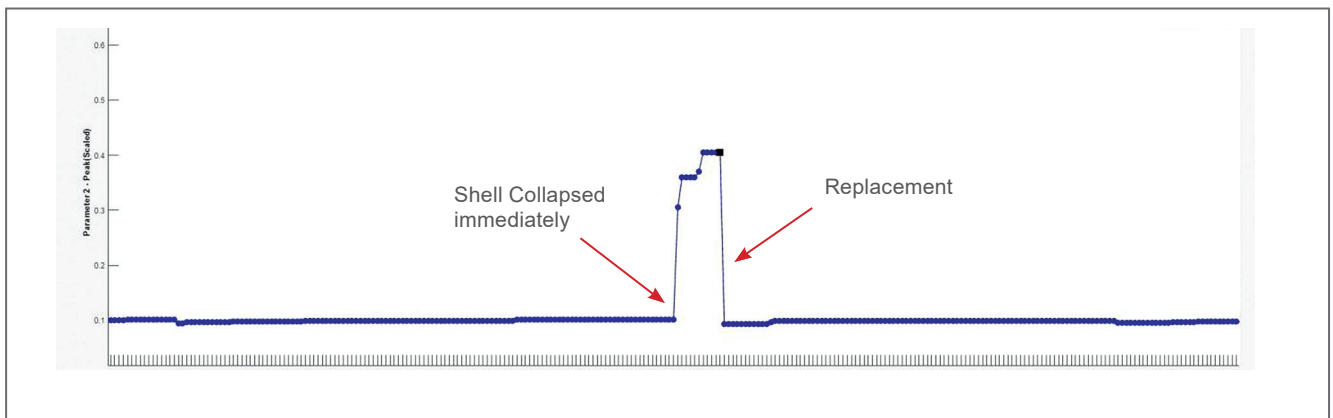

*Idler Shell Collapse – Fault Progression Graph*



### Technical Specifications

Category	Parameter	Description
General	Sensing element	Fiber Optic Sensing cable
	Number of channels	1 or 2
	Interrogator operating temperature	0 to -40°C (32 to 104°F)
	Interrogator storage temperature	-20 to -60°C (-4 to 140°F)
	Interrogator operating humidity	10-85% @ 40°C (104°F) non-condensing
	Interrogator storage humidity	10-95% @ 40°C (104°F) non-condensing
	Dimensions (rack enclosure)	4RU, 19" Rack, 600mm minimum depth
	Dimensions (physical)	430 x 177 x 479mm (16.93 x 5.9 x 18.85 inches)
	Weight	25kg (55 lbs)
	Power supply	110-240VAC (50-60Hz), 24VDC
	Power consumption	<200W
DAS Performance	Sensing range - conveyors	Up to 25kms (16 miles) per channel
	Spatial resolution	250 or 500mm (10" or 20")
	Frequency response	1Hz-120kHz (range dependant)
	Dynamic range	50dB
	Temperature sensing range (cable)	-30°C to 200°C (-22°F to 392°F) (special options for temps up to 800°C (1472°F) and down to -200°C (-328°F) available)
Technical	Light source	Laser (Infra red) class 1M
	Laser wave length	1550.12nm (nanometers)
	Laser stability	±5pm (picometers)
	Acquisition rate	400MHz
	Processor acquisition rate	64Bit (ultra high speed)
	Operating system	Linux
	Output	Modbus ethernet TCP/IP (standard), relay, USB, SCADA or user specified
	Remote interfacing	Ethernet and 3G/4G enabled
	Processor architecture	Field Programmable Gate Array (FPGA)
	Data storage (removable)	2x 2TB HDD (removable)
	Data storage (internal)	128GB solid state drive

#### Hawk Measurement Systems (Head Office)

15 - 17 Maurice Court, Nunawading VIC 3131, AUSTRALIA  
 Phone: +61 3 9873 4750  
 Fax: +61 3 9873 4538  
 info@hawk.com.au

#### Hawk Measurement (America)

5010 Gateway Drive, Medina, OH 44256, USA  
 Phone: +1 888 HAWKLEVEL (1-888-429-5538) /  
 Phone: +1 978 304 3000 / +1 877-356-5463  
 Fax: +1 978 304 1462 / +1 330-331-7172  
 info@hawkmeasurement.com

For more information and global representatives: [www.hawkmeasurement.com](http://www.hawkmeasurement.com)

Additional product warranty and application guarantees upon request.  
 Technical data subject to change without notice.