

March 30 - 31, 2025 | Boston Convention & Exhibition Center | Boston, MA

TABLE OF CONTENTS

IN-LINE/LINEAR BOOTH	2
PERIMETER BOOTH	3
PENINSULA BOOTH	4
ISLAND BOOTH	5
HANGING SIGNS & TRUSS SYSTEMS	5
DOUBLE-DECKER BOOTHS	6
ADDITIONAL REGULATIONS	6-7

THE CUBIC CONTENT RULE:

The New England Restaurant & Bar Show has implemented the Cubic Content Rule, which allows exhibitors to make maximum use of their booth space. Under the Cubic Content Rule, each exhibitor may build right up to the front of the booth space, up to the maximum allowable height. The height varies according to the booth type, as shown in the table and sketches below.

Please be sure to pass along these regulations to your display company, if you have one, before the construction of your booth begins. It will save your company time and money if you build your booth to be in compliance from the beginning. Large fees can accrue if you are required to alter any unapproved designs onsite.

Note that Show Management does not give variances to the Exhibit Design Regulations unless a Booth Variance form is submitted and approved in advance of the show. It is expected that each exhibitor reviews these regulations and is in full compliance. If your company fails to comply you will be required to make all necessary changes to comply, and participation at future shows may be in jeopardy.

IMPORTANT: For Island and Peninsula booths, designs not approved by Show Management in advance of New England Restaurant & Bar Show may not be allowed to be installed on the Show Floor

	IN-LINE/LINEAR	PERIMETER	PENINSULA	ISLAND
Maximum Height Permitted:	8' FROM FLOOR TO HIGHEST POINT IN BOOTH <small>(see pg. 2 for approved space)</small>	12' FROM FLOOR TO HIGHEST POINT IN BOOTH <small>(see pg. 3 for approved space)</small>	20' FROM FLOOR TO HIGHEST POINT IN BOOTH <small>(see pg. 4 for approved space)</small>	20' FROM FLOOR TO HIGHEST POINT IN BOOTH
Required To Submit Floor Plan?	NO	NO	YES	YES
Permitted To Hang Sign?	NO	NO	YES - (UP TO 20FT)	YES - (UP TO 20FT)

IMPORTANT: Hanging signs must comply with the display regulations. This includes all hanging or suspended material such as banners, etc. The top of the sign (or other material) may not exceed the height limitation specific to your type of booth. Hanging signs & graphics should be set back five feet (5') from adjacent booths.

IN-LINE/LINEAR BOOTH

DEFINITION

Exhibit consisting of one or more standard 10'x10' booth units in a straight line, bounded by 1 or 2 aisles.

HEIGHT

Exhibit fixtures, components, products and identification signs will be permitted to a maximum height of 8ft (2.44m).

DEPTH

The Show follows the Cubic Content Rule, which allows exhibitors to make maximum use of their booth space. Each exhibitor may build right up to the front of the booth space, up to the maximum allowable height (8ft).

PRODUCT DISPLAY

Equipment, product, or machinery when displayed to demonstrate or simulate industrial application are exempt from the foregoing height limits, but are restricted by ceiling height, as well as building and safety codes. In consideration of this exemption the excess height must be a result of the actual height of the equipment from the exhibit hall floor to the top of the equipment. Additionally, no graphics, signage, logos, etc. may be posted on equipment above the height limit for your particular booth type.

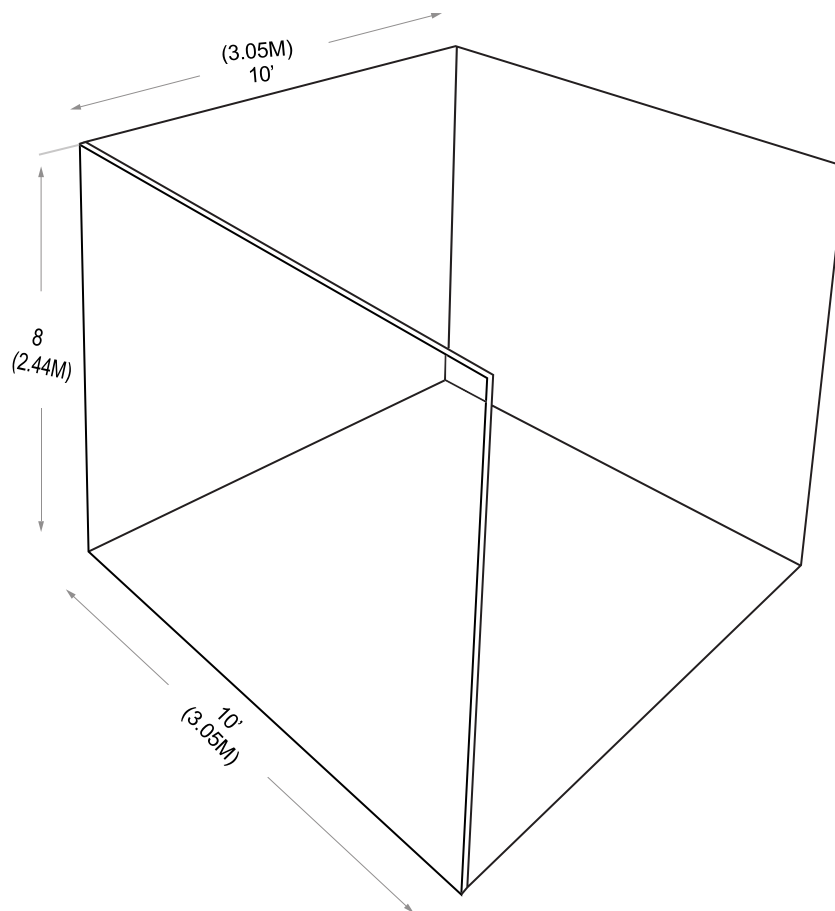

PERIMETER BOOTH

DEFINITION

Inline/Linear booth located on the outer perimeter wall of the exhibit floor.

HEIGHT

Exhibit fixtures, components, products and identification signs will be permitted to a maximum height of 12ft (3.66m).

DEPTH

The Show follows the Cubic Content Rule, which allows exhibitors to make maximum use of their booth space. Each exhibitor may build right up to the front of the booth space, up to the maximum allowable height (12ft).

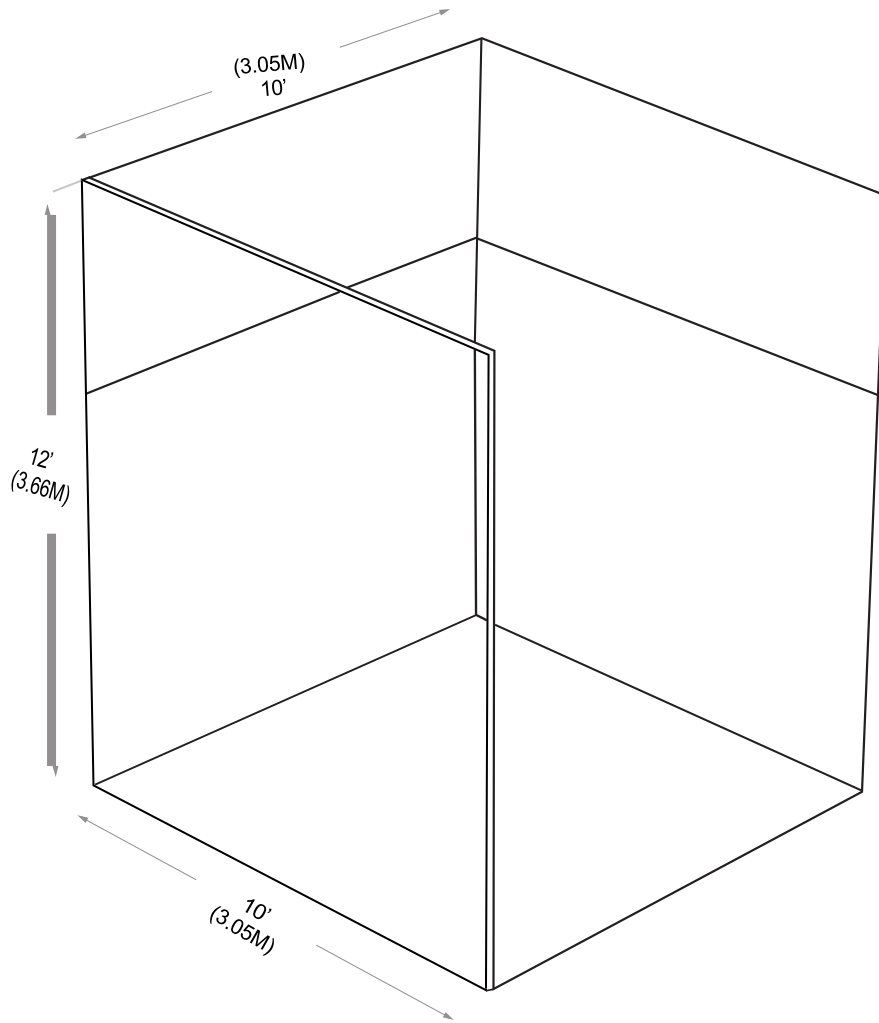

PENINSULA BOOTH

DEFINITION

Bounded by 3 aisles and is 20'x20' or larger.

NOTE: Check your Confirmation Contract to confirm your booth type before designing your exhibit. Not all booths with three open sides are considered Peninsula Booths.

HEIGHT

Exhibit fixtures, components, products and identification signs will be permitted to a maximum height of 20ft (6.1m). Hanging signs must be set at least 5' from backline, and at a max height of 20' from the exhibit floor to the top of the sign.

DEPTH

The Show follows the Cubic Content Rule, which allows exhibitors to make maximum use of their booth space. Each exhibitor may build right up to the front of the booth space, up to the maximum allowable height (20ft).

APPROVAL

Booth designs not approved by Show Management in advance of the Show may not be allowed to be installed on the show floor.

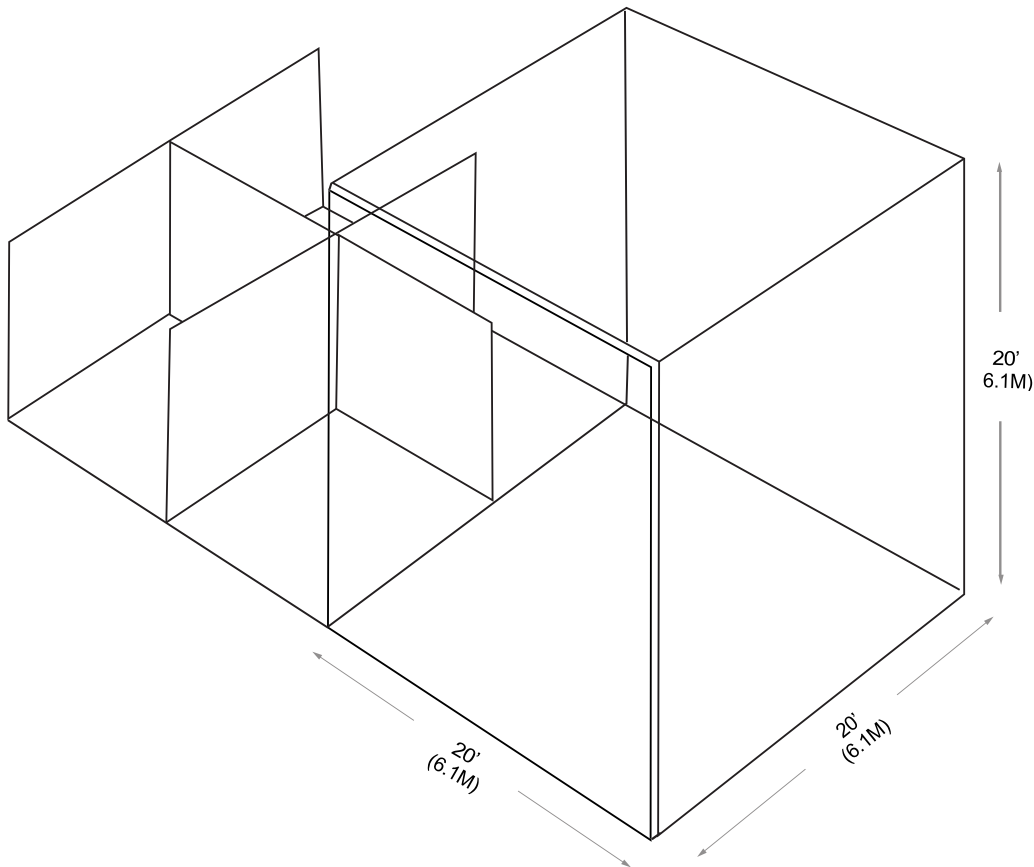

ISLAND BOOTH

DEFINITION

Bounded by 4 aisles and is 20'x20' or larger.

HEIGHT

Exhibit fixtures, components, products and identification signs will be permitted to a maximum height of 20ft (6.1m) from the floor to the highest point in the booth. Hanging signs must be set at a max height of 20' from the exhibit floor to the top of the sign.

APPROVAL

Booth designs not approved by Show Management in advance of the Show may not be allowed to be installed on the show floor.

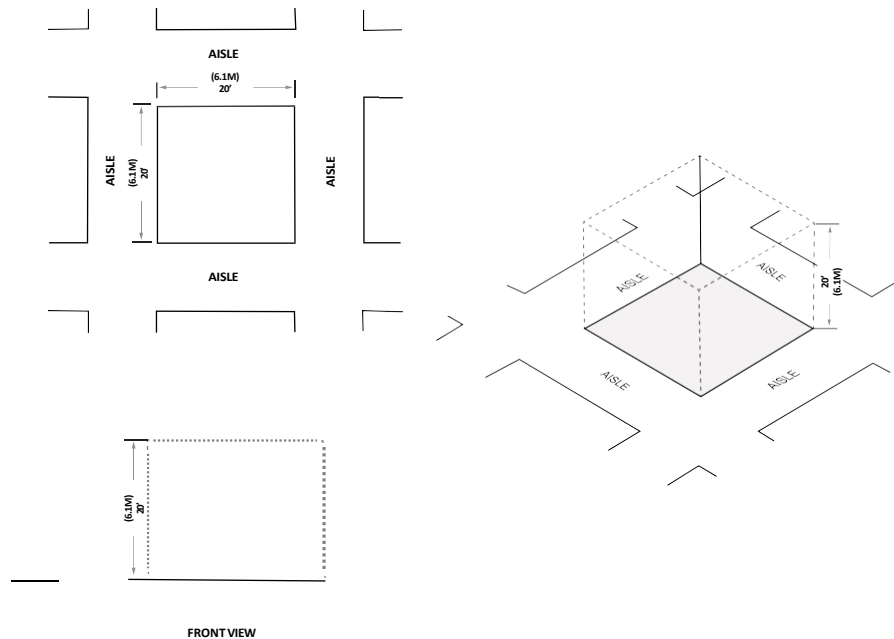

HANGING SIGNS

DEFINITION

Any exhibit component, including but not limited to signs and machinery, that are hung from or attached to ceilings, exhibit structures, or building supports for the purpose of displaying graphics or identification. Hanging signs will be permitted in Island and Peninsula Booths only.

HEIGHT

Hanging identification signs and graphics will be permitted to a maximum height of 20ft (6.1m) from the floor to the highest point in the booth in an Island or Peninsula Booth, provided written approval is received from Show Management.

TRUSS SYSTEMS

DEFINITION

A truss system is a support structure made up on metal bars and is typically used specifically for lighting purposes, with light directed into the booth space and which contains NO identification or signage. Truss may exceed the height limits in Peninsula and Island booths IF approved by Show Management at least thirty (30) days prior to the opening day of the Show.

Exhibit Design Regulations

(Continued)

DOUBLE-DECKER EXHIBITS

DEFINITION

A Double-Decker exhibit is a two-story structure where the second story is functional and may be occupied by people. Double-Decker exhibits will be permitted in Island and Peninsula Booths only.

HEIGHT

Double-Decker exhibits may not exceed 20ft (6.1m) in height, including all signage and structures. Exhibitors using Double-Decker exhibits must abide by all regulations defined for their respective booth type.

STRUCTURAL INTEGRITY

Drawings are required for all Double-Decker exhibits to include a signature or stamp of a reviewing structural engineer indicating the structure design is properly engineered for its proposed use, and a signature of an authorized official of the exhibit building company indicating the structure is built in compliance with the details and specifications set forth on the drawings. If the second story of a Double-Decker exhibit is functional, signs must be posted indicating the maximum number of people the structure will accommodate safely.

APPROVAL

All double-decker exhibits are subject to applicable state and city building codes and are subject to inspection by state/city officials and the Massachusetts Convention Center Authority. Smoke detectors must be installed on the first floor of the exhibit and every subsequent enclosed level. Exhibit fire sprinkler systems are required of any exhibit that has a roof, or any other covering, that would impede the effective use of the facilities sprinkler system. A 20 lbs. BC fire extinguisher must be visible on every level of the exhibit.

ADDITIONAL DESIGN REGULATIONS

DEMONSTRATION EQUIPMENT:

Equipment, product or machinery when displayed to demonstrate or simulate industrial application are exempt from the foregoing height limits, but are restricted by ceiling height, as well as building and safety codes. In consideration of this exemption the excess height must be a result of the actual height of the equipment from the exhibit hall floor to the top of the equipment. Additionally, no graphics, signage, logos, etc. may be posted on equipment above the height limit for your particular booth type.

BOOTH WALLS MUST BE FINISHED:

All back walls and sidewalls must be finished or draped, no loose wire or any obstruction may be seen or Show Management, at the exhibitor's expense, will drape them. See-through back walls or displays that do not cover the back wall entirely will not suffice.

NO GRAPHICS ON NEIGHBORS' SIDE:

The back-side of walls – the common border facing a neighboring booth – must be devoid of copy, logos or other graphics, so as not to be an eyesore to neighboring exhibitors.

NO NAILS OR SCREWS:

Nothing may be taped, posted, tacked, nailed or screwed to columns, walls, floors or other parts of the building. Show Management will remedy any damage or defacement caused by infractions of this rule at the exhibitor's expense.

SOUND LEVELS:

Exhibits which include the operation of musical instruments, radios, sound and/or public address systems or any noisemaking machines must be conducted or arranged so that the noise resulting from the demonstration will not disturb or disrupt adjacent Exhibitors and their patrons, nor cause the aisles to become blocked. Loudspeakers must be positioned to direct sound toward the center of the exhibit booth or display area; NOT pointed toward the aisles. The 80/80 sound Rule: Any sound which consistently exceeds 80 decibels measured at the edge of an Exhibitor's booth, is clearly identifiable more than 80 feet from that booth, or is, in the opinion of Show Management, objectionable or interfering with neighboring exhibits is considered in violation of the Show's Terms and Conditions.

HANDOUTS:

Distribution of literature, samples or other materials outside your contracted exhibit space is strictly prohibited. The distribution of any samples, literature or other materials from a non-exhibiting company (one without a contract to exhibit) is expressly prohibited. No literature may be distributed outside of your booth.

GOOD TASTE AND THE RIGHTS OF OTHERS:

Show Management may require any exhibitor to make changes in his/her exhibit if, in Show Management's opinion, the exhibit does not conform to the prevailing standards of good taste or interferes with the rights of other exhibitors.

STORAGE:

Fire regulations prohibit storing product, literature, empty packing containers or packing materials behind back drape. In most cases, however, exhibitors may store a limited supply of literature or product appropriately within the booth area, so long as these items do not impeded access to utility services, create a safety problem or look unsightly.

STRUCTURAL INTEGRITY

All exhibit fixtures and components exceeding 12ft (3.66m) in height must have drawings available for review by Show Management, the installation and dismantling contractor, the exhibitor and governmental authority during the time the exhibit is being erected, exhibited and dismantled at the Show site.

All exhibit displays should be designed and erected in a manner that will withstand normal contact or vibration caused by neighboring exhibitors, hall laborers, or installation/dismantling equipment, such as fork lifts. Displays should also be able to withstand moderate wind effects that may occur in the exhibit hall when freight doors are open. Refer to local building codes that regulate temporary structures.

Exhibitors should ensure that any display fixtures such as tables, racks, or shelves are designed and installed properly to support the product or marketing materials to be displayed.

FLAMMABLE & TOXIC MATERIALS

All materials used in display construction or decorating must be made of fire retardant materials and be certified as flame retardant. Samples should also be available for testing. Materials that cannot be treated to meet the requirements should not be used. A flame-proofing certificate should be available for inspection. Exhibitors should be aware of local regulations regarding fire/safety and environment which must be adhered to. All open flames must be shut off after the Show closes each day. Exhibitors should dispose of any waste products they generate during the exhibition in accordance with guidelines established by the Environmental Protection Agency and the facility.

VIDEO PROJECTION

Exhibitors may use video projection in their own booth but not into public space or neighboring space. The height of the video projector may not exceed the maximum height for the booth space.

UTILITY PORTS

If your booth is not equipped with a utility port, access will be drawn from a neighboring booth, or if necessary, dropped from overhead. Conversely, utilities may be drawn from your booth for a neighboring booth even if you have not ordered electrical or plumbing connections.

EARLY TEAR-DOWN PROHIBITED

Attendees visiting the Show on the last day expect and deserve a full, robust line-up of exhibitors. Early tear-down, packing and/or leaving your booth unmanned is not permitted or approved for any exhibitor. If your company breaks down or leaves early, your participation in future shows will be in jeopardy.

Adapted from IAEE the Guidelines for Display Rules & Regulations, 2019