

As the world leader in designing, manufacturing and distributing construction materials, Saint-Gobain is committed to helping build a more sustainable future. Together our companies can provide innovative, high performing solutions for a wide variety of construction and infrastructure projects, helping create more energy efficient and comfortable living and working environments. Saint-Gobain construction products cover a wide spectrum, from architectural glass and thermal and acoustic insulation systems to building product distribution, plasterboard products and infrastructure solutions.

In the UK and Ireland, some of the best known and respected companies in the construction materials sector are part of the group, including British Gypsum, Isover, Glass Solutions, Weber, Ecophon, Jewson and Saint-Gobain PAM UK.

Saint-Gobain PAM UK is the primary supplier of ductile and cast iron products to the UK's key utilities, telecoms, highways, civil engineering, construction and housing sectors, including:

- Cast iron soil and drain and rainwater systems.
- Ductile iron water and sewer pipes, fittings, valves and couplings and adaptors.
- Ductile iron access covers, gratings and surface box.

Together with its international parent company, Saint-Gobain PAM, Saint-Gobain PAM UK has supplied products to countless major construction projects across the world. With access to worldwide technical excellence and a large portfolio of products, Saint-Gobain PAM UK is able to combine the benefits of a global presence with the ability to develop and offer products to satisfy local requirements. With the Saint-Gobain PAM UK and PAM range of products you are assured of the highest standards of quality, innovation and technical expertise at all times.



# Contents

## Introduction



## Section 1 Access Covers



## Section 2 Gully Grates



## Section 3 Channel Gratings



## Section 4 Kerb Drainage



## Section 5 Surface Boxes



## Section 6 Installation



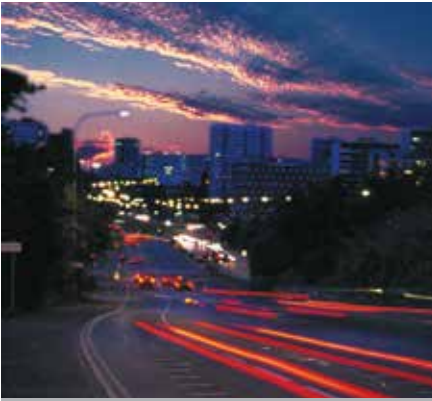

# Ductile iron access cover and grating range overview

Saint-Gobain PAM UK manufactures over 300 products to suit a wide variety of applications and uses. Produced at our foundry in Melton Mowbray, our access covers and gratings are all third party accredited and kitemarked to ensure full compliance with all European, British and industry standards.

## Access Covers

Our access covers are the preferred choice of the utilities, telecoms and highways sectors. We manufacture a comprehensive range for both carriageway and pedestrian areas which are engineered to meet the needs of all stakeholders with particular emphasis on durability, operator and road user safety, ease of use and security. Available in over 60 different clear opening sizes and in load classifications from F900 to B125 we have a solution for many applications.

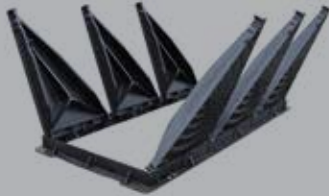

## Gully Gratings

Growth in traffic speed and density coupled with ever changing climatic conditions is placing greater emphasis of the need to install high performance, problem free drainage solutions. We combine in depth market knowledge with enhanced features that aid in the reduction of future maintenance and improved water clearing capacity. Ranges available from F900 to B125 load classifications and in a wide choice of clear openings and waterway areas to cope with even the highest volumes of surface water run off for all road types

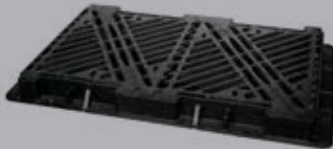

## Kerb Drainage

Research led by Nottingham University into how ironwork interacts with the road construction determined that critical features such as the seating contact areas the thickness of the frame and flanges and controlled manufacturing tolerances when designed, engineered and manufactured correctly, combine to ensure and enhance optimum performance.

Saint-Gobain PAM UK has used the results of this research to develop the Load Transfer System (LTS). This system has become a standard feature across our core ranges giving peace of mind that products are stronger, more resilient and even more durable.

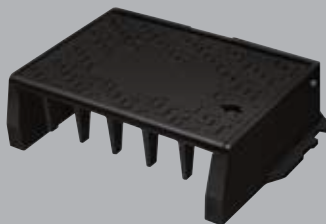



# Ductile iron access cover and grating range overview

## Channel Gratings

Suitable for linear drainage systems our channel gratings are available in E600 to C250 load classifications and in various widths. Each have bearer bars available to aid installation when using in conjunction with concrete channels formed on site.

## Surface Boxes

Designed to offer fast and easy access to below ground services all of our surface boxes are compliant with BS5834 Surface boxes, guards and underground chambers for the purposes of utilities. The Warrior range has long been the solution of choice within the utilities sector providing over 20 years of trouble free performance with in excess of 2.8 million installed in the UK so far.

## Technical Advisory Service

As the UK's leading manufacturer of ductile iron access covers and gratings we offer a comprehensive technical support service. This service is provided free of charge and includes advice on all elements of product design, manufacture, specification and installation. Our technical team can be contacted at [technical.covers.uk.pam@saint-gobain.com](mailto:technical.covers.uk.pam@saint-gobain.com) or by telephone +44 (0) 1664 814014





Our bespoke testing facility ensures our products full compliance to the requirements of BS EN124 and BS5834.



## Made in the UK

The Saint-Gobain PAM UK foundry near Melton Mowbray in Leicestershire remains at the forefront of the design and manufacturing of high-performance ductile iron access cover and grating solutions for the Infrastructure, Civil Engineering, Water & Utilities Sectors.

In the manufacture of our products, Saint-Gobain PAM UK is a major recycler of ferrous scrap and wherever possible sources other raw materials that are themselves the waste or by-products of other industrial processes. By doing this we minimise our impact on the environment and usage of the world's finite resources. Products manufactured at Holwell contain 98% recycled materials and are themselves 100% recyclable.

### System

**BS EN ISO 9001**

**Quality management systems**

kitemark licence number FM12908.

**BS EN ISO 14001**

**Environmental management systems**

kitemark licence number EMS83973.

**OHSAS 18001**

**Health & safety management systems**

kitemark licence number OHS 570684.

### Sustainability

**CEMARS**

**Certified emissions measurement and reduction scheme**

Certificate number 2016053J. CEMARS certification demonstrates the Company's commitment to measuring, managing and reducing greenhouse gas emissions in a robust and credible way.

**BES6001**

**Responsible sourcing of construction materials**

kitemark licence number BES613621.

### Product

**Access Covers and gratings**

**BE EN124 2015 Pt 1 & 2**

**Gully tops and manhole tops for vehicular and pedestrian areas**

kitemark licence number KM30794.

**Surface Boxes**

**BS5834 Pt 2**

**Specification for small surface boxes**

kitemark licence number KM07199.

**BS5834 Pt 3**

**Specification for large surface boxes**

kitemark licence number KM14164.

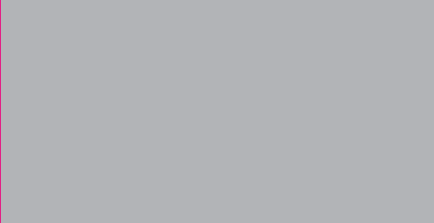

# Creating value through collaboration

We routinely collaborate across industry sectors, which often leads to the development of solutions and best practice that when combined deliver tangible value for our customers. We define the needs of the sector and its stakeholders and jointly create solutions based on the customer's desired outcomes.

## Case study 1 **Kent County Council**

**Reducing whole life costs through the adoption of best practice.**

The importance of collaboration across all client stakeholders was key in helping Kent County Council understand and overcome issues of failing ironwork on a busy commuter route resulting in higher than budgeted costs. By adopting a holistic approach to product specification, selection and installation, Kent County Council has seen tangible savings through a reduction in replacement and reinstatement costs by more than 60%.

## Case study 2 **Mway Communications Ltd**

**Contributing to Highways England's efficiency targets.**

Developments in off-site solutions such as the Integrated Access Chamber Cover slab have allowed the M60 and M3 Smart Motorway Projects to make significant improvements to every aspect of the works by applying LEAN techniques to the traditional construction process. Benefits include saving approximately 9,600 manual handling activities, 6,000 miles of plant movements, 4,800m of timber shuttering and 6,400 man hours.

## Case study 3 **Surrey County Council**

**Improving road safety by reducing the risk of flooding.**

Combining shared expertise and an innovative approach to design has resulted in the development of a solution to prevent flooding. The large capacity "super gully" provides a system that, once installed, is able to cope with high surface water flow and have a much greater silt capacity than traditional gully construction. These features will enable improved water dispersal, eliminating flooding and reducing accidents throughout the year.

## Case study 4 **Transport for London**

**Improving cyclist and pedestrian safety.**

Working with Transport for London, Saint-Gobain PAM UK has developed a new cycle-friendly drainage grating to improve cycle and pedestrian safety. It features a grid mesh design that is safer for cyclists, but still ensures that surface water is efficiently drained through its large waterway area. Ivan Bennet, Senior Industrial Product Designer for Transport for London, stated "A number of modern road bikes have very narrow wheels and a risk assessment identified a possible hazard where wheels could get stuck in drainage gratings. Saint-Gobain PAM UK worked with us to develop a solution which is now being installed.

Saint-Gobain PAM UK is continuing to engage stakeholders from across various industry sectors: these case studies are just a few examples of how we have added value. If you would like to understand more about how this approach can benefit your organisation, please get in contact.

# Capabilities & Services

Saint-PAM UK has invested in a comprehensive range of support tools and services to help tailor solutions to meet our customer's needs and as an aid to advise them of what the appropriate product specification, identification, selection, and installation of our products should be.



The largest choice of badging options either standard or bespoke to aid asset identification and traceability



Innovative solutions to help promote right first time installation practices, reducing costs and saving time.



The development of a wide range of products that include anti-theft and anti-vandalism features to protect valuable assets, ranging from simple but effective locking options through to LPCB third-party certified security solutions



A series of training aids and CPD presentations have been created to help inform our customers, focusing on key elements such as standards and specification.



We undertake extensive research into product performance and efficiency to ensure durability and the lowest whole life costs.

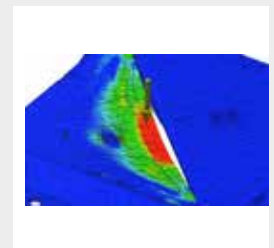

We routinely utilise the latest technology in the engineering, design and manufacturing of our products.

For further information relating to any of our extensive product range or services please visit [www.saint-gobain-pam.co.uk](http://www.saint-gobain-pam.co.uk) or contact us on +44 (0) 1159 305 000



# Frame levelling and installation system

As traffic speed and volume increases, greater emphasis is being placed on the smooth running of the national and local road network. To help ensure this, it is important that the need to reinstate ironwork is avoided but this can only be achieved if the work practices, materials, solutions and the specification that govern them evolve and adapt.

Re-work caused by poor workmanship or through a lack of understanding of the correct use of materials is estimated to cost c. £200m per year, a cost that can be reduced significantly if simple rules are followed.

As part of its research and development programme, Saint-Gobain PAM UK focused on arriving at a solution that would promote a right first time approach to installation. Its key aim was to provide a system to reduce the time taken while enabling efficient use of bedding and reinstatement materials and that will ultimately reduce the whole life cost.

The result of this is the development of the Install Plus Frame Levelling System which is engineered to help eliminate the issues faced when installing carriageway access covers and gratings. There are a number of key elements that combine to guarantee the durability and long term performance of the installation:

## Depth of the bedding material

This is assured by four nylon inserts which are located on the underside of the frame flange and pre-set to allow for a minimum and consistent depth of bedding mortar of 15mm.



## Enveloping of the flange

Using a flowable bedding material creates a homogenous layer with the material below the flange. Using the bedding indicator on the top of the insert this ensures the mortar is to the recommended minimum depth of 20mm above the flange.



## Frame height, level and gradient

It is important that the top of the frame is flush with the surrounding surface. To accommodate changes in gradient and camber, further adjustment can be made by rotating four nylon bolts clockwise to raise the frame to the required finished level. The bolts have a range of adjustment of 15mm to 50mm.



Install Plus is available across a variety of our access covers and gratings products.

For further information please contact us on our Access Covers and Gratings Technical Enquiries and Assistance hotline on **+44 (0) 1664 814014** or email **technical.covers.uk.pam@saint-gobain.com**

For detailed information on how to use the Install Plus system please refer to the Installation section of the guide.



# Product specification





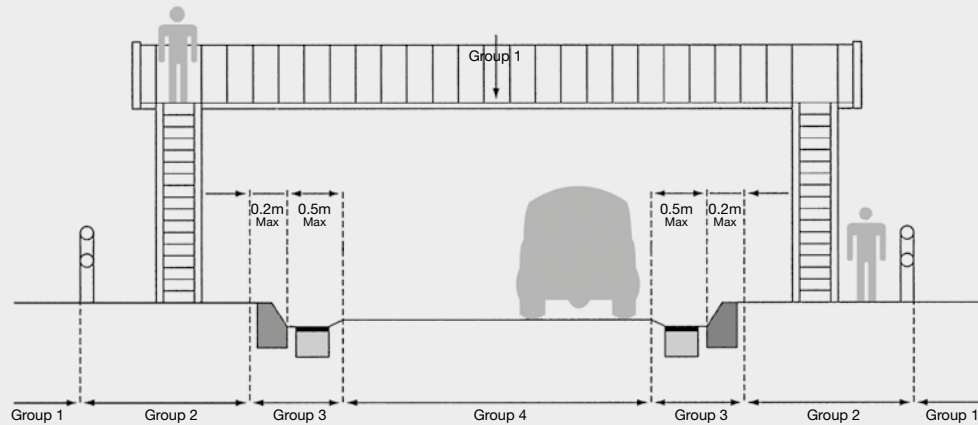







Ductile iron access covers and gratings used in the UK should, as a minimum comply with the requirements of Parts 1 & 2 of the European Standard BE EN124 2015. Products designed to this standard are grouped into load classifications dependent on their intended application. It is the responsibility of the specifier to ensure that the correct product is specified. Where in doubt a heavier load classification should be used.

Clause 5 BS EN 124



For advice and assistance on any aspect of product specification in relation to product or industry standards please contact our **Technical Enquiry helpline +44 (0) 1664 814014**

To help with product specification and selection we have shown the load classification and BS EN124 group for each of our products. For example below is our Aqua-Max D400 gully grating, through the use of easy to use icons we can show that it falls within Group 4 and has a load capability of D400.

BS EN124 Group	Application	BS EN124 Load Classification	BS EN 124 test load
	Areas imposing high wheel loads such as aircraft pavements, container port and docksides		900kN
	Areas of fast moving traffic or where high wheel loads are present such as container port and docksides		600kN
	Areas subjected to continuous heavy traffic		400kN
	For applications that extend $\leq 500$ mm from the kerb line into the carriageway		250kN
	Areas such as car parks or where occasional vehicular access is required		125kN
	Areas that are only accessible by pedestrians or cyclists		15kN

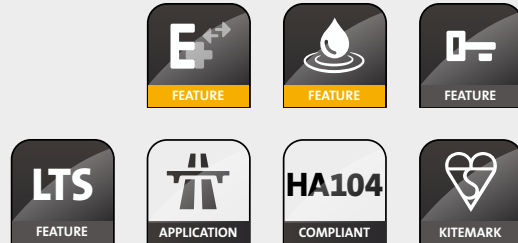

Access covers, gully gratings and surface boxes are often specified by their clear opening dimensions (AxB) and frame depth (E) as indicated on these drawing examples. Additional reference can also be made to the total overall size or overbase (C x D).

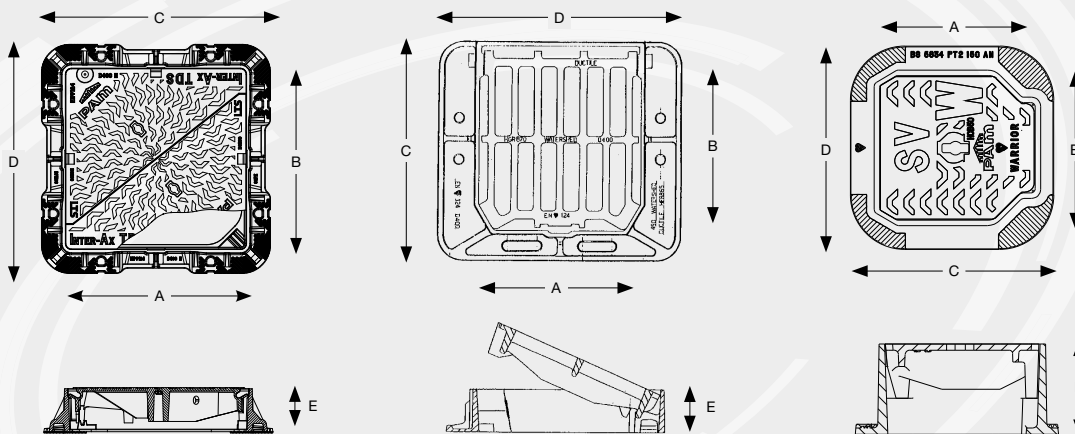

At a glance

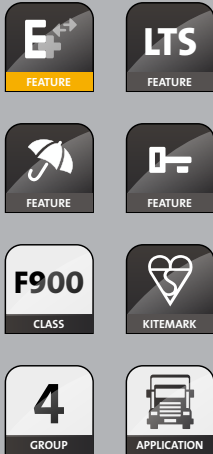

The gold and silver indicators identify the added level of benefit each product provides.



(For access covers only)

Includes a feature(s) that offers improved skid and slip resistance.

The PSRV values have been independently verified in accordance with the requirements and methodology stated within BS 9124.

# At a glance



The product displays a level of performance and includes features compliant with the requirements of Highways England advice note HA104.



Suitable for use in domestic areas with occasional light vehicular access.



Suitable for use in car parks and areas of slow-moving access to cars and light commercial vehicles.



Suitable for use in conditions of heavy traffic, eg. main city streets and roads.



Suitable for use where continuous high levels of fast-moving heavy traffic are present.



Suitable for areas subject to slow-moving heavy loadings, eg. industrial premises.



Suitable for areas subject to very heavy wheel loads such as aircraft pavements and container areas.



Includes the Load Transfer System (LTS) feature for optimum installation and durability.



Includes an infiltration feature which drastically reduces surface water ingress.



Includes integrated anti-fall protection.

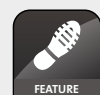

(For gully gratings only)  
Includes a specially designed grating for use in pedestrian areas.



Indicates products that are suitable as one person operable as they include ergonomically positive opening features.

Gold indicates a fully ergonomic opening system. Silver indicates a semi-ergonomic inspection system.



Includes a security feature to deter unauthorised access ranging from high security (gold) to lesser locking levels.



(For gully gratings only)  
Indicates the level of absorption efficiency of a grating ranging from high (gold) to lesser levels.



(For access covers only)  
Includes a feature which reduces egress of unwanted odour ranging from high resistance (gold) to lesser levels.