

SureTap[®]

Hot Tapping Machines



Issue 7 - Sep 2023

[STATSGROUP.COM](https://www.statsgroup.com)



STATS BISEP

SUPPLY LIFTS

SV-40-600-04

SureTap[®] Hot Tapping Machines

The SureTap range of proprietary tapping machines provide performance and reliability to meet all your critical, high pressure tapping requirements. Designed and built to incorporate industry leading features, the SureTap range incorporates a dual sealing configuration allowing taps to be performed safely on a wide range of pipeline materials and mediums, including use with sour (H₂S) products. A positive retention pilot drill system has been incorporated to ensure robust securing and recovery of the cut pipeline coupon.

All SureTap machines have the capability for onshore, topsides or subsea operation and are fully compatible with industry standard tapping equipment including the deploying and recovery of completion plugs.

Materials of Construction

The SureTap machines are manufactured from high quality materials to European or North American standards. All components used to contain pressurised process fluids are manufactured from pressure vessel grade materials (to ASTM or EN standards), impact tested at sub-zero temperatures and resistant to sulphide stress cracking (SSC).

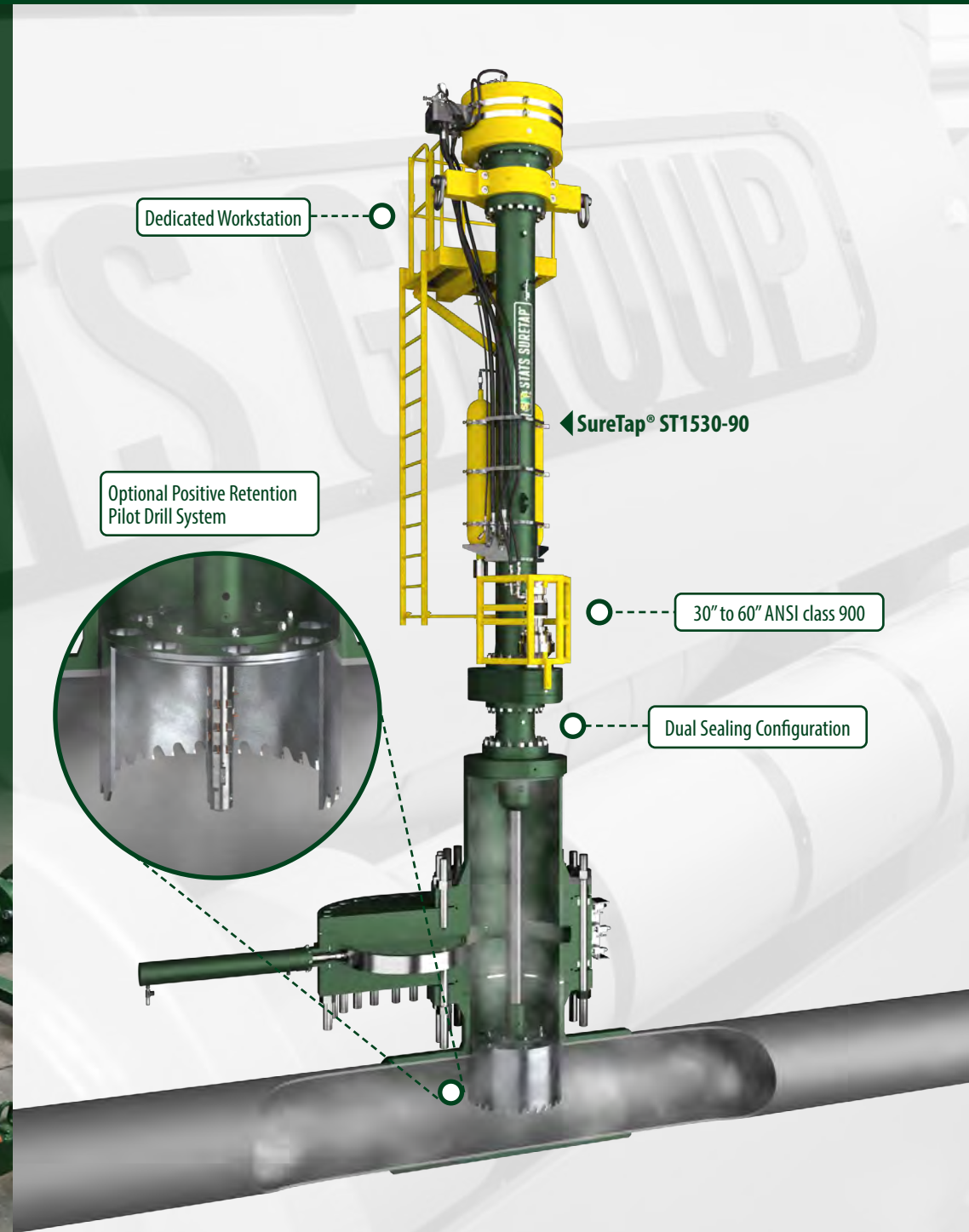

Legislation, Codes & Directives

Design Compliant with:

- ASME B16.5: Pipe flanges and flanged fittings**
- ASME B31.3: Process piping**
- ASME B31.4: Pipeline Transportation System for Liquid Hydrocarbons and Other Liquids**
- ASME B31.8: Gas Transmission & Distribution Piping Systems**
- ASME BPVC. Section VIII, Division 1: Design and Fabrication of Pressure Vessels**
- ASME BPVC. Section VIII, Division 2: Alternative Rules**
- NACE MR0175/ISO 15156-2: Petroleum and natural gas industries - Materials for use in H2S containing environments in oil and gas production.**
- EU directive 2006/42/EC: Machinery**
- EU directive 97/23/EC: Pressure equipment**



SureTap® ST410-90

SureTap® Range

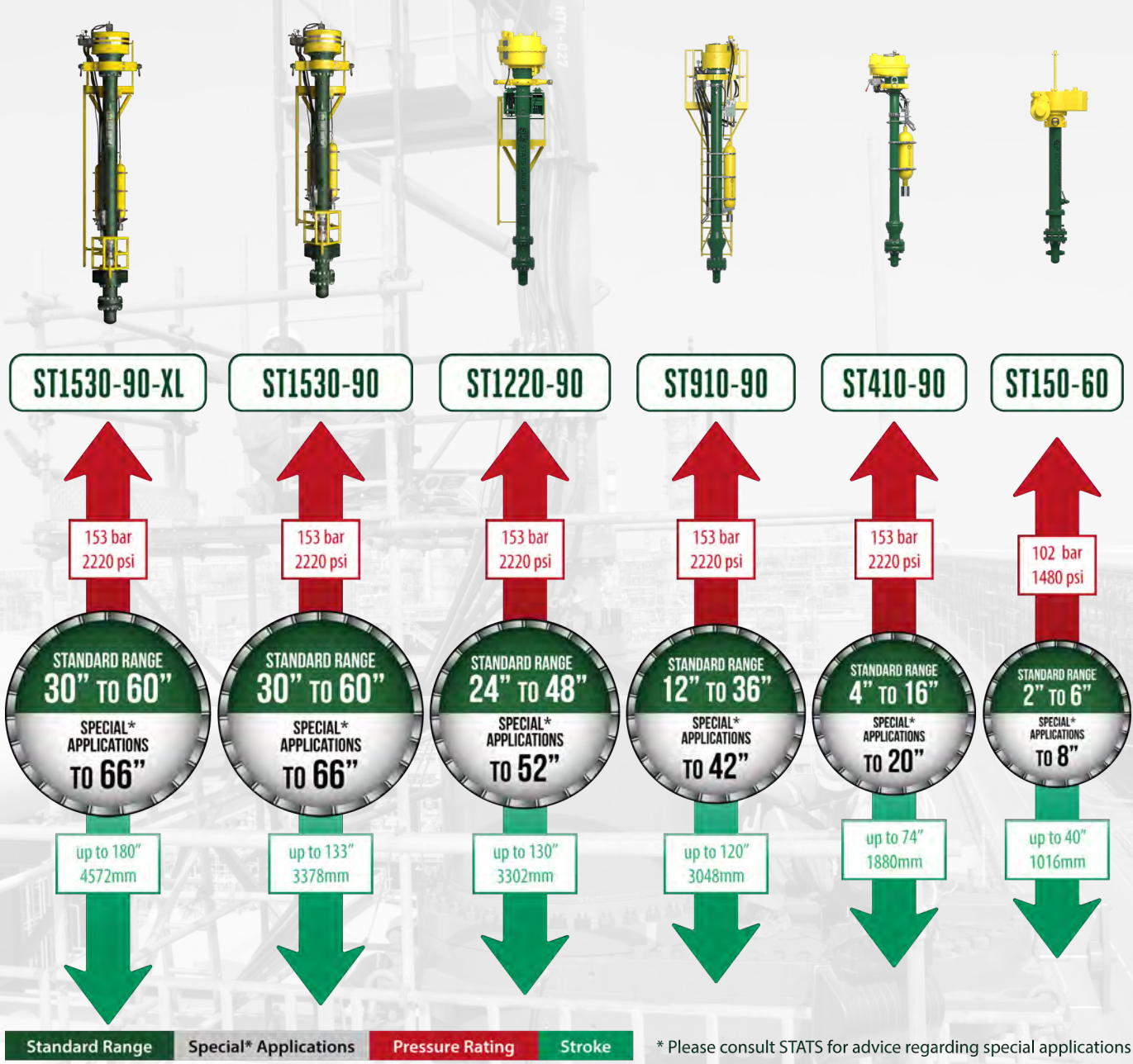

* Please consult STATS for advice regarding special applications

SureTap[®] ST1530-90-XL MACHINE

30" – 60"* cutter size

153 bar / 2220 psi pressure rating

- ✔ Process fluid seal housing features dual seal configuration
- ✔ Positive retention pilot drill system for robust securing and recovery of the cut pipe coupon
- ✔ Pressure compensated feed system
- ✔ Variable speed and feed configuration
- ✔ Suitable for use with sour (H2S) products
- ✔ Compatible with industry standard tapping equipment
- ✔ Capable of deploying and recovering completion plugs
- ✔ Dedicated transportation frame for secure shipping, storage and routine maintenance
- ✔ Dedicated work station for ease of use and operator safety
- ✔ Power provided from a portable, custom hydraulic power unit (HPU)
- ✔ Subsea compatible
- ✔ Pressure class: ANSI Class 900

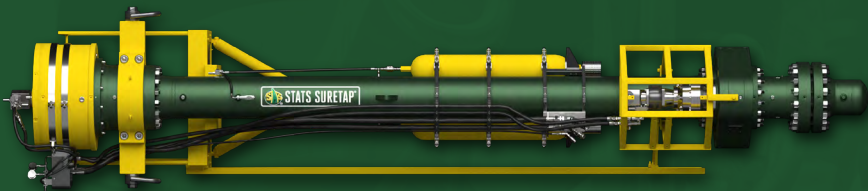

* Please consult STATS for cuts up to 66"

Operating Parameters

Pressure – temperature rating:	ASME B16.5 Class 900. Table 2 - 1.1	
Maximum operating pressure:	153 Bar @38°C	2220 psi @ 100°F
Operating temperature range - process fluid:		
<i>Standard configuration</i>	-20°C to 150°C	-4°F to 302°F
Operating temperature range - ambient (atmospheric):	-20°C to 40°C	-4°F to 104°F
Minimum cutter size:	30"	
Maximum cutter size: <i>STANDARD RANGE</i>	60"	
Maximum cutter size: <i>SPECIAL APPLICATIONS</i>	66"	
Boring bar rotational speed:	0 to 17 rpm	
Boring bar feed rates:		
<i>Feed rate 1</i>	0.08mm/rev	0.003"/rev
<i>Feed rate 2</i>	0.18mm/rev	0.007"/rev
<i>Feed rate 3</i>	0.28mm/rev	0.011"/rev
<i>Auxiliary feed</i>	343mm/min	13.5"/min
Boring bar travel:		
<i>Standard machine</i>	4572mm	180"
Machine weight:	6480kg	14286lbs
Overall dimensions, L x W x H:	7224 x 1400 x 1975mm	284.4 x 55.1 x 77.6"
Machine + Skid Weight:	7410kg	16336lbs
Shipping dimensions, L x W x H:	7300 x 1430 x 2110mm	287.5 x 56 x 83"

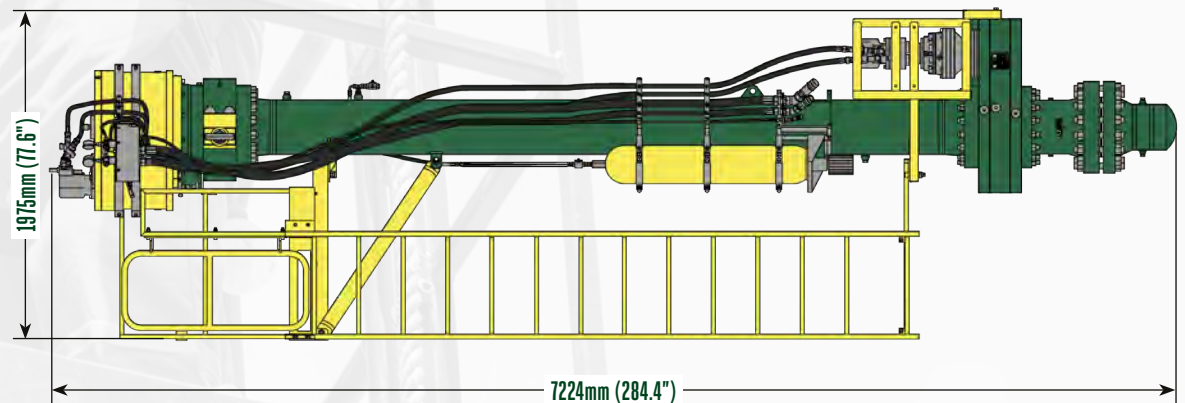

SureTap[®] ST1530-90 MACHINE

30" – 60"* cutter size

153 bar / 2220 psi pressure rating

- ✔ Process fluid seal housing features dual seal configuration
- ✔ Positive retention pilot drill system for robust securing and recovery of the cut pipe coupon
- ✔ Pressure compensated feed system
- ✔ Variable speed and feed configuration
- ✔ Suitable for use with sour (H2S) products
- ✔ Compatible with industry standard tapping equipment
- ✔ Capable of deploying and recovering completion plugs
- ✔ Dedicated transportation frame for secure shipping, storage and routine maintenance
- ✔ Dedicated work station for ease of use and operator safety
- ✔ Power provided from a portable, custom hydraulic power unit (HPU)
- ✔ Subsea compatible
- ✔ Pressure class: ANSI Class 900

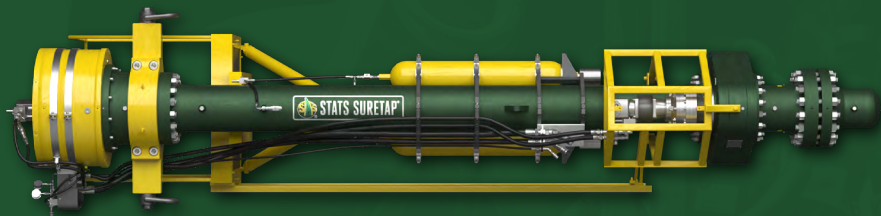

* Please consult STATS for cuts up to 66"

Operating Parameters

Pressure – temperature rating:	ASME B16.5 Class 900. Table 2 - 1.1	
Maximum operating pressure:	153 Bar @38°C	2220 psi @ 100°F
Operating temperature range - process fluid:		
<i>Standard configuration</i>	-20°C to 150°C	-4°F to 302°F
Operating temperature range - ambient (atmospheric):	-20°C to 40°C	-4°F to 104°F
Minimum cutter size:	30"	
Maximum cutter size: <i>STANDARD RANGE</i>	60"	
Maximum cutter size: <i>SPECIAL APPLICATIONS</i>	66"	
Boring bar rotational speed:	0 to 17 rpm	
Boring bar feed rates:		
<i>Feed rate 1</i>	0.08mm/rev	0.003"/rev
<i>Feed rate 2</i>	0.18mm/rev	0.007"/rev
<i>Feed rate 3</i>	0.28mm/rev	0.011"/rev
<i>Auxiliary feed</i>	343mm/min	13.5"/min
Boring bar travel:		
<i>Standard machine</i>	3378mm	133"
Machine weight:	6142kg	13541lbs
Overall dimensions, L x W x H:	6030 x 1400 x 1975mm	237.4 x 55.1 x 77.6"
Machine + Skid Weight:	6971kg	15369lbs
Shipping dimensions, L x W x H:	6100 x 1430 x 2110mm	240 x 56 x 83"

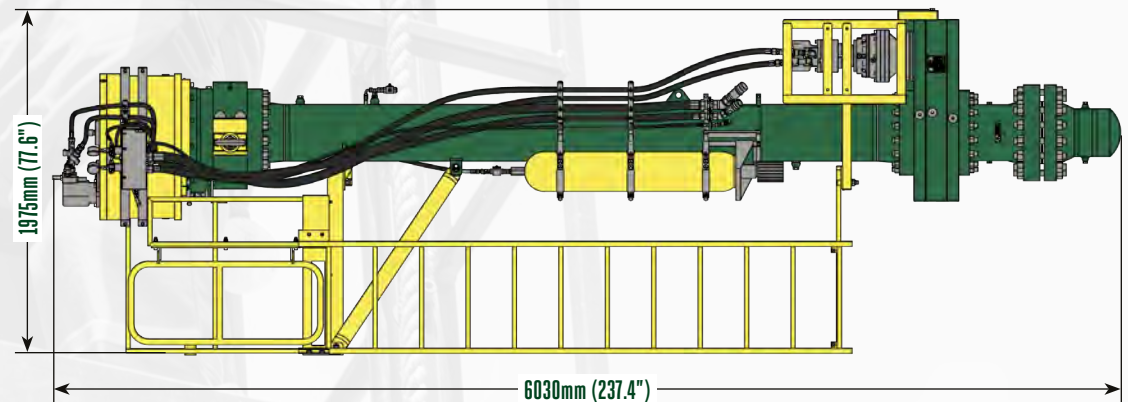

SureTap[®] ST1220-90 MACHINE

24" – 48"* cutter size

153 bar / 2220 psi pressure rating

- ✔ Process fluid seal housing features dual seal configuration
- ✔ Positive retention pilot drill system for robust securing and recovery of the cut pipe coupon
- ✔ Pressure compensated feed system
- ✔ Variable speed and feed configuration
- ✔ Suitable for use with sour (H2S) products
- ✔ Compatible with industry standard tapping equipment
- ✔ Capable of deploying and recovering completion plugs
- ✔ Dedicated transportation frame for secure shipping, storage and routine maintenance
- ✔ Dedicated work station for ease of use and operator safety
- ✔ Power provided from a portable, custom hydraulic power unit (HPU)
- ✔ Subsea compatible
- ✔ Pressure class: ANSI Class 900

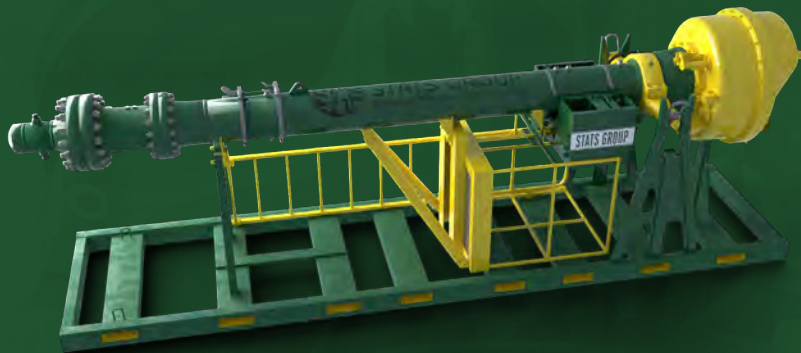

* Please consult STATS for cuts up to 52"

Operating Parameters

Pressure – temperature rating:	ASME B16.5 Class 900. Table 2 - 1.1	
Maximum operating pressure:	153 Bar @38°C	2220 psi @ 100°F
Operating temperature range - process fluid:		
<i>Standard configuration</i>	-20°C to 150°C	-4°F to 302°F
Operating temperature range - ambient (atmospheric):	-20°C to 40°C	-4°F to 104°F
Minimum cutter size:	24"	
Maximum cutter size: <i>STANDARD RANGE</i>	48"	
Maximum cutter size: <i>SPECIAL APPLICATIONS</i>	52"	
Boring bar rotational speed:	0 to 30 rpm	
Boring bar feed rates:		
<i>Feed rate 1</i>	0.13 mm/rev	0.005" / rev
<i>Feed rate 2</i>	0.18 mm/rev	0.007" / rev
<i>Auxiliary feed</i>	343mm/min	13.5"/min
Boring bar travel:		
<i>Standard machine</i>	3302mm	130"
Machine weight:	4650kg	10250lbs
Overall dimensions, L x W x H:	5927 x 1400 x 1812mm	233.3 x 55.1 x 71.3"
Machine with Ladder / Platform & Transport Frame Weight:	5120kg	11290lbs
Shipping dimensions, L x W x H:	6010 x 1430 x 1955mm	236.6 x 56.3 x 77"

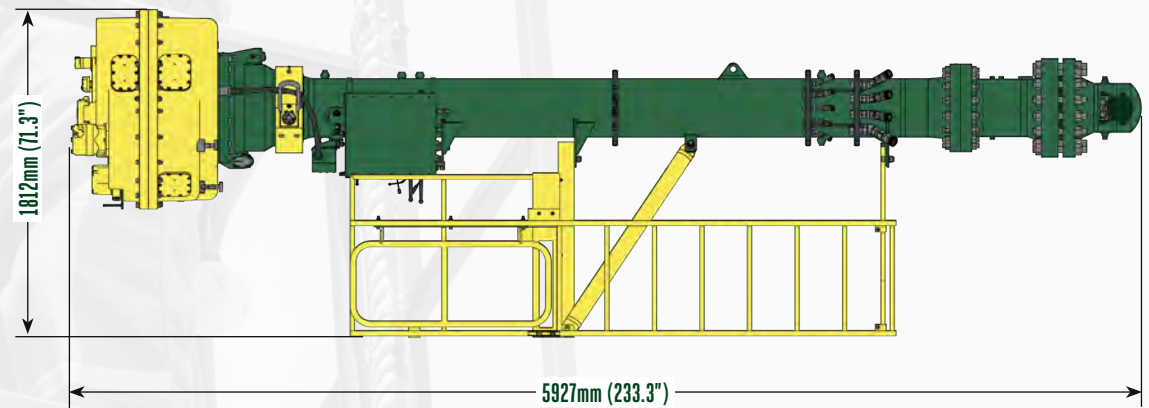

SureTap[®] ST910-90 MACHINE

12" – 36"* cutter size

153 bar / 2220 psi pressure rating

- ✔ Process fluid seal housing features dual seal configuration
- ✔ Positive retention pilot drill system for robust securing and recovery of the cut pipe coupon
- ✔ Pressure compensated feed system
- ✔ Variable speed and feed configuration
- ✔ Suitable for use with sour (H2S) products
- ✔ Compatible with industry standard tapping equipment
- ✔ Capable of deploying and recovering completion plugs
- ✔ Dedicated transportation frame for secure shipping, storage and routine maintenance
- ✔ Subsea compatible
- ✔ Pressure class: ANSI Class 900

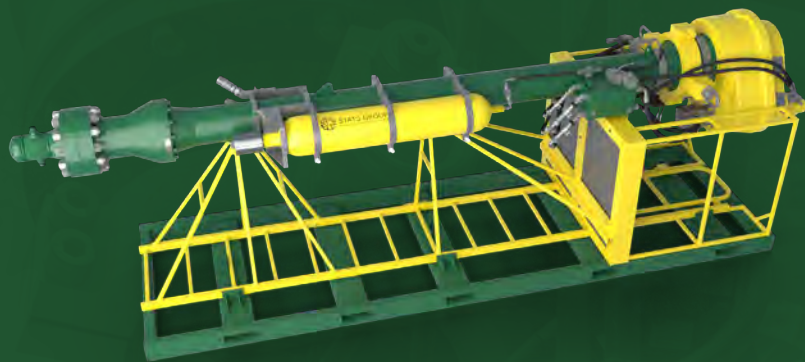

Operating Parameters

Pressure – temperature rating:	ASME B16.5 Class 900. Table 2 - 1.1	
Maximum operating pressure:	153 Bar @38°C	2220 psi @ 100°F
Operating temperature range - process fluid:		
<i>Standard configuration</i>	-20°C to 121°C	-4°F to 250°F
Operating temperature range - ambient (atmospheric):	-20°C to 40°C	-4°F to 104°F
Minimum cutter size:	12"	
Maximum cutter size: <i>STANDARD RANGE</i>	36"	
Maximum cutter size: <i>SPECIAL APPLICATIONS</i>	42"	
Boring bar rotational speed:	0 to 30 rpm	
Boring bar feed rates:		
<i>Feed rate 1</i>	0.10mm/rev	0.004" / rev
<i>Feed rate 2</i>	0.15mm/rev	0.006" / rev
Boring bar size:	101.6mm	4"
Boring bar travel:	3048mm	120"
Machine weight:	1934kg	4264lbs
Overall dimensions, L x W x H:	4839 x 1221 x 1322mm	190.5 x 48 x 52"
Machine with Ladder / Platform & Transport Frame weight:	2800kg	6172lbs
Shipping dimensions, L x W x H:	5131 x 1700 x 1422mm	202 x 66.9 x 56"

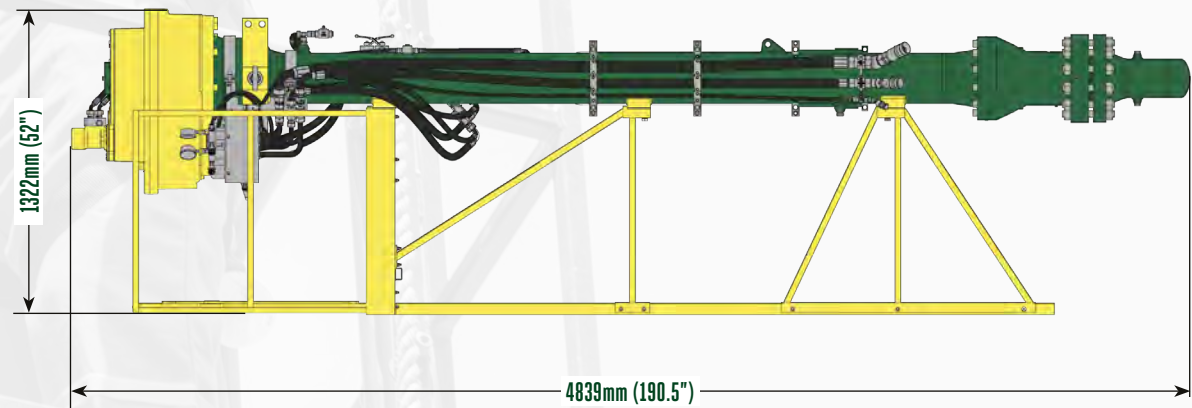

* Please consult STATS for cuts up to 42"

SureTap[®] ST410-90 MACHINE

4" – 16"* cutter size

153 bar / 2220 psi pressure rating

- ✔ Process fluid seal housing features dual seal configuration
- ✔ Positive retention pilot drill system for robust securing and recovery of the cut pipe coupon
- ✔ Pressure compensated feed system
- ✔ Variable speed and feed configuration
- ✔ Suitable for use with sour (H2S) products
- ✔ Compatible with industry standard tapping equipment
- ✔ Capable of deploying and recovering completion plugs
- ✔ Dedicated transportation frame for secure shipping, storage and routine maintenance
- ✔ Subsea compatible
- ✔ Pressure class: ANSI Class 900



Operating Parameters

Pressure – temperature rating:	ASME B16.5 Class 900. Table 2 - 1.1	
Maximum operating pressure:	153 Bar @38°C	2220 psi @ 100°F
Operating temperature range - process fluid:		
<i>Standard configuration</i>	-20°C to 121°C	-4°F to 250°F
Operating temperature range - ambient (atmospheric):	-20°C to 40°C	-4°F to 104°F
Minimum cutter size:	4"	
Maximum cutter size: <i>STANDARD RANGE</i>	16"	
Maximum cutter size: <i>SPECIAL APPLICATIONS</i>	20"	
Boring bar rotational speed:	0 to 40 rpm	
Boring bar feed rates:		
<i>Feed rate 1</i>	0.08mm/rev	0.003" / rev
<i>Feed rate 2</i>	0.13mm/rev	0.005" / rev
Boring bar size:	69.9mm	2.8"
Boring bar travel:	1880mm	74"
Machine weight:	540kg	1190lbs
Overall dimensions, L x W x H:	3139 x 611 x 592mm	123.6 x 24.1 x 23.3"
Machine with Ladder / Platform & Transport Frame weight:	809kg	1784lbs
Shipping dimensions, L x W x H:	3300 x 800 x 750mm	129.9 x 31.5 x 29.5"

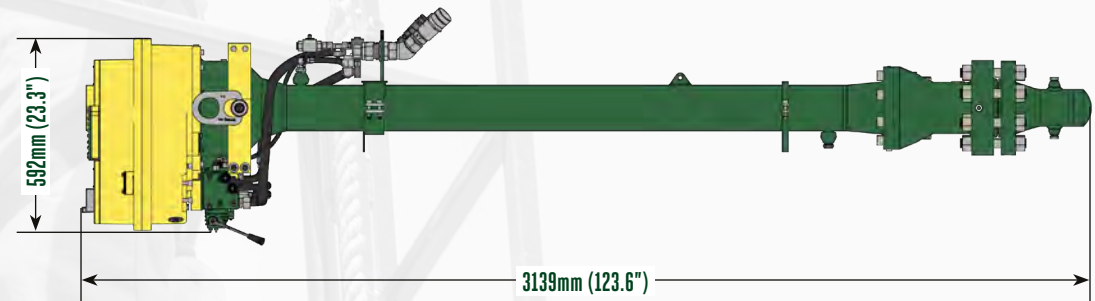

* Please consult STATS for cuts up to 20"

SureTap[®] ST150-60 MACHINE

2" – 6"* cutter size

102 bar / 1480 psi pressure rating

- ✔ Variable speed and feed configuration
- ✔ Suitable for use with sour (H2S) products
- ✔ Compatible with industry standard tapping equipment
- ✔ Capable of deploying and recovering completion plugs
- ✔ Dedicated transportation frame for secure shipping, storage and routine maintenance
- ✔ Subsea compatible
- ✔ Pressure class: ANSI Class 600



* Please consult STATS for cuts up to 8"

Operating Parameters

Pressure – temperature rating:	ASME B16.5 Class 600. Table 2 - 1.1	
Maximum operating pressure:	102 Bar @38°C	1480 psi @ 100°F
Operating temperature range - process fluid:		
<i>Standard configuration</i>	-20°C to 121°C	-4°F to 250°F
<i>High temperature service module</i>	0 to 370°C	32°F to 698°F
Operating temperature range - ambient (atmospheric):	-20°C to 40°C	-4°F to 104°F
Minimum cutter size:	2"	
Maximum cutter size: <i>STANDARD RANGE</i>	6"	
Maximum cutter size: <i>SPECIAL APPLICATIONS</i>	8"	
Boring bar rotational speed:	0 to 40 rpm	
Boring bar feed rates:		
<i>Feed rate 1</i>	0.08mm/rev	0.003" / rev
<i>Feed rate 2</i>	0.13mm/rev	0.005" / rev
Boring bar size:	42.8mm	1.7"
Boring bar travel:	1016mm	40"
Machine weight:	125kg	276lbs
Overall dimensions, L x W x H:	1632 x 595 x 405mm	64.3 x 23.4 x 15.9"
Machine with Transport Frame weight:	210kg	463lbs
Shipping dimensions, L x W x H:	1800 x 700 x 530mm	70.9 x 27.6 x 20.9"

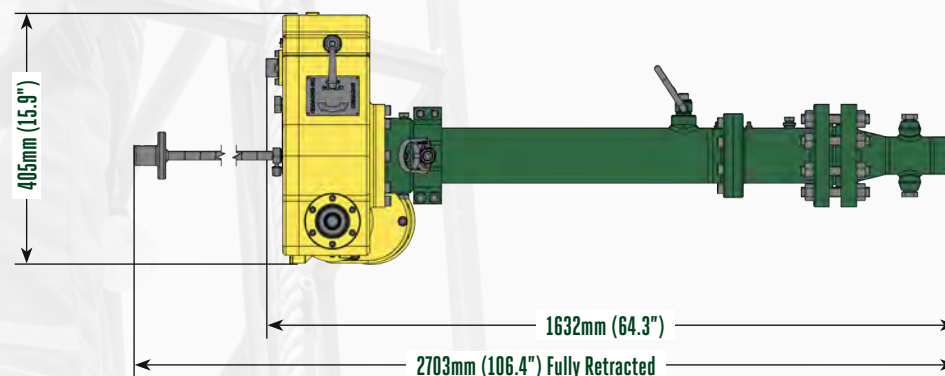



SERVICES

LEARN MORE ABOUT OUR COMPREHENSIVE RANGE OF PRESSURISED PIPELINE ISOLATION, HOT TAPPING, PLUGGING AND TESTING SERVICES



PRODUCTS

FIND OUT MORE ABOUT OUR EXTENSIVE RANGE OF PROPRIETARY PRODUCTS.



GET IN TOUCH

IF YOU HAVE A QUESTION OR WOULD LIKE MORE INFORMATION, WE ARE HERE TO HELP YOU



