

CASE IH
AGRICULTURE
FOR THOSE WHO DEMAND MORE

QUADTRAC & STEIGER AFS CONNECT™

TRACTORS 426 – 628 HP



IMPRESSIVE PERFORMANCE

- Powerful engine with up to 692 hp maximum power
- Up to 428 litres per minute flowrate for up to eight hydraulic remote valves
- Colossal rear lift capacity of 9,071kg
- Superior torque rise level of 40%

CONNECTIVITY MEANS EFFICIENCY

- AFS Connect telematics solution – the gateway to Quadtrac AFS Connect™ series tractors
- Extended remote capabilities
- Manage and optimize your farm, fleet, and data with AFS Connect at any time
- Remote screen sharing

A NEW WAY TO MANAGE YOUR FARM

- Intuitive AFS Vision Pro operating system featuring new AFS Pro 1200 LCD monitor
- New intuitive and ergonomic controls developed with our customers
- Industry-leading configurable buttons can be programmed with over 100 functions

NEVER EQUALLED

- Articulated steering and Tri-Point Oscillation delivers full power
- Four-track design distributes weight evenly over a total footprint of 5.6m²
- Oscillation of 26° is provided both upwards and downwards
- World's strongest continuously variable transmission

FREEDOM

TO FARM THE WAY YOU WANT



A PIONEERING CONCEPT	04 - 07
DECADES OF SETTING MILESTONES	08 - 09
CAB	10 - 23
ENGINE, TRANSMISSIONS, DRIVELINE	24 - 29
HYDRAULICS & PTO	30 - 33
CHASSIS	34 - 37

TRACKS	38 - 43
STEERING	44 - 45
AFS & AFS CONNECT	46 - 53
SERVICE	54 - 59
SUSTAINABILITY	60 - 61
SPECIFICATIONS	62 - 63

A PIONEERING CONCEPT

The one and only Quadtrac

For over 60 years, Quadtrac and Steiger series tractors have helped producers like you get more from the job in demanding conditions. We led the way in introducing a four-tracked articulated high-horsepower tractor – a heritage we are proud of. We were among the first tractor manufacturers to introduce a continuously-variable transmission with our pioneering CVXDrive 20 years ago. That heritage has now been combined with our most innovative and comfortable cab featuring a level of connectivity and telematics applications you've never seen before.

HUGELY SMART

The technology embedded in the completely redesigned cab is your key to unlocking a level of connectivity never before seen in a Case IH Quadtrac/Steiger tractor. Farm managers and operators can transfer information between the tractor, a phone, a tablet or a desktop computer, all wirelessly. Powered by AFS Connect telematics, you have the freedom to take the right decisions by leveraging all available data, at the right time, anywhere, from any device. This comes without sacrificing the power, efficiency, durability and productivity that Quadtrac/Steiger tractors are known for.

INCREDIBLY SIMPLE

The AFS Vision Pro concept featuring the innovative AFS Pro 1200 touchscreen monitor with Bluetooth functionality is standard in the new Quadtrac/Steiger. It was developed in cooperation with farmers all over the world for maximum user-friendliness and productivity.

ENORMOUSLY POWERFUL

The reliable, high pressure common rail 12.9 litre FPT engine (Stage V) and a powerful hydraulic circuit deliver high levels of power and fuel economy without compromise. Along with an unrivalled and patented chassis design featuring Tri-Point Oscillation, they ensure strength, stability and greater pulling power to handle your biggest implements.

AFS INTEGRATION

VectorPro GNSS receiver, AFS Connect™ with remote screen sharing and remote software updates, ISOBUS class III, AUX-N ISOBUS automation, Headland Management Control II for guidance consistency and accuracy.

CAMERAS

The AFS Pro 1200 has four camera inputs. Front and rear cameras are included with the deluxe technology and luxury cab packages.

LED GRILLE-MOUNTED WORK LIGHTS

Operate whenever you need to with lights that provide superior visibility at night.

ENGINE

In-line 6-cylinder FPT Cursor 13 engine (Stage V) provides leading fuel efficiency while maximizing power.

TRANSMISSION

Choose between the CVXDrive (highest-horsepower continuously variable transmission in the industry) or the proven 16-speed PowerDrive powershift transmission

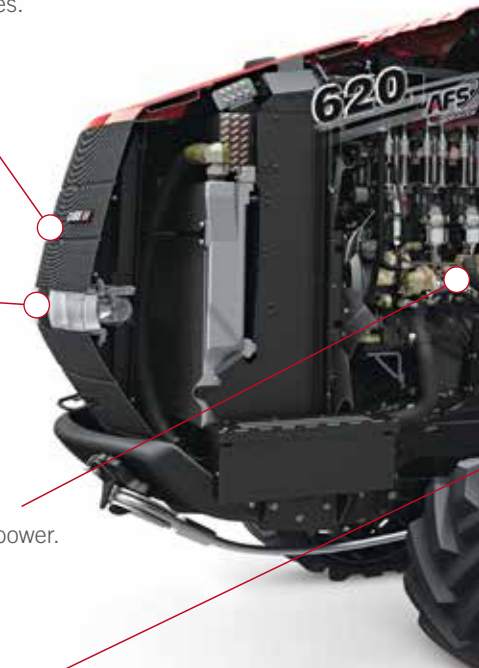



NEW OPERATING CONCEPT

New Multicontroller armrest with fully customizable control elements (Multicontroller, remote valve levers, joystick and configurable buttons) and the new dial button encoder for quick access to the work and setting menus.

STANDARD 4-POINT CAB SUSPENSION

Stabilizes front-to-back, side-to-side and up-and-down motion,s creating a smooth ride regardless of terrain.

HYDRAULICS

The fully-configurable remote valve controls and TwinFlow™ pump provide an impressive flowrate with optimal control.

CAST UNDERCARRIAGE SYSTEM

Heavy-duty cast undercarriage designed by Case IH engineers for the rugged frame of Quadtrac tractors, enhancing durability and reliability.

TRI-POINT OSCILLATION

Transfers more weight to the front for a 50/50 weight distribution under load, providing increased traction and reduced compaction.

AUTOMATIC TRACK TENSIONING

The track is automatically tensioned by hydraulic pressure, keeping you up and running.

POWER ON WHEELS

Steiger AFS Connect

4WD force makes Steiger wheeled tractors ideal for everything from pulling large planters and strip-till rigs to pushing silage and towing grain carts. Plus, get more traction and less compaction with a longer wheelbase and the tallest factory-fit row crop tires in the industry.

MOST POWERFUL WHEELS ON THE MARKET

It's one thing to produce a lot of horsepower, which the Steiger 620 wheeled tractor does better than any other. But what really matters is moving this industry-leading power efficiently throughout the tractor and, ultimately, to the ground and implement. Superior tractive capabilities using automatic differential locks reduce slippage in difficult field conditions.

NEW FRONT CAB ROOF MOUNTED LED LIGHTS

New customizable LED lights provide enhanced front and side visibility, giving operators the freedom to program them to meet their operation's specific needs.

PROVEN ENGINES

The Case IH FPT engine has passed every challenge and is built with efficiency in mind. Case IH FPT 8.7 liter and 12.9 liter engines incorporate patented fluid-saving SCR-only technology for greater productivity to produce more power using less fuel. And, with 600 hour oil-change intervals, you'll achieve greater fluid efficiency and lower operating costs.

POWERDRIVE POWERSHIFT TECHNOLOGY

With the latest Steiger enhancements, it takes 20% less time to shift from first gear to 16th gear, saving you fuel, lowering operating costs and reducing fatigue. And during shuttle operation, a producer can change direction 38% faster than before.





PATENTED SCR SYSTEM

Eliminates the need for engine regeneration and provides increased fuel efficiency.

STANDARD ADVANCED STEERING SYSTEM

The Case IH Advanced Steering system that gives an operator smoother and more precise control of the tractor and implement comes standard on every Steiger tractor. Unlike previous systems that required four full side-to-side turns for field applications, this system only requires 3 1/2 turns. Choose between slow, medium and fast modes to tailor the steering to your applications.

STRUCTURAL STEEL FUEL TANK

Every Steiger AFS Connect fuel tank is made of durable structural steel, unlike competitive offerings. This important design difference adds additional weight and strength to the Steiger chassis.



STANDARD HEAVY-DUTY AXLES

Steiger AFS Connect heavy-duty axles can carry up to 30 t of gross vehicle operating weight. These 14 cm diameter axles with 18-bolt hubs also feature unparalleled braking and hydraulic pressure. It all adds up to greater strength and durability.

All new Steiger AFS Connect 500 & 540 models feature new heavier 12.5 cm bar axles on both ag and scraper versions.

DECADES OF SETTING MILESTONES

A powerful heritage

The Steiger story can be traced back more than half a century to 1958, when farming brothers Douglas and Maurice Steiger built their first articulated four-wheel drive tractor in a barn on the family farm in Minnesota, USA. Six years later, production was moved to a dedicated facility in Fargo, North Dakota, where Steigers are still made today.

1997 witnessed the biggest revolution yet in the articulated tractor sector: Case IH introduced the four-tracked pivot-steer format with the launch of the Quadtrac. Since then, the four-track system has been further developed and refined to create the tractor that continues to lead the high hp tracked segment. This year marks another revolution with the introduction of the CVXDrive transmission for Steiger and Quadtrac.

INVENTION OF THE FIRST STEIGER TRACTOR

John Steiger and sons Douglas and Maurice build the first Steiger tractor in a barn on their Minnesota farm. At 238 hp, it is the first articulated four-wheel drive tractor with a power output of more than 200 hp.



INTRODUCTION OF STEIGER PANTHER 1000 TRACTOR

The Steiger Panther 1000 tractor is the first model to have a 12-speed full powershift transmission, electronic controls, a new deluxe cab and pressure flow compensating hydraulics.





WORLD'S FIRST HIGH HP TRACTOR

The Steiger Quadtrac, the world's first articulated high hp tractor with rubber tracks in place of wheels, is introduced with a single 360 hp model.



The new Steiger / Quadtrac Efficient Power models are introduced. Fulfilling the Stage IIIB emissions levels, this marks a significant step to cleaner emissions and better fuel efficiency.

20TH ANNIVERSARY

The Steiger 620 sets new records for drawbar fuel efficiency, drawbar horsepower and maximum pull at the internationally-renowned Nebraska Tractor Test Laboratory.

For the 20th anniversary of Quadtrac tractors, Case IH introduces the CVXDrive continuously-variable transmission option for Steiger 370-540 and Quadtrac 470-540 models.



FARMING 4.0

The Quadtrac AFS Connect series sets a new landmark in the future of farming. Precision farming, farm management, data sharing and remote support services provided by AFS Connect are the next step forward in agriculture.



19
88

19
97

20
08

20
10

20
14

20
17

20
19

20
20 FUTURE

The distinctive Steiger lime green livery is exchanged for the equally famous red of Case IH, with the launch of a new range of 9100 series tractors made in Fargo.



Case IH introduces Gold Signature Edition models to celebrate the 50th anniversary of Steiger tractors.



50TH ANNIVERSARY

The world's strongest serial production tractor, the Quadtrac 620, is voted Machine of the Year 2014 by a jury of 28 agricultural machinery journalists from across Europe.



The Quadtrac 540 CVXDrive was honored in the "XL" tractor category in recognition of the benefits of the CVT transmission, as well as the fuel efficiency and operating benefits brought to articulated tracked tractors.



1990
1991
1992
1993
1994
1994
1994
1996

1998
1999

2011
2012
2013

2018

1989

2000
2001
2002
2003
2004
2005
2006
2007

2009

2015
2016





COMFORT AT THE HIGHEST LEVEL

The workplace of the future

Comfort is one of the hallmarks of Quadtrac and Steiger models, and perfectly complements the power, efficiency, durability and productivity that they are known for. With proven Case IH four-point cab suspension, you will enjoy a smooth, vibration-free ride regardless of terrain. Case IH engineers used years of research and input from our most qualified experts – you.

The result is an interior that blends simplicity, control and luxury like you've never experienced in a tractor cab before. The premium materials are matched by an intuitive and configurable AFS Pro 1200 monitor interface which keeps the most important information in view.

YOUR COMFORT ALWAYS COMES FIRST

A cab environment like no other

Long farming days benefit from the in-cab technologies of the new Quadtrac/Steiger. With one of the biggest cab in the industry and unique all-round visibility, we make sure you get a luxuriously smooth ride.

UNSURPASSED REAR VIEW

With a driver's seat that can pivot 40 degrees to the right, you'll have a better view of your implements. No more twisting and turning to see behind the machine – you'll end the day as relaxed as you began it.

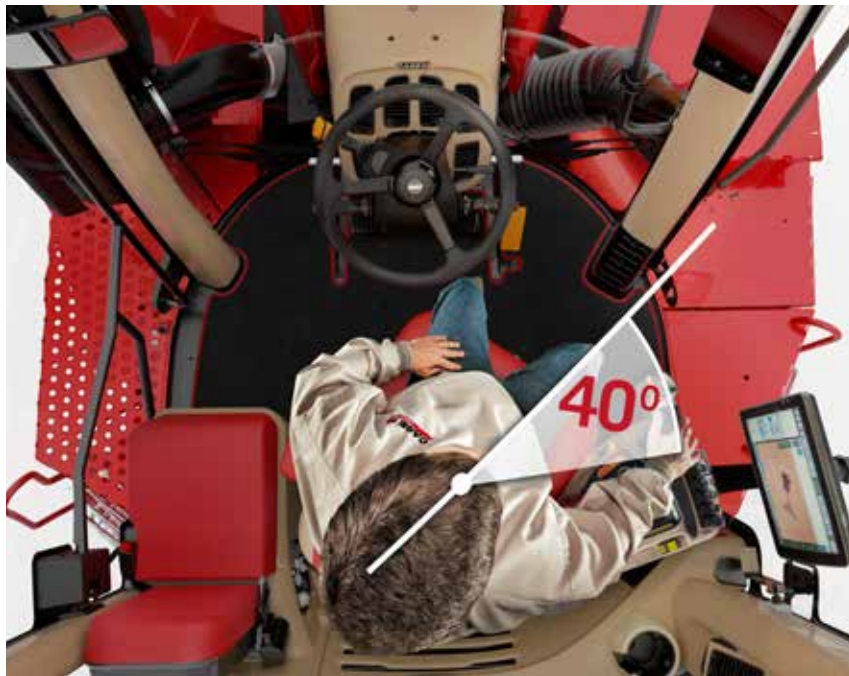

HEATED AND VENTILATED SEAT

Quadtrac/Steiger AFS Connect tractor's optional heated and ventilated red leather seat keeps you cool and comfortable in warm months.



MASTER OF ALL SEASONS

The new pressurized HVAC system features more vents and louvers to increase air flow around the operator. It can also be controlled directly via the encoder or the configurable buttons.



ELEVATED FOOTREST

The elevated footrest on either side of the steering column provides a welcome alternative position. You will be able to stretch your legs during long working days

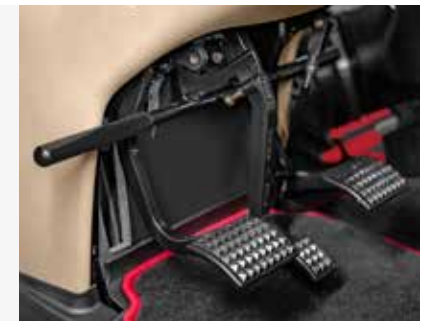

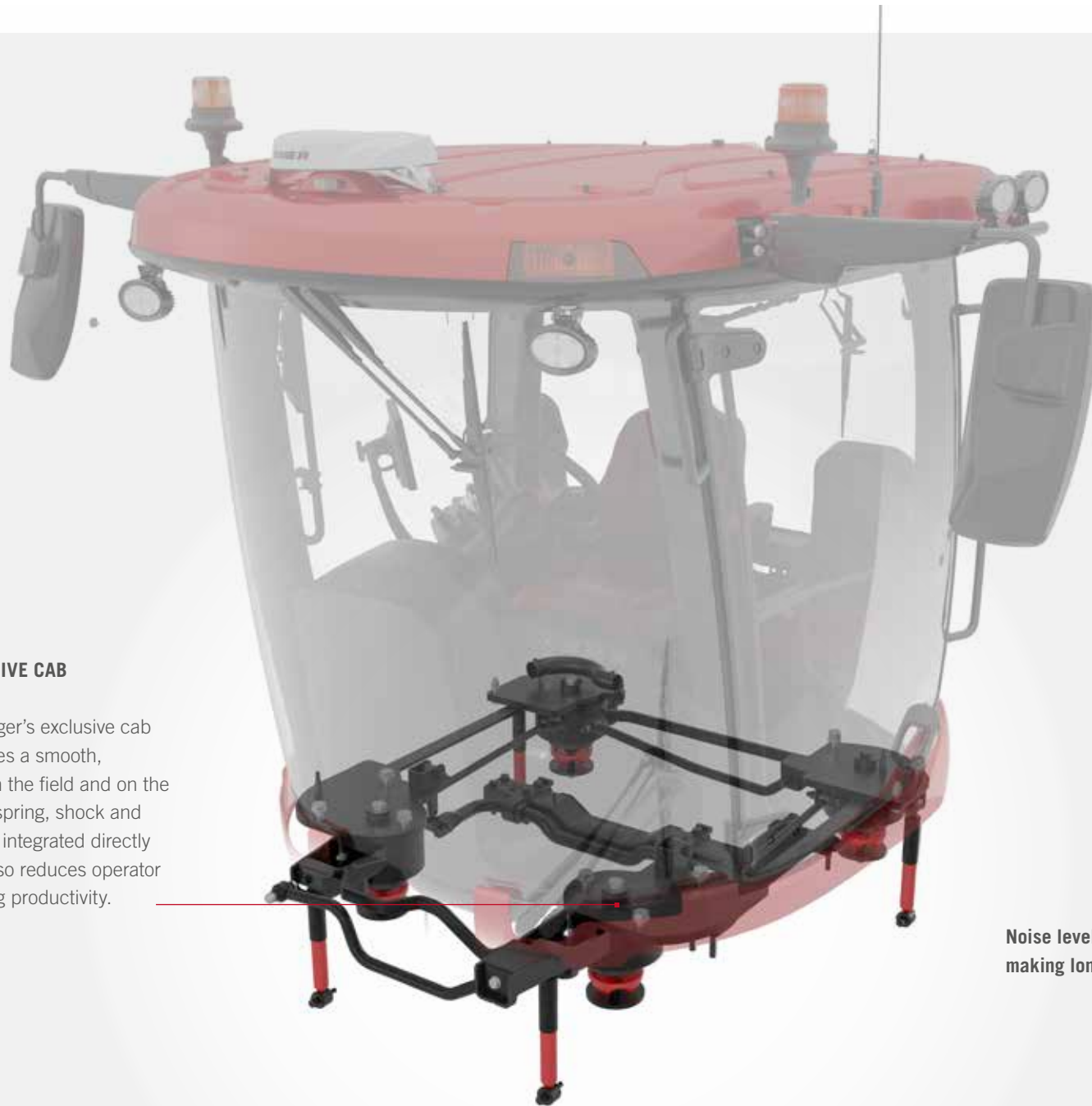

INDUSTRY-EXCLUSIVE CAB SUSPENSION

The Quadtrac/Steiger's exclusive cab suspension provides a smooth, comfortable ride in the field and on the road. The 4-pillar spring, shock and stabilizer system – integrated directly into the frame – also reduces operator fatigue, maximizing productivity.

Noise levels are extremely low at 74.5 dB(A), making long operating periods a pleasure.

ERGONOMICS MAKE FARMING EASIER.

We help you to focus on what's really important.

Comfort and safety go hand in hand, which is why we have designed the new Quadtrac/Steiger AFS Connect with the best visibility in its class. The 4-pillar design provides a 360° view while various cameras and superior drawbar visibility leave you feeling safe and in control.

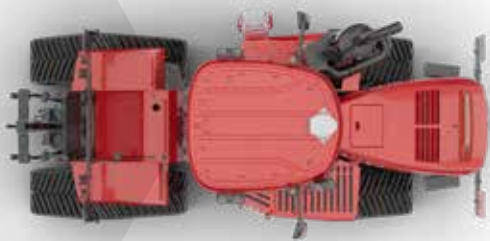

ALL-AROUND VISIBILITY

Up to four cameras can be installed around the front and rear of the machine. You can set-up your AFS Pro 1200 monitor to keep an eye on blind spots and improve your visibility.



ALL CLEAR TO THE RIGHT

The after-treatment system is positioned unobtrusively, giving you a perfect view from the right hand side of the machine. This design increases your safety and comfort in working conditions.



IMPLEMENTS UNDER CONTROL

The divided remote valve block and the fuel tank design permits best visibility to the drawbar pin, making implement connection a one-person job.



ELECTRONIC TELESCOPING MIRRORS ARE CONTROLLED FROM INSIDE THE CAB FOR GREATER COMFORT. THE OPERATOR ALWAYS HAS THE BEST OVERVIEW OF HIS OR HER SURROUNDINGS, EVEN WHEN USING LARGE IMPLEMENTS IN CONFINED SPACES.

THE SPECIAL QUADTRAC DESIGN GIVES THE OPERATOR PERFECT VISIBILITY TO THE FRONT.

IT ALL STARTS WITH THE ERGONOMIC CAB ENTRANCE. THE STAIRS AUTO-PIVOT WHEN TRACTOR IS ARTICULATING AND PROVIDE SIMPLE ACCESS WITHOUT ANY LIMITATION ON STEERING RADIUS



IT'S YOUR CHOICE!

Two different cab trim packages to suit your needs

For those who would like even more comfort, Case IH offers the **Luxury Cab** with electrically adjustable and telescoping mirrors. A ventilated premium leather seat, leather steering wheel, leather passenger seat and carpeted floors give you a feeling of pure luxury as you work efficiently and productively. This package also includes standard front and rear cameras, giving you the best overview of your surroundings.

LUXURY CAB – STANDARD features

- 4 post cab suspension - mechanical
- Leather steering wheel
- Active leather seat (40° right hand swivel)
- Leather passenger seat
- Carpet - black & red
- Bluetooth radio with high-performance speakers
- Front, rear and side sun shades
- Electrically adjustable and electrically telescoping wide-angle mirrors
- Front & rear cameras factory installed
- Accent lighting
- Additional USB connections, 3-pin and 230V power sockets

The **Deluxe cab trim package** is an economical solution with many details to maximise productivity and user friendliness. If you'd like even more comfort and more features, you'll love our **Deluxe Technology™ cab** with mechanical cab suspension. Perfect for demanding customers who want to work quickly, precisely and safely.

DELUXE PERFORMANCE CAB

- Mechanical cab suspension
- Active fabric seat with heating
- Radio with Bluetooth
- Front, rear and side sun shades
- Electrically adjustable and mechanically telescoping wide-angle mirrors
- Additional USB connections, 3-pin and 230 V power sockets



STAY ALERT DAY AND NIGHT

When time is critical, days often extend into nights. For maximum illumination, Quadtrac and Steiger AFS Connect series tractors are equipped with new LED lights enhancing front and side visibility.





NEW 12-INCH AFS PRO 1200 DISPLAY WITH TOUCH SCREEN AND BLUETOOTH® CAPABILITIES — POWERED BY THE NEW AFS VISION PRO OPERATING SYSTEM: JUST LIKE USING A SMARTPHONE OR TABLET

CONFIGURABLE HOT KEYS 5 – 8



MULTIFUNCTION HANDLE PUTS 95% OF THE COMMONLY USED CONTROLS AT YOUR FINGERTIPS

CONFIGURABLE, COLOR-CODED ELECTRO-HYDRAULIC REMOTE (EHR) LEVERS



MULTICONTROLLER ARMREST PROVEN DESIGN NOW FEATURES A DIAL ENCODER FOR TOTAL CONTROL AT YOUR FINGERTIPS



THE EASIEST WAY TO BE PRODUCTIVE

An operating system that sets new standards

We know how busy you and your employees are. That's why we've made sure no time is wasted with resetting preferences when changing drivers or changing jobs. The Multicontroller armrest with its ergonomic layout gives you a new sense of control to get the most out of your Quadtrac and Steiger tractor. 95% of the most commonly used functions are right at your fingertips.

DEVELOPED BY OUR BEST PARTNERS: OUR CUSTOMERS

You won't have to go far to find what you need. The armrest position can be adjusted in four directions to suit any driver.

CONFIGURABLE HOT KEYS 1 – 4

INTEGRATED ENCODER OPERATING SYSTEM
EASY TO USE AND NAVIGATE THE AFS MONITOR

PRE-PROGRAMMED HOT KEYS

The monitor pivots through 52 degrees so you can have it just where you want it.



OUR FOCUS: YOUR NEEDS

New Multicontroller for maximum adaptability and comfort

AT YOUR FINGERTIPS

The ergonomic multicontroller was redesigned to include reconfigurable tractor functions. It's easy to reach on the armrest and features more functionality than ever before, including control of the front and rear remote valves, all transmission settings as well as ISOBUS functions.

1 ACCUGUIDE ENGAGE

2 CUSTOMIZABLE CONTROLS FOR EACH DRIVER'S PREFERENCES

The four freely-configurable buttons on the Multicontroller can be personalized with whatever functions you like so everything is always in reach. Choose from engine settings, electronic remote valves, Precision Farming, transmission, heating and air conditioning, phone and more!

3 UP/DOWN SHIFT FOR POWERDRIVE OR TARGET SPEED FOR CVXDRIVE

4 POWERSHUTTLE

Additionally on the right hand side. This gives the operator the best flexibility to change directions.

5 CONFIGURABLE HYDRAULIC REMOTE VALVES

4 buttons on the remote valve pad can be mapped to any remote valve. The shift button on the back activates the float position.

6 REAR THREE-POINT LINKAGE

Front three point linkage in combination with shift button on the back

7 THUMB WHEEL FOR TARGET SPEED ADJUSTMENT

8 HEADLAND MANAGEMENT CONTROL (HMC)



9 11 buttons can be used to control ISOBUS functions.



DEVELOPED FOR HIGHEST DEMANDS

Experience the next level.



New shortcut keys make navigation a breeze.

EXCLUSIVE ENCODER KNOB

The integrated encoder allows an easy navigation and an accurate AFS monitor set-up under harsh field condition. Pushing the encoder opens the adjustment menu of your:

- Hydraulic system
- Engine
- PTO
- Radio & mobile phone
- Work lights
- Three-point linkage
- Heating system

The encoder gives you a sure touch and ergonomics especially while driving even in the most severe conditions so you are always in total control.



The icons on all switches are backlit when the headlights are on.

A-PILLAR DISPLAY

The newly-designed colour display mounted on the A-pillar shows the driver an overview of the most important data regarding the fuel tank, AdBlue fill level, coolant temperature, transmission, rear hitch, PTO speed and ground speed. Its slim design fits unobtrusively into the A-pillar so as not to block your view out the front windscreen or side window.

THE MOST IMPORTANT FUNCTIONS

The control panel on the armrest has been completely redesigned. The buttons are grouped and colour-coded so you can tell them apart more easily. Transmission and engine-related function buttons are orange, for example, while PTO buttons are yellow.



AFS PRO 1200 TOUCHSCREEN MONITOR

The high-res allrounder



SETTINGS JUST FOR YOU

The AFS Pro 1200 monitor gives you an overview of all tractor functions. It's easy to optimize the hydraulics, PTO, engine and transmission. Just use the Case IH encoder and shortcut keys for total control of your tractor's functions.



VIDEO INPUT

The monitor can show live video from several cameras at the rear of the tractor, or the rear of large implements such as a trailer or baler. This makes backing up with large implements easier than ever. One camera at the front and one at the rear can be factory-installed.



THE FREEDOM OF AUTOMATION WITH HMC II

The Quadtrac/Steiger AFS Connect includes as standard the innovative headland management system HMC II to automate repeating processes. To increase productivity, processes can be recorded in real time while you work, or by inputting commands on the AFS monitor. Save valuable time in the headland and concentrate on your work.



EVERYTHING IN VIEW, EVERYTHING UNDER CONTROL

The high-res AFS Pro 1200 is as easy to use as your smartphone. Each driver can configure and save submenu and shortcut options to suit their needs.



This lets every driver utilize the full potential of the machine without annoying reconfiguration of preferences.

THE FREEDOM OF CONTROL

ISOBUS is a modern tractor/implement interface which allows the implement's operating screens to be displayed on the AFS Pro 1200 monitor. You don't need another monitor, saving you money. ISOBUS III allows the implement to control elements of the tractor, for example the remote valves, PTO, the position of the rear hydraulics and ground speed.



THE FREEDOM OF CHOICE

The AFS Pro 1200 monitor allows you to choose from over 100 functions to assign to eight freely-programmable keys. Functions like radio volume, air conditioning fan speed or to answer/end phone calls can then be easily operated using the programmable buttons on the Multicontroller or on the Integrated Control Panel (ICP). Your drivers always have the ideal settings at their fingertips.



PERFORMANCE MONITORING

The monitor also records total performance and daily stats. All data is sent directly from the AFS Pro 1200 monitor to your MyCase IH platform for further analysis.







ENGINEERING THE FUTURE

Industry-leading power and performance

Quadtrac and Steiger AFS Connect models produce some of the highest power outputs available, with as much as 692 hp peak power available with the Quadtrac/Steiger 620. Case IH Stage V engines by FPT - featuring common rail fuel systems and a patented Case IH FPT SCR2-only emissions system - offer power, performance and fuel economy with no active exhaust cleaning required. They also deliver more low-end torque to allow the engine to lug down and recover more quickly.

The powerful engine is combined with your choice of the world's strongest continuously variable CVXDrive transmission or the proven 16-speed PowerDrive transmission, delivering unmatched efficiency and power to the ground. Whatever your choice, you are guaranteed excellent power efficiency, power transfer to the ground and traction, even with the heaviest implement.

THE ENGINE FOR A NEW ERA

Further considered. Further developed.

**600 H
SERVICE
INTERVAL**



Delivering the highest power output in their class, Case IH Steiger and Quadtrac tractors are powered by a high pressure common rail 12.9 litre FPT engine featuring a two-stage turbo and newly-developed cooling system.

POWERFUL ENGINE

The heart of the Quadtrac/Steiger AFS Connect is its innovative Cursor 13 engine, delivering 469 - 692 hp at maximum power. The in-line 6 cylinder, 12.9 litre engines feature 4 valves per cylinder for better gas exchange and utmost reliability. Two different engine speeds can be stored so that the fuel injection system keeps engine rpm constant even under increased load.

STRONG IN EVERY SITUATION

At 1900 rpm engine speed, Cursor 13 engines can achieve up to 10% power growth, providing maximum performance in the toughest conditions. They also feature a two-stage turbocharger system with separate cooling system, delivering 40% faster response under load.

ENVIRONMENTALLY FRIENDLY AFTER-TREATMENT SYSTEM

The patented and highly efficient Selective Catalytic Reduction (HI-eSCR2) system meets strict Euro stage V emission standards without compromising engine performance. The system will perform automatically to help reduce the contaminants and does not require any operator action, so you can stay up and running all day long.

LONG WORKING DAYS GUARANTEED

The innovative steel fuel tanks have a capacity of 1881 litres to keep you working all day. The fuel fill point is easy to access, with steps and hand rails leading up to a standing platform.

ADVANTAGES

- FPT Cursor 13 engines from 469 hp to 692 hp (maximum power)
- High Efficiency Selective Catalytic Reduction (HI-eSCR2)
- 1,881 l fuel tank guarantees long working days without refuelling
- Superior torque rise of 40%
- Constant engine rpm even under increased load

HI-eSCR2



The FPT Cursor 13 engine uses two-stage exhaust gas turbocharging to guarantee high boost pressure over the entire speed and load range. This prevents turbo lag in the lower speed range

An outstanding torque rise of 40% minimises engine speed drop under high load

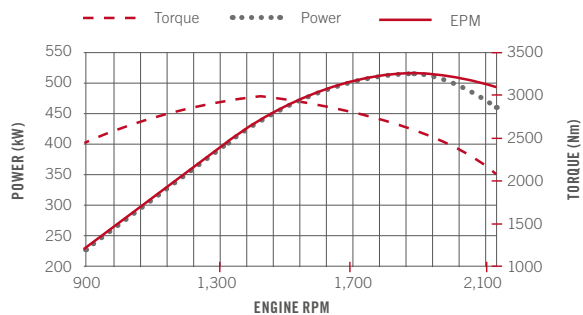

STAGE V COMPONENTS:
 DIESEL OXIDATION CATALYST (DOC)
 ADBLUE INJECTION AND ADBLUE MIXING UNIT
 SELECTIVE CATALYTIC REDUCTION
 CLEAN-UP-CATALYST (CUC)

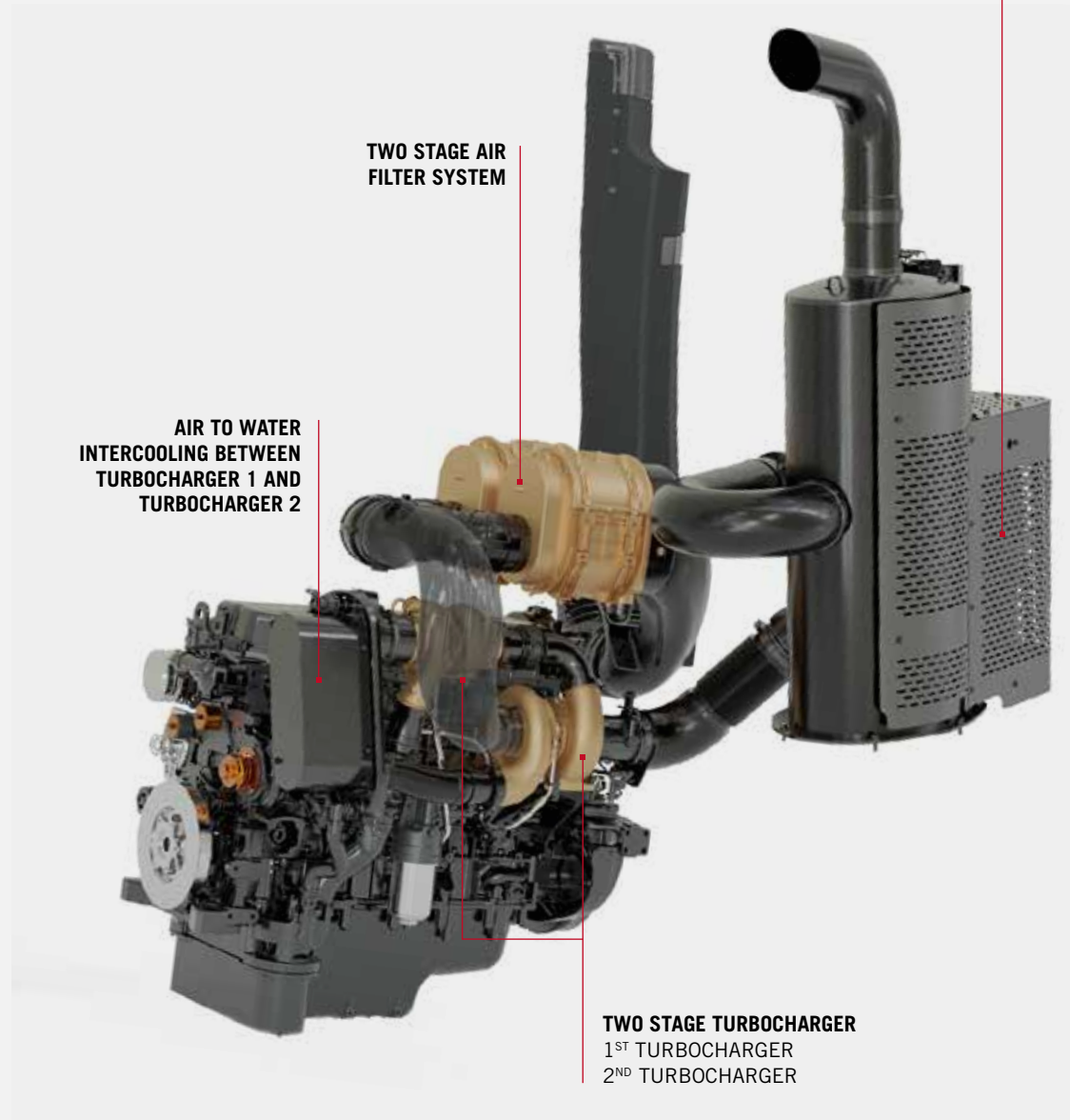

TWO STAGE AIR FILTER SYSTEM

AIR TO WATER INTERCOOLING BETWEEN TURBOCHARGER 1 AND TURBOCHARGER 2

TWO STAGE TURBOCHARGER
 1ST TURBOCHARGER
 2ND TURBOCHARGER

POWERDRIVE: THE PROVEN FULL POWERSHIFT TRANSMISSION BY CASE IH

Efficient power transfer for more productivity

AVAILABLE FOR ALL QUADTRAC AND STEIGER AFS CONNECT SERIES TRACTORS

The 16-speed, full powershift Quadtrac/Steiger transmission shifts smoothly for high efficiency, low wear and reduced fatigue at the end of a long day in the field.

SMOOTHEST RIDE

A long day in the field need not mean a fatigued operator with Powershift's efficient shifting. Pulse-width modulation provides the smoothest possible shifts under load in order to maintain momentum and minimise power losses.

EASE OF USE AND GREATER EFFICIENCY

The fuel-efficient 16-speed PowerDrive powershift transmission allows up to 20% faster acceleration with each gear change. Plus, Case IH engineering tests have proven that recent enhancements to the PowerDrive can save up to 2% horsepower - helping you work more productively.

SMART AND EFFICIENT WITH APM

APM automatically selects the most suitable engine speed and gearbox ratio combination to perform the task at hand. As it recognizes your driving strategy, you can count on the right power output, at the right moment, in the most efficient configuration possible without having to give it a single thought. The fuel savings can be remarkable: while planting at a constant 9 kph, you can save up to 24% on fuel.

POWERDRIVE APPLICATIONS

- Tillage
- Disc harrow
- Cultivators

ADVANTAGES

- Shifting through all gears without torque interruption
- Skip Shift function allows you to skip a gear to reach the desired ground speed as fast as possible
- Right hand power shuttle allows direction changes without releasing the steering wheel
- Automatic Powershift for superior comfort in fields and on roads
- Adjustable start up gear for stress free operation

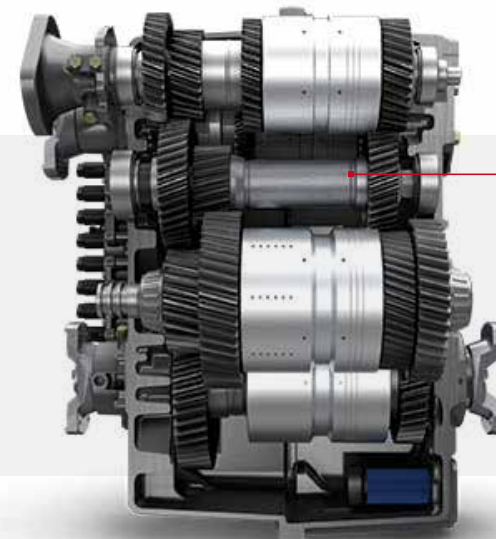

**20%
FASTER
SHIFTING
SPEED**

CVXDRIVE – THE CONTINUOUSLY VARIABLE DRIVE

Top level reliability and efficiency

AVAILABLE ON QUADTRAC/STEIGER 470, 500 AND 540 CVXDRIVE

The CVXDrive continuously variable transmission is built to simply deliver the exact speed for your operation without compromise.

THE WORLD'S STRONGEST CONTINUOUSLY VARIABLE TRANSMISSION

The proven CVXDrive transmission delivers uninterrupted power to the ground, incorporating four ranges to be more efficient and deliver more power for tough jobs.

In addition, Active Hold Control allows you to stop on a hill without applying the brake, increasing comfort and safety on slopes.

STEPLESS SPEED CHANGES

With the easy-to-use CVXDrive, even inexperienced or seasonal operators can get in and get going with little training. Enjoy the comfort of stepless operations and optimal transport at reduced engine speed.

FUEL EFFICIENCY THANKS TO APM, NO MATTER THE JOB

The APM automatically controls the tractor's speed depending on the optimal engine speed and gear ratio. The system makes sure you are always operating in the most efficient range.

ECODRIVE SPLIT THROTTLE

The ECODRIVE manual throttle allows the driver to preselect minimum and maximum engine speeds, adjusting engine speed range to the work at hand.

ADVANTAGES

- 4 mechanical ranges with automatic range change
- 100% of mechanical power is available below 10 km/h for heavy pulling applications
- Active Hold Control keeps the loaded tractor stationary on hills without applying the brakes
- Low engine speed at high ground speed saves transport costs
- Maximum comfort with stepless operations

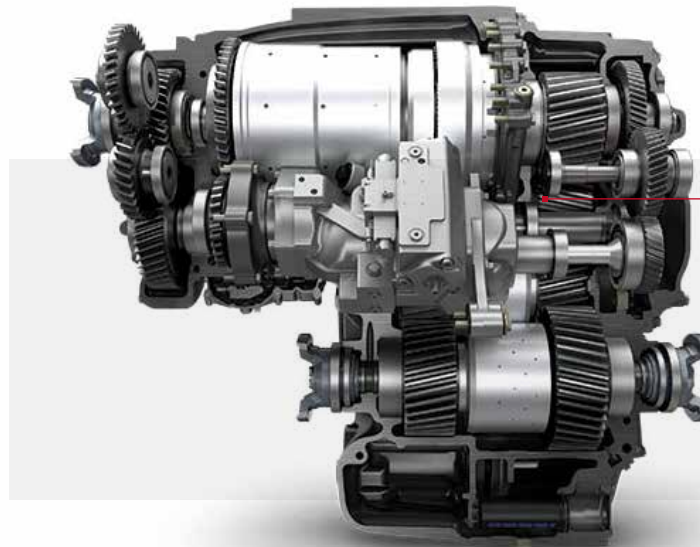

**WORLD'S
STRONGEST
TRACTOR WITH
CVXDRIVE**



An aerial photograph of a field, showing a mix of brown and tan soil. A prominent horizontal red band runs across the middle of the image, serving as a background for the text.

HANDLING EVERY SITUATION

Get the most from your fields

In modern farming, the focus is on using powerful implements in the most efficient and economical way possible. The Quadtrac and Steiger AFS Connect series has the high-performance hydraulic system to meet these expectations. A range of configuration options can be tailored to your specific needs. With up to eight hydraulic remote valves and an impressive oil flow, these machines easily handle the biggest implements in the industry.

HANDLE THE MOST DEMANDING IMPLEMENTS

Get the job done – with impressive capacity and excellent oil flow

Quadtrac and Steiger tractors can be customised for your operation thanks to a large range of hydraulic and drawbar options. You'll be impressed by the high performance these tractors bring to the field - not just in terms of lifting power, but also pulling power - the perfect prerequisites for using heavy implements in all kinds of conditions.

LEGENDARY STRENGTH

Quadtrac tractors are impressive machines throughout and their hydraulic system is no exception: up to 428 litres per minute flowing into up to eight hydraulic remote valves, and up to 9071 kg of hitch lift capacity. The optional PTO, which achieves 1000 rpm at an engine speed of 1900 rpm, delivers full power where you need it.

COLOSSAL OIL FLOW

Quadtrac and Steiger tractors use a second hydraulic pump to provide exactly the required oil flow to each of eight remote valves. It allows the PTO and a second pump to run simultaneously on the same unit for implements requiring high oil flow. This Twin Flow system can be converted to parallel flow system by inserting one simple plug supplied with the tractor.

WELL-EQUIPPED

The Power Beyond system installed in Quadtrac AFS Connect machines has a load sensing device which activates flow and pressure as required.

YOU'VE NEVER HAD SO MUCH FREEDOM

The controls for the remote valves set a new standard in configurability and comfort. Use the high definition AFS Pro 1200 monitor to assign up to 4 remote valves to hot keys on the Multicontroller, or to the rear control units. The backlit toggle switches change colour depending on which remote valve has been assigned to them - another Quadtrac/Steiger first.

ADVANTAGES

- 9,071 kg of hitch lift capacity
- Configurable remote valve controls
- Fully independent PTO system
- Up to a massive 428 l/min flow for high-demand implements
- Perfect visibility to the drawbar pin allows easy implement connection



Shortcut keys bring you directly to the settings menu to configure your remote valves.



Configurable control switches with changing colours allow individual assignment of the rear control units

NEW ELECTROHYDRAULIC REMOTE VALVES

The Quadtrac and Steiger AFS Connect are equipped with new electrohydraulic remote valve assemblies which increase the hydraulic power curve by 17 bar. Special spring-loaded covers protect against dust and are designed to make the hydraulic connection a one handed job. Also, a lever for each remote valve makes coupling and uncoupling easier. Just lift the lever to couple or release.

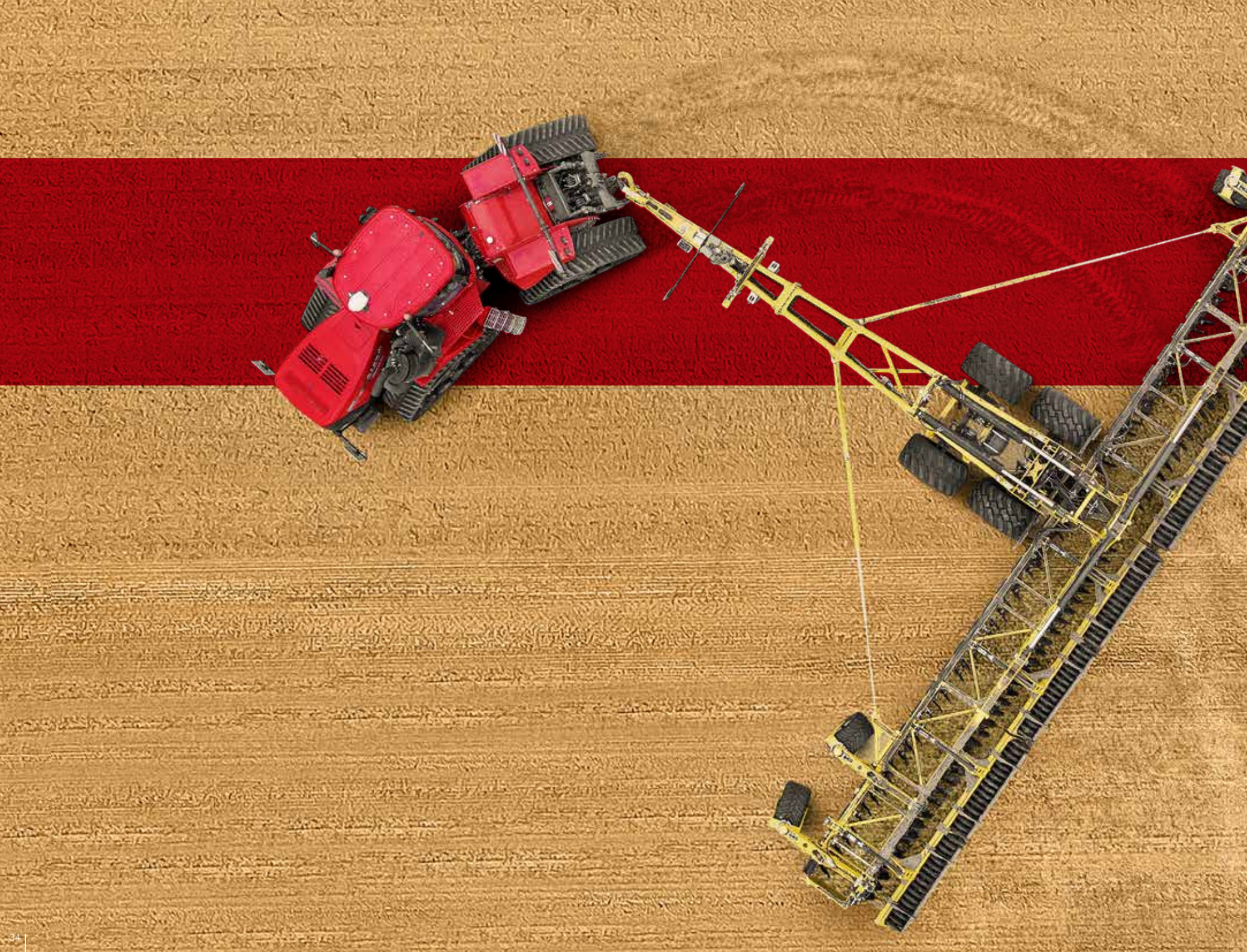



UNEQUALED DESIGN

A track record of excellence

The Case IH Quadtrac AFS Connect features four individually driven, positive-drive oscillating tracks. Each track puts five axles on the ground, so it can bend and flex gracefully, maintaining constant contact for a great ride, optimal in-row ground pressure, superior flotation and better traction. That ground contact, even on the toughest terrain, isn't just fancy engineering – it's real performance for tough conditions and maximum productivity.

Moreover, the undercarriage is maintenance-free with on-the-go track self-tensioning and clear bearing caps for easily checking fluid levels.

ONE STEP AHEAD

Design you can only get from Case IH

When Case IH launched the Quadtrac in 1997, it was like nothing else on the market. With an efficient blend of tracked drive units and articulated steering, we overcame the key problems associated with twin-track tractors, such as soil scuffing on headlands and loss of power while steering.

TOP-SPECS CHASSIS

Quadtrac and Steiger tractors have long featured a frame built of 13 mm thick steel and a long wheelbase with built-in weight for better traction to fulfil any task's demands. Every detail is thought through and built with extra strength in mind.



TRI-POINT OSCILLATION

The centre section of the Steiger chassis features a large top link that extends from the front frame to the very back of the rear frame to transfer dynamic loads more efficiently. This type of tri-point oscillation chassis design provides greater pulling power when compared with pulling a load through a gudgeon bearing.

INNOVATIVE CENTER PULL DRAWBAR

Maximum traction is achieved with the use of a centre-pull drawbar. It is directly connected to the main articulation joint to provide superior traction with direct load transfer to the front frame without stressing the rear axle and frame.



TWO BASIC CHASSIS SIZES FOR THE CONFIGURATION TO SUIT YOUR OPERATION:

2.997 M WIDE
WITH 30" RUBBER TRACKS

2.55 M WIDE
WITH 710 TYRES

3.015 M WIDE
WITH 36" RUBBER TRACKS

2.70 M WIDE
WITH 800 TYRES

QUADTRAC CHASSIS: UNDER 3 M OVERALL WIDTH



Total soil contact at all times.*

Tri-point Oscillation provides rigidity and strength for heaviest application.*

* For illustration purposes only.



ADVANTAGES

- Load stress is distributed through to the front frame
- Durability, strength and stability are greater than alternative designs
- Traction is increased and slip reduced
- Ground contact is retained at all times
- 26° up and down oscillation

26°
LONGITUDINAL
OSCILLATION

LEGENDARY 4-TRACK DESIGN

More than 20 years of track technology leadership

AUTOMATIC TENSIONING

The self-adjusting tracks keep you up and running, without manual track tensioning and adjustments.

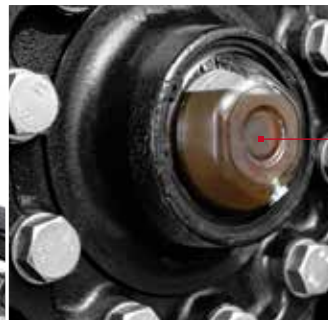

Case IH track technology innovation goes back to 1997 with the introduction of our Steiger Quadtracs. We've expanded on this with the introduction of the Steiger Rowtrac, Magnum Rowtrac and even a track option on the Axial-Flow Combine. If you are searching for a maximum flotation, early field access and less soil compaction, the Case IH tracks are made for you.

BE THE FIRST IN THE FIELDS

Case IH tracks are adapted to all field conditions without slippage between the drive wheel and the track to maintain positive drive at all times. Getting in your field sooner after the rain is another great way to improve efficiency and return on investment across your farm.

NO TIME FOR DOWNTIME

The tracks are designed with a clear view port on the 10 hubcaps for quick and easy daily service.

PROTECT YOUR RESOURCES

Quadtrac's weight and big implements are constantly evenly distributed over a footprint of 5.6 m² to lower soil pressure, reduce compaction and improve flotation. It results in minimal soil disturbance, a smooth ride and less stress on your fields.

The three roller pair system reduces spacing between the wheels and gives the weight of the tractor even more support to protect your soil.

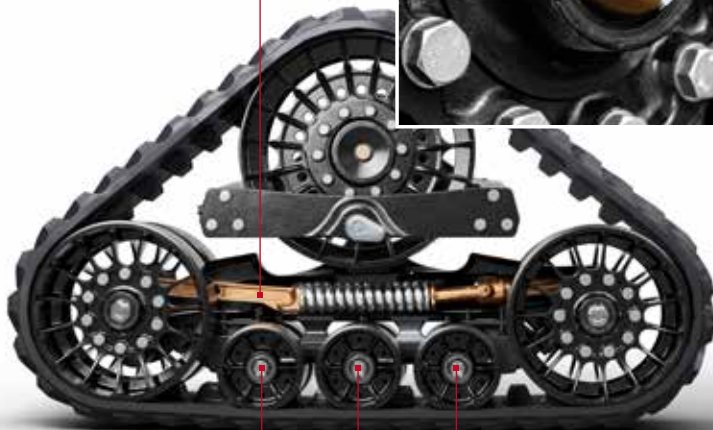

RUBBER-DAMPENED OR SUSPENDED TRACK SYSTEM

THE SECRET IS IN THE DETAILS: THE OUTER IDLERS ARE POSITIONED HIGHER THAN THE ROLLERS. THIS ENSURES MAXIMUM SOIL PROTECTION WHEN TAKING CORNERS, AND REDUCES WEAR WHEN DRIVING ON THE ROAD.

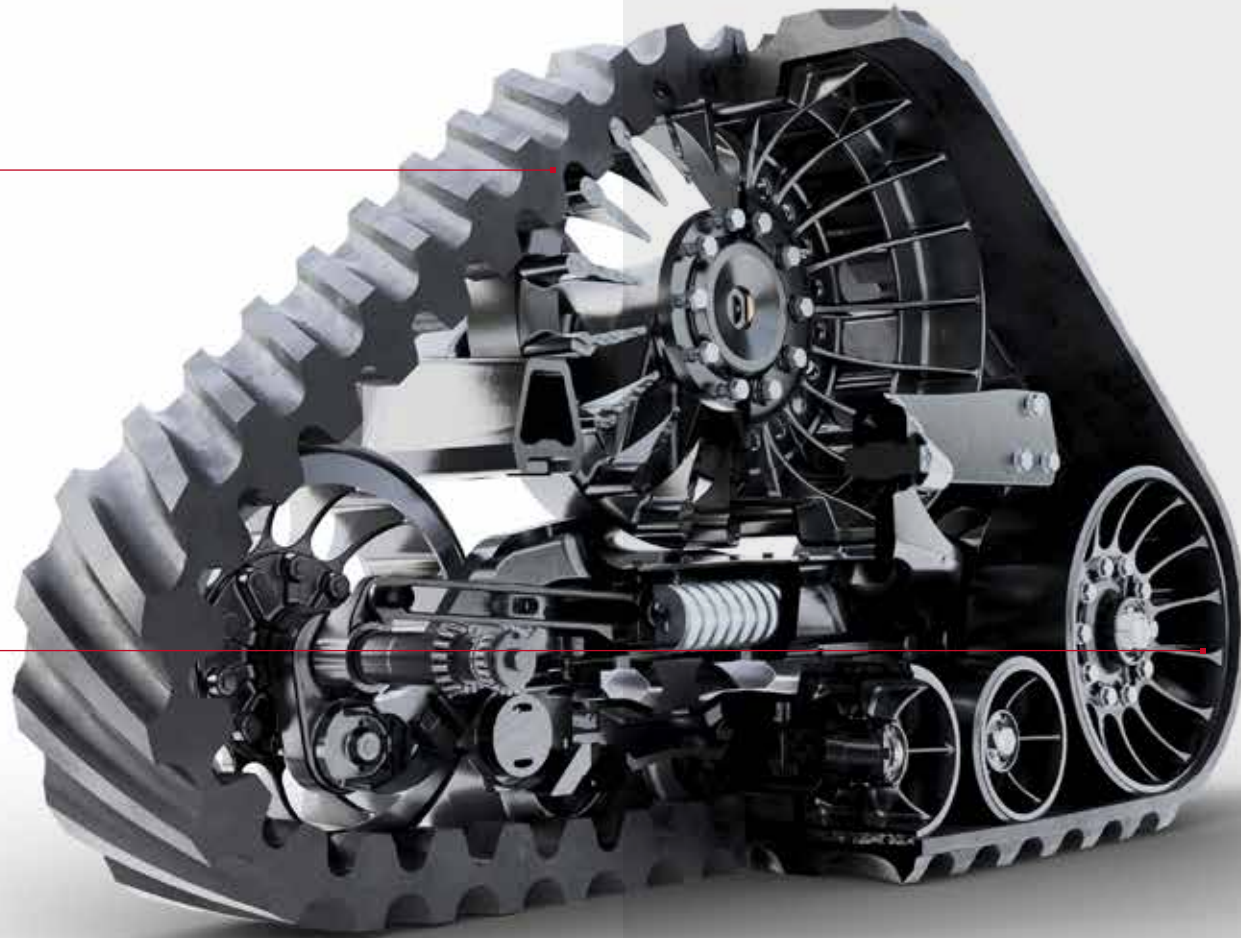

ADVANTAGES

- Damped roller pairs allow perfect adaptation to uneven ground
- Spoke idler wheels eject debris from inside and outside
- Tracks automatically tensioned by hydraulic pressure
- Footprint of 5.6 m² to protect resources
- Easy maintenance with clear hub caps
- Long service interval of 1800 hours

LET'S REDUCE PRESSURE

AS A COMPARISON, QUADTRAC SOIL COMPACTION
IS ONLY 0.5 KG/CM² (28.000 KG / 56.000 CM²),
THE SAME AS A PERSON ON 1 LEG (100 KG, 200 CM²=0.5 KG/CM²).





PERFECTLY MANAGED POWER

Reduce soil compaction and slip

DYNAMIC LOAD



50%

50%

With dynamic weight transfer during pulling, the weight distribution between front and rear axle is equal.

STATIC LOAD



40%

60%

The static weight distribution on a Quadtrac 620 is 40% on the rear axle and 60% on the front axle.

Case IH Quadtrac models have set the industry standard for tracked-tractor performance in every category, ranging from superior ride comfort to efficient steering performance under load. The Quadtrac's four individually driven oscillating tracks, articulated steering and other innovative designs are the backing behind that claim.

POSITIVE DRIVE MEANS DURABILITY AND RELIABILITY

These tractors deliver more usable power you can depend on because of the exclusive Quadtrac positive-drive design. Lugs that interlock with bars on the wheel eliminate slippage between the drive wheel and the track – a positive drive is continuous at all times, even in a wet or slippery spot.

PERFECT WEIGHT DISTRIBUTION

Axle loads of less than 10 tonnes/axle can keep compaction within the top few cm of the soil. Poorly-designed heavy equipment can cause deep compaction, resulting in permanent yield reduction over time. Even weight distribution helps to minimise ground pressure, while adding more axles reduces the effect of soil compaction.

Each Quadtrac track uses five independent axles (two idlers and three roller wheels) helping to better distribute the axle loads of increasingly larger equipment. This results in even distribution of the load placed upon the tractor, and helps create an overall footprint of 5.6 m².

TRACTION AT ITS BEST

The four tracks of a Quadtrac distribute weight more evenly and efficiently than two-track systems, limiting compaction. This leads to numerous other benefits, including better flotation, traction and easier transport. That's because in each track unit, the load is distributed evenly across the length of each track, even when the tractor is at work and additional load is being placed on the rear tracks.

KEY FACTS

- 5 axle design for perfect weight distribution
- 3 roller wheels keep constant tension and reduce reverse flex effects
- Axle loads of less than 10 tonnes/axle



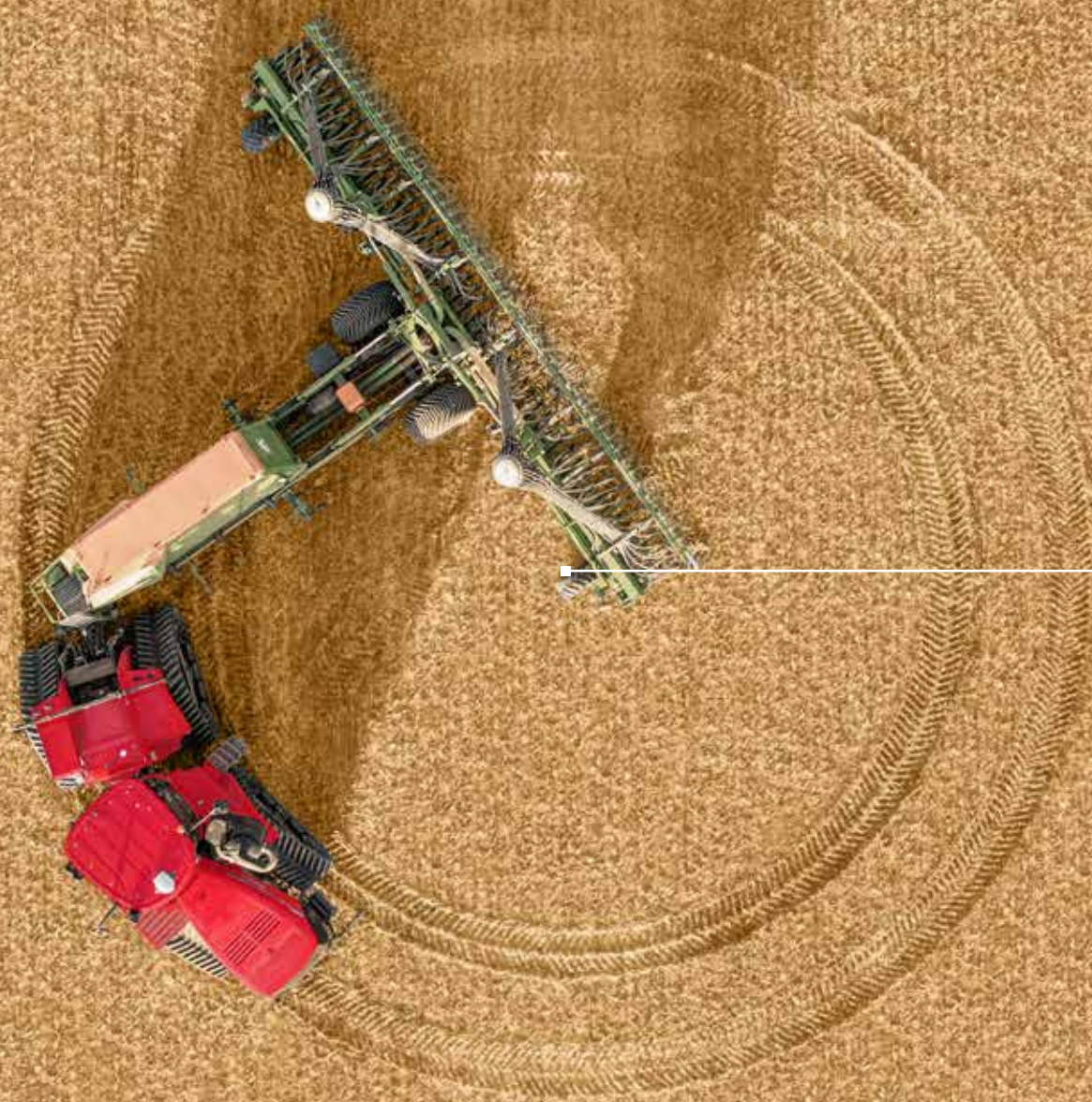

**5.7 M MINIMUM
TURNING RADIUS**



FULL CONTROL – ON EVERY STRAIGHT AND IN EVERY BEND

From the pioneers of pivot-steer tracked tractors



Case IH pioneered articulated steering in high horsepower rubber-tracked tractors, adopting the same proven technology used in generations of Steiger tractors.

POWER UNDER CONTROL

Whether tracked or wheeled, these tractors steer in exactly the same way. True articulated pivot steering means no skid turns, and all four corners of the tractor remain on the ground, with equal torque transferred during turning.

They manoeuvre under load with no loss of traction, unlike twin-track systems that disrupt power transfer during turning. Plus, Quadtrac steering remains easy and positive under all conditions. It provides a full articulation angle of 42° even with duals mounted.

DIFFERENTIAL LOCK

With the differential lock engaged, the wheels or tracks are locked together, eliminating slippage between the left and right hand side of the tractor in wet or slippery conditions. When engaged, you do not have to worry about getting through tough spots in the field.

EFFICIENT AXLES

Produced in-house, the axles are designed to meet the requirements of the tractor chassis and engine horsepower, providing maximum traction at all times with little to no operator effort.

ADVANTAGES

- Articulated pivot steering means no loss of power
- Full articulation angle of 42° allows 5.7 meters turning radius even with duals mounted
- No slippage with differential lock engaged means reduced fuel consumption



In comparison to a 2-track-system, the 4-track-system steers under full loads minimizing soil disturbance when turning.



Slip
3%

Engine Power
91%

A series of floating windows displaying data tables and a map. The windows are semi-transparent and appear to be part of a digital interface overlaid on the scene.

SMART, COST-EFFICIENT AND ECO-FRIENDLY

Case IH Advanced Farming Systems (AFS™)

As one of the leading agricultural manufacturers of precision farming technology, Case IH offers a range of applications that combine information input and the unique AFS Connect telematics portal into a goal-oriented data management system for registered machines. This pioneering role is underlined by value-adding features such as the latest Advanced Farming System (AFS™), full ISOBUS compatibility and the HMC II headland management system.

The HMC II has been improved, letting you automate more and more of the tractor's operations. With repeatable accuracy, reduced overlaps, lower operating costs, and maximisation of profits, AFS ensures both precision and success.



Ground Speed
6.0 km/h

Engine Power
54%

Coverage Area
26.3 ha

Fuel Rate
89.3 l/h

CASE IH AFS™

Take advantage of maximum precision – day in and day out

Case IH Advanced Farming Systems (AFS™) have been at the forefront of precision farming for more than a decade. Case IH AFS tools include everything you need to achieve repeatable accuracy down to 1.5 cm, reduce overlaps, cut operating costs and maximise your profitability.

INDUSTRY-LEADING PRECISION

The new Quadtrac / Steiger AFS Connect is equipped with three new system components which enable you to configure precision farming functionality and tractor systems the way you want them:

- AFS Pro 1200 LCD display: designed for intuitive navigation, the remote display viewing connects operators with farm managers seamlessly, and Bluetooth® capabilities pair the display with a mobile phone.
- New AFS Vision Pro operating system: enables you to configure precision farming functionality, tractor systems and connectivity to your operating preferences.
- AFS Vector Pro receiver: streamlines guidance correction options, ranging from base (WAAS and AFS 1) to medium (AFS 2) to high (RTK and AFS RTK+) accuracy levels.



RTK+ 1.5 CM ACCURACY LEVEL

AFS RTK+ is a cellular-based correction guidance that allows producers to easily achieve repeatable accuracy down to 1.5 cm, reduce overlaps and cut input costs and maximise your yield potential. Thanks to RTK Fill, signal losses can be bridged for up to 20 minutes as soon as the machine starts up. Just keep going without interruption – and maintain ultimate precision.

ALWAYS ON TRACK WITH ACCUGUIDE

The fully-integrated AccuGuide guidance system helps you complete your field work and improve your agronomic performance. It ensures pass-to-pass accuracy and reliability, regardless of the season, operation or patterns (field, circle, curved, heading, spiral and straight) to reduce overlaps and skips.

ADVANTAGES

- Range of signal accuracies available (WAAS, EGNOS, OmniSTAR, RTX and RTK signals)
- Receivers use GPS, Galileo, BeiDou and GLONASS to increase uptime in challenging environments
- Optional high accuracy RTK+ signal with accuracy levels close to 1.5 cm
- Integrated Accuguide auto-guidance for Quadtrac and Steiger AFS Connect
- RTK Fill bridges RTK+ signal gaps of up to 20 minutes





AFS CONNECT

Freedom to farm the way you want



AFS Connect lets you remotely monitor and manage your farm, fleet and data, allowing you to optimise your performance, productivity and flexibility. Efficiently visualise your equipment with little to no idle time. With all the information at your fingertips, you can successfully manage your operations anytime, anywhere!

USER-FRIENDLY INTERFACE

- New, intuitive and redesigned interface with all information at your disposal
- Ergonomic platform divided into 3 sections: fleet, farm & data

TIME-SAVING MANAGEMENT

- Visualisation of data from multiple machines in one field
- Manage your activity & transfer data from your office to machines and vice versa

MAXIMUM PRODUCTIVITY-ENHANCING DECISION MAKING

- Notifications & visualisation of critical operating parameters
- Connect and share securely with Application Programming Interface (API)



Go anywhere, see everything

RECEIVE UPDATES ON YOUR DAILY OPERATIONS

- See, share and manage data on the go, in real time, from any device
- View updated machine telematic data and fault codes remotely

THE ULTIMATE SOLUTION FOR WHEN YOU'RE ON THE MOVE

- Live vehicle map lets you find machines' locations and get driving directions
- Share vehicle info, location and directions with various apps (e.g. WhatsApp) on your phone



YOUR ALL-NEW DESTINATION FOR CASE IH PRODUCT SUPPORT

MYCASEIH is a new free cloud-based platform which gives you a single place to log in for access to everything related to your Case IH farm equipment. Find an overview of all your machine and equipment, manage your users and access a support knowledge section with operator manuals, support documents, parts catalogues and more. The platform is available on all devices: smartphone (Apple & Android), tablet and desktop.

VISIT US AT MY.CASEIH.COM





FARM MANAGEMENT

GET MORE DONE EACH DAY

Optimise your time by easily organizing your fields, applications and agronomic data

MANAGE YOUR COMPANY

Managing your fields and your data can be time-consuming. AFS Connect optimises your time by easily organising your fields, applications and agronomic data.

With a wealth of information at your fingertips, you can boost your operation's performance.

- **Data visualisation:** access agronomic data in near real-time for all your seeding, application and yield activities. Included: topographic, weather, equipment, or prescriptions information.
- **Reporting:** capture all of your critical farming information on the go or directly from your equipment. Plan upcoming activities, manage logistics, share data with your trusted advisors and make informed decisions
- **Usability:** Keeping track of everything going on in your operation has never been easier. Whether you're on the road, in the field or at the office, the intuitive user interface keeps you informed.

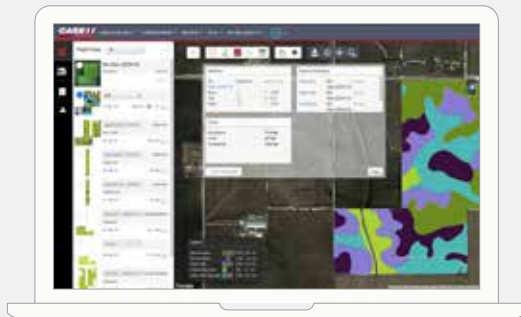

FLEET MANAGEMENT

TRACK, MONITOR & MANAGE YOUR ENTIRE FLEET

Efficiently track your equipment's location & view machine parameters in real time

MANAGE YOUR PRODUCTIVITY

When all your equipment operates efficiently with little to no idle time, you have the peace of mind that comes with working smarter and knowing that you're doing all you can to make the most of each growing season.

- **Fleet overview:** access key information with detailed performance values for each machine by vehicle type. The map overview allows visualisation of connected equipment to more efficiently execute infield operations and coordinate the fleet.
- **Vehicle details page:** access recent machine operations and get a 7 day report of the vehicle status by hours and fuel usage.
- **Alerts history and notifications:** view and filter the faults shown to the operator on the in-cab displays. Configure and setup notifications such as vehicle speeds, oil temperature, engine load or fuel level and receive them via web or via text messages.



DATA MANAGEMENT

CONNECT AND SHARE DATA

Securely share your farm data with trusted partners, anytime, anywhere

MANAGE YOUR DATA EXCHANGE

Seamlessly manage, share and move data – all while ensuring you stay in complete control with your preferred trusted business partners.

- **Secure data sharing:** Securely share selected data with trusted partners while keeping complete control over who can access each piece of generated data.
- **Third-party partners:** wirelessly transfer two-way data between AFS Connect and trusted third-party suppliers (AgDNA, Cropio, Farmers Edge™, Trimble® Ag Software, Climate Field View..) to make the most of agronomic data and drive daily management decisions

Solutions for mixed fleets: Case IH customers benefit from a comprehensive solution for sharing data thanks to two recent partnerships:

- DataConnect is a new cloud-to-cloud interface, in partnership with CLAAS, 365FarmNet, John Deere and New Holland. Mixed-brand fleets owners can look forward to easier data exchange and management without compatibility issues.



- With the universal data transfer hub Agrirouter (including many other tractor and implement brands like AGCO, SDF, Krone, Pöttinger, Lemken, Kuhn, etc., list available at <https://my-agrirouter.com/en/agrirouter/brands/>) to help ensure compatibility of tractor and implement data management systems.

FULL REMOTE SUPPORT

Productivity and connectivity made easy

Sometimes, life gives you moments you can't afford to miss. Whether that's at the ballfield or simply joining the family around the dinner table, AFS Connect helps put you where you want to be. You don't need to be in the cab to see exactly what the operator is seeing.

With the new AFS Pro 1200 monitor, you are able to utilize remote display viewing capabilities, remotely diagnose maintenance and service issues and receive machine software updates automatically.

REMOTE DISPLAY VIEWING

No matter where they are, a farm manager or dealer can easily see exactly what the operator is seeing on the screen in the tractor cab.

REMOTE SERVICE SUPPORT

There's no time for downtime. Now, you can work with your local Case IH dealer to remotely diagnose maintenance and service issues and identify the parts you need to stay up and running.

ADVANTAGES

- Keep operators in the field and in the cab
- Optimise your time
- Better and more-informed management decisions

FIRMWARE OVER THE AIR (FOTA)

Your dealer can update your operating firmware wirelessly, giving you the advantage of new features, functionality and enhancements.



GET THE MOST OUT OF YOUR TRACTOR

HMC II headland management and AccuTurn Pro plus integrated ISOBUS compatibility

HMC II – AUTOMATED HEADLAND TURN

Quadtrac models feature Headland Management Control II, which is designed to assist the driver when turning at the headland. Each step can be programmed either by time or distance travelled. In addition, triggers for various other automated functions can be set, such as lowering the engine speed after lifting the implement. A headland sequence can be recorded while driving or programmed on the stand. The sequence can be played back manually or automatically via the the Multicontroller or the AFS Pro 1200 monitor.

ISOBUS CLASS III – OPTIMIZED FEED RATE

With ISOBUS III, an implement can easily be controlled directly from the AFS Pro 1200 monitor. With ISOBUS III, the implement automatically controls aspects of the Quadtrac / Steiger. The tractor will automatically adjust forward speed, steering (option), hitch position and PTO

speed, as well as operating remote valves depending on the implement's needs. The result is perfect cooperation and efficiency of the implement and tractor.

ACCUTURN - SMART HEADLAND TURNS

The system is fully customizable, so that you can choose between multiple turn triggers, choose to turn early or late, skip up to 12 swaths or to customise the turn path to optimize implement positioning for re-entry when using trailing implements with a long hitch.

Besides reducing skips and overlaps, it ensures your implement is square after every turn to provide the greatest agronomic benefit for your plants' growing environment

While enhancing your vehicle's turning accuracy, Accuguide's integrated guidance system helps cut fuel and labor costs which results in an increased overall productivity. The Accuguide option selection is required

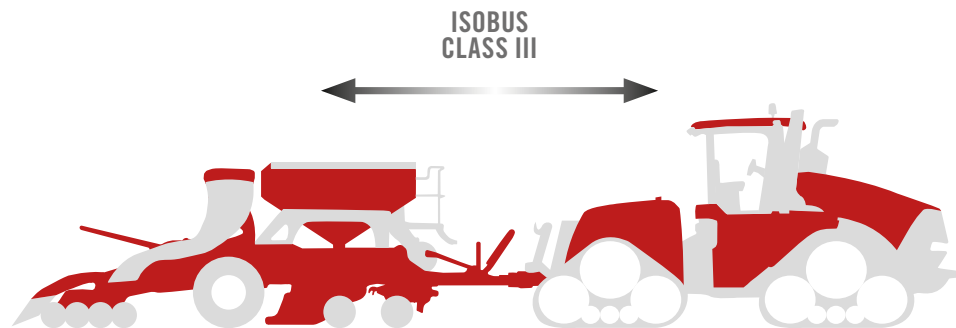

ADVANTAGES

- Headland Management Control II automates workflows for less driver fatigue and higher productivity
- ISOBUS III optional for best efficiency: the attached implement controls, for example, tractor speed, steering (option), hitch raise/lower and PTO speed.
- AccuTurn Pro combines automatic steering and headland turning functions for complete automation



620

AFS

C
QU



BE A FARMER

We take care of the rest!

At Case IH, we see it as our responsibility to be at the customer's side anytime he or she has a question. Our intensive after sales support includes a comprehensive service package and customer service programme, which has the answer to any question. A strong local network allows us to be close to you when you need us.

Quadtrac/Steiger's highest quality components are designed for long hard hours as well as reducing maintenance to a minimum - and they help preserve your machine's value to boot. All inspection points can be accessed from the ground, making checking the condition of your machine easier than ever. Even the engine compartment has been designed with accessibility in mind and can be inspected from both sides. If there should ever be an issue, Case IH offers comprehensive service packages. Our service partners are at your side with original spare parts when and where you need them.



Safe and comfortable, that's how we've designed the Quadtrac. You can easily access to the right-hand side of the cab with the ladder.



WE HELP – YOU KEEP FARMING!

Servicing made simple

DAY-TO-DAY SERVICE HAS NEVER BEEN EASIER.

We know that in this business time is critical, and the less you need to spend on servicing the better. Daily maintenance on Quadtrac and Steiger tractors are straightforward, easy and quick in order to reduce costs and machine downtimes.

600-HOUR OIL CHANGE INTERVALS

Industry-leading oil service change intervals help keep you in the field longer.

GROUND-LEVEL FLUID CHECKS

All daily maintenance tasks can be carried out without tools and done from a single location near the cab entry.

MAINTENANCE FREE AFTER-TREATMENT SYSTEM

Exclusive patented HI-eSCR2 technology requires no engine regeneration or additional emission components, reducing maintenance and costly downtime to a minimum.

EASY ACCESS TO THE FUEL FILTER

The filter is located on the lower right-hand side of the engine compartment to improve serviceability and access.

LARGE ADBLUE TANK

With a large fuel tank of 322 liters, it guarantees long working days without refilling.

AIR FILTER AND DUST EJECTOR

The air filter with spin tube pre-cleaner and dust ejector will make sure to prevent the entrance of dirt into the engine.

BEST IN CLASS COOLING PACKAGE

Front fold down coolers are designed for easy cleaning.

QUICK BATTERY ACCESS

You can access directly and easily the battery compartment without tools – no need to unscrew any service cover.



SERVICE TEAM

Be a farmer. We take care of the rest

The Case IH SERVICE TEAM, a strong dealer network backed up by local Case IH market teams, industry-leading Case IH support tools, modern training methods, best-in-class spare parts support and logistics performance: these provide Case IH customers with excellent all-encompassing after-sales service, keeping you farming!

GENUINE PARTS

WE KEEP YOUR EQUIPMENT RUNNING

Your local Case IH dealer and our dedicated 24/7 parts call centre technicians and their logistics colleagues are all part of the Case IH ServiceTeam network. They're highly trained to give you expert advice and solve problems, ensuring the correct, genuine Case IH parts are located and dispatched right away, reaching you next day or sooner to keep your machine in top condition.



MAXSERVICE

AROUND THE CLOCK. AROUND THE COUNTRY.

When you're working around the clock, MaxService ensures you're never alone. It's a dedicated helpline that connects you to the Case IH ServiceTeam 24/7. Call technicians at your local dealer are ready to assist with technical advice, software solutions and genuine parts ordering. At peak season, we can keep you farming with breakdown assistance.



SAFEGUARD WARRANTY

SAFEGUARD THREE-YEAR WARRANTY

The best things come in threes: Our extremely high quality standards and continual improvements to our products have allowed us to offer a 3-year factory warranty. The warranty covers all necessary repairs in years 2 and 3 to the extent of the base warranty. Labour and Case IH original parts are covered for every warranty repair without any unexpected cost to you. Terms and conditions apply, call your local Case IH dealer for details!



OPTIMAL FINANCING SOLUTION FOR EVERY INVESTMENT

CNH Industrial Capital is the financing company for Case IH. Our employees are financial experts and have many years of experience in agriculture. We not only know about Case IH products and the market – we also understand the individual requirements of your operations. Therefore we are always able to offer you a financial solution for your new investments that is tailored specifically to your operational requirements. Our most important goal is improving the profitability of your investments!



SUSTAINABILITY

It's part of everything we do



REDUCE THE CONSUMPTION OF RESOURCES BY MOVING FROM FOSSIL FUELS TO A **RENEWABLE ENERGY SYSTEM**



INCREASE AGRICULTURAL PRODUCTIVITY TO **IMPROVE FOOD** AVAILABILITY



REDUCE **ENVIRONMENTAL IMPACT** AND OPTIMISE **ENERGY CONSUMPTION** IN ALL COMPANY PROCESSES



INCREASE OPPORTUNITIES FOR EXCHANGING **IDEAS** AND **GOOD PRACTICES** WITH ALL **STAKEHOLDERS**

Case IH is part of CNH Industrial, one of the world's largest capital goods companies. It has a firm focus on its environmental responsibilities, and has been a nine-time leader in the Dow Jones Sustainability Index.

WITHIN THE CNH INDUSTRIAL GROUP:

- 91% of waste is recovered
- 27.5% of water used is recycled and
- 56% of electricity used is from renewable sources.

Being a global leader in capital goods carries great responsibilities, which means that we must be accountable for every global activity we perform. Our responsibility does not stop at the factory gate, and we have made great efforts to be proactive when it comes to the broader global issues surrounding sustainability. Over the years, our work in research and

development has been geared towards ensuring that our products continue to achieve increasingly high standards in terms of safety and eco-compatibility. Rather than limiting customers to a choice between low operating costs and eco-efficiency, our strategy is to offer products that deliver both.

By providing innovative products and solutions that abide by environmentally responsible operating practices, Case IH is doing its part to address global issues such as climate change. Today's companies face complex and interconnected challenges that demand an ever-evolving approach to sustainability, a scenario that Case IH believes is an important driver in creating long-term value for all its stakeholders, which is a core objective of the brand.

At Case IH, our engineers are focused on producing machines that not only work on the land, but work with it too.

SUSTAINABILITY GROWTH DRIVERS

- Necessity of feeding an increasing population
- Importance of soil protection for future generations
- Growing sustainable farming solutions
- Increasing public awareness
- Fostering engagement



MODELS	STEIGER 420 / STEIGER 420 CVX	STEIGER 470 / STEIGER 470 CVX	STEIGER 500 / STEIGER 500 CVX
ENGINE			
Type		FPT Cursor 13	
Number of cylinders / number of turbochargers		6 / Single Stage Turbo	
Emission level		Stage V	
Capacity (l)		12.9	
After treatment		Hi-eSCR2 - high efficiency SCR system	
Rated power ECE R120 2) [kW/hp(CV)]	313 / 426	350 / 476	373 / 507
Rated power ECE R120 2) Power Management [kW/hp(CV)]	345 / 469	386 / 525	410 / 558
Rated engine speed (rpm)		2,100	
Maximum power ECE R120 2) [kW/hp(CV)]	343 / 467	380 / 517	403 / 548
Maximum power ECE R120 2) Power Management [kW/hp(CV)]	345 / 469	386 / 525	410 / 558
... at engine speed (rpm)		1,900	
Maximum torque (Nm @ 1400rpm)	1,992	2,229	2,374
Torque rise (%)	40	40	40
Fuel tank, diesel/urea (litres)	1,230 / 159	1,230 / 159	1,230 / 250
CHASSIS			
Type		Row Crop Chassis	Row Crop Chassis
TRANSMISSION			
Type		16F/2R PowerDrive or CVXDrive	
Powershuttle		Std.	
AXLES			
Axle drive and gear arrangement		4 planet	Compound, 3 planet
Axle diameter		5" – Flanged or bar	4,5" – Flanged or bar
Axle diff-lock type		Multi disc wet plate with independant front/rear control	
POWER TAKE OFF			
Type		Live independent system integral with transmission	
Speed Option		1,000	
Engine speed (rpm)		1,800	
Shaft type		1 3/4" shaft - 20 spline	
HYDRAULIC SYSTEM			
System type		Variable displacement, pressure and flow compensating (PFC)	
Max. pump flow (l/min)	159	159	159
Optional pumps max.pump flow High Flow/Twin Flow (l/min)	216 / 428	216 / 428	216 / 428
System pressure (bar)	210	210	210
No. of remote valves	4 / 6 / 8	4 / 6 / 8	4 / 6 / 8
No. of remote valves with 3 point hitch	4 / 5	4 / 5	4 / 6
THREE POINT HITCH			
Lift Capacity (kg), through full range, 610mm behind ball ends	8949	8949	8949
Category type	Cat IV-N	Cat IV-N	Cat IV-N
HEAVY DUTY DRAWBAR			
Diameter of drawbar pin-high capacity (mm)	51	51	51
Max. permissible vertical load (kg)	4,989	4,989	4,989
CLASS 5 DRAWBAR			
Diameter of drawbar pin-high capacity (mm)	n/a	n/a	n/a
Max. permissible vertical load (kg)	n/a	n/a	n/a
WEIGHTS			
Standard vehicle weight (kg)	18,600 / 19,350	18,600 / 19,350	18,600 / 19,350
Max. gross vehicle weight (kg)	22,450	22,450	22,450
DIMENSIONS ¹⁾			
Total length (mm)	7,493	7,493	7,493
Total height (mm)	3,937	3,937	3,937
Total width (mm) ²⁾	2,549	2,549	2,549
TRACKS			
Drive	–	–	–
Track width Standard / Option (cm)	–	–	–

MODELS	QUADTRAC 470 / QUADTRAC 470 CVX	QUADTRAC 500 / QUADTRAC 500 CVX	QUADTRAC 540 / QUADTRAC 540 CVX	QUADTRAC 580	QUADTRAC 620
ENGINE					
Type	FPT Cursor 13				
Number of cylinder / number of turbochargers	6 / Single Stage Turbo		6 / Two Stage turbo		
Emission level	Stage V				
Capacity (l)	12.9				
After treatment	Hi-eSCR - high efficiency SCR system				
Rated power ECE R120 2) [kW/hp(CV)]	350 / 476	373 / 507	399 / 543	433 / 589	462 / 628
Rated power ECE R120 2) Power Management [kW/hp(CV)]	386 / 558	410 / 558	451 / 613	476 / 647	509 / 692
Rated engine speed (rpm)	2,100				
Maximum power ECE R120 2) [kW/hp(CV)]	380 / 517	403 / 548	440 / 598	463 / 630	492 / 669
Maximum power ECE R120 2) Power Management [kW/hp(CV)]	386 / 525	410 / 558	451 / 613	476 / 647	509 / 692
... at engine speed (rpm)	1,900				
Maximum torque (Nm @ 1400rpm)	2,229	2,374	2,540	2,757	2,941
Torque rise (%)	40				
Fuel tank, diesel/urea (litres)	1,230 (1,881)/ 322	1,230 (1,881)/ 322	1,230 (1,881)/ 322	1,230 (1,881)/ 322	1,230 (1,881)/ 322
CHASSIS					
Type	Quadtrac Chassis				
TRANSMISSION					
Type	16F/2R PowerDrive or CVXDrive			16F/2R PowerDrive	
Powershuttle	Std.				
AXLES					
Axle drive and gear arrangement	Planetary & drop gear, 3 planet				
Axle diameter	Flanged				
Axle diff-lock type	Multi disc wet plate with independant front/rear control				
POWER TAKE OFF					
Type	Live independent system integral with transmission				
Speed Option	1,000				
Engine speed (rpm)	1,800				
Shaft type	1 3/4" shaft - 20 spline				
HYDRAULIC SYSTEM					
System type	Variable displacement, pressure and flow compensating (PFC)				
Max. pump flow (l/min)	159	159	159	159	159
Optional pumps max.pump flow High Flow/Twin Flow (l/min)	216 / 428	216 / 428	216 / 428	216 / 428	216 / 428
System pressure (bar)	210				
No. of remote valves	4 / 6 / 8	4 / 6 / 8	4 / 6 / 8	4 / 6 / 8	4 / 6 / 8
No. of remote valves with 3 point hitch	4 / 6	4 / 6	4 / 6	4 / 6	4 / 6
THREE POINT HITCH					
Lift capacity (kg), through full range, 610mm behind ball ends	9071				
Category type	Cat IV-N	Cat IV-N	Cat IV-N	Cat IV-N	Cat IV-N
HEAVY DUTY DRAWBAR					
Diameter of drawbar pin-high capacity (mm)	51				
Max. permissible vertical load (kg)	4,989				
CLASS 5 DRAWBAR					
Diameter of drawbar pin-high capacity (mm)	70				
Max. permissible vertical load (kg)	6,804				
WEIGHTS					
Standard vehicle weight (kg)	23,415 / 24,165	23,415 / 24,165	23,870 / 24,620	24,270	24,270
Max. gross vehicle weight (kg)	32,000				
DIMENSIONS ¹⁾					
Total length (mm)	7,613	7,613	7,613	7,613	7,613
Total height (mm)	3,835	3,835	3,835	3,835	3,835
Total width (mm)2)	2,997	2,997	2,997	2,997	2,997
TRACKS					
Drive	4 independent tracks, positive drive				
Track width Standard / Option (cm)	76 / 91	76 / 91	76 / 91	76 / 91	76 / 91

Free phone: 00 800 22 73 44 00

 Safety never hurts! Always read the Operator's Manual before working with any equipment. Inspect equipment before using it, and be sure it is operating properly. Follow the product safety signs, and use any safety features provided. This literature has been published for worldwide circulation. The standard and optional equipment and the availability of individual models may vary from one country to the next. Case IH reserves the right to undertake modifications without prior notice to the design and technical equipment at all times without this resulting in any obligation whatsoever to make such modifications to units already sold. Whilst every effort is made to ensure that the specifications, descriptions and illustrations in this brochure are correct at the time of going to press, these are also subject to change without prior notice. Illustrations may show optional equipment or may not show all standard equipment. Case IH recommends **AKCELA** lubricants.

