



RANGE OF STUBBLE CULTIVATORS

Versatility and reliability are the features which distinguish TERREMOTO 2, TERREMOTO 3 and DRACULA HYDRO minimum tillage machineries. They are both characterised by their high ground clearance and broad spacing between work tools so that the soil and residue flow quickly to avoid the risk of clogging. The hardened steel chassis allow direct use on hard ground to perform several tasks in a single pass. In this way, TERREMOTO 2, TERREMOTO 3 and DRACULA HYDRO provide maximum adaptability to different ground and crop conditions for total use all year round.

DRACULA HYDRO 430

AGRONOMIC BENEFITS



Incorporation of residues

Timely burial of residue plays a fundamental role in activating organic substance decomposition processes and reducing pathogen levels in the soil. Remixing soil and organic substance (top 15 cm) promotes microbial activity in the soil, thereby ensuring better supply of nutrients available for the next crop cycle.

Breaking up work strata

Breaking up the soil being worked ensures correct development of roots, facilitates water drainage and soil aeration, thereby improving crop resistance to biotic and abiotic stress.

Preparing the seed bed

The final stage in tillage is the creation of the seed bed. Level and well refined soil is fundamental in ensuring good quality work by the seed drill.

TERREMOTO 2 Stubble cultivator	4
TERREMOTO 3 Stubble cultivator	4
DRACULA HYDRO Combined cultivator	14



AGRONOMIC BENEFITS



Versatility in use

Ideal for soil preparation for winter & spring crops (high moisture) as well as fast preparation of the soil for a second harvest (dry + residue).

Efficiency

Operations focused in a single pass for lower operating costs.

Performances

High work speed (8-12 km/h).

Reliability

Sturdy chassis and the use of high quality materials for extended working life.

TERREMOTO 2 e 3 Stubble cultivators



TERREMOTO 2 300

CUT YOUR OPERATION COSTS: TRY THE DIFFERENCE!

TERREMOTO 2 introduces MASCHIO GASPARDO category of stubble cultivators. Characterised by a sturdy fixed-type frame, its working type follows the principles of “Minimum Tillage” thanks to the two ranks of tines that work in combination with the discs and the rear roller. The extreme compactness that features an overall length under 3 metres, together with the combined action of several working parts allow TERREMOTO 2 to operate in special conditions such as hilly or uneven terrain, guaranteeing good soil refinement.

TECHNICAL DATA CARD



Chassis	Fixed (TERREMOTO 2)			
Model		250	300	350
Power	HP	90-140	100-160	110-180
Working width	m	2,5	3	3,5
Transport width	m	2,5	3	3,5
Working depth	cm	25	25	25
Number of tines	n°	6	7	7
Distance between ripper tines	cm	73	73	73
Weight*	kg	1052-1250	1198-1464	1261-1551

*Non stop/bolt version with roller cage Ø 450 mm

COMPACT CULTIVATOR

The action of different working parts, together with its extreme compactness, make TERREMOTO 2 the ideal machine for farms with small to medium-sized plots of land and equipped with medium to low-power tractors.



TERREMOTO 3 300

TERREMOTO 3: TOP-RANKING CULTIVATOR

TERREMOTO 3 represents the top of the category of MASCHIO GASPARDO stubble cultivators. Characterised by a robust fixed or folding frame, it enhances the concepts of “Minimum tillage” thanks to three ranks of tines. The high ground clearance and generous spacing among the tines guarantee a working depth of up to 25 cm, while the disc harrow and the rear roller mix and level the soil with the the residue.

TECHNICAL DATA CARD



Chassis	Fixed (TERREMOTO 3)				Folding (TERREMOTO 3 F)	
Model		300	350	400	400	500
Power	HP	110-180	130-200	150-250	160-250	205-300
Working width	m	3	3,5	4	4	5
Transport width	m	3	3,5	4,1	3	3
Working depth	cm	25	25	25	25	25
Number of tines	n°	10	12	13	13	17
Distance between ripper tines	cm	70	70	70	70	70
Weight*	kg	1388/1778	1626/2011	1753/2243	2605/3055	3160/3400

*Non stop/bolt version with roller cage Ø 450 mm

THE HANDYMAN FOR YOUR FARM!

TERREMOTO 3 has two types of chassis: 3, 3.5 and 4 metre fixed and 4 & 5 metre folding. The models available can be hooked up to 100 - 300 HP tractors and achieve maximum operating efficiency above 10 Km/h.

Objective optimisation

A SINGLE PASS FOR MULTIPLE BENEFITS

The sturdy chassis is divided into 2 work sections: the frontal section comprises 2 (TERREMOTO 2) or 3 (TERREMOTO 3) ranks of well-spaced tines that break the clods, remix the surface stratum and bury the residue. The rear section has one rank of discs, arranged behind the tines, that level the ground. Lastly, a re-compaction roller re-consolidates the ground to leave it ready for sowing.

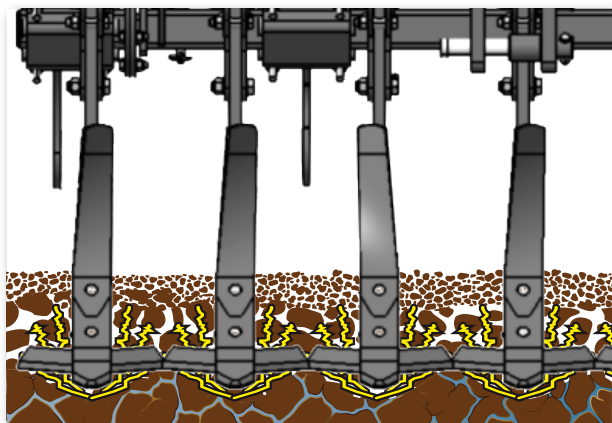

UNIFORM PREPARATION OVER THE ENTIRE SURFACE

The use of tines mounted wings makes it possible to work along the entire working width ensuring an excellent quality of work that results in a well-prepared seedbed.



Zona 1

TINES

The tines are arranged in staggered manner over 2 (TERREMOTO 2) or 3 (TERREMOTO 3) working ranks to ensure the best flow of soil even at high working speeds. Each tine is fitted with a side wing that remixes the soil as well as burying the surface residue.

Technology made easier

WORKING RESIDUES WITHOUT CLOGGING

The sturdy chassis has square hollow sections that ensure maximum reliability and strength. High ground clearance (90 cm) and the distribution of the tines over 3 well-spaced ranks (70 cm) ensure maximum speed of use without the risk of clogging.

TERREMOTO 2

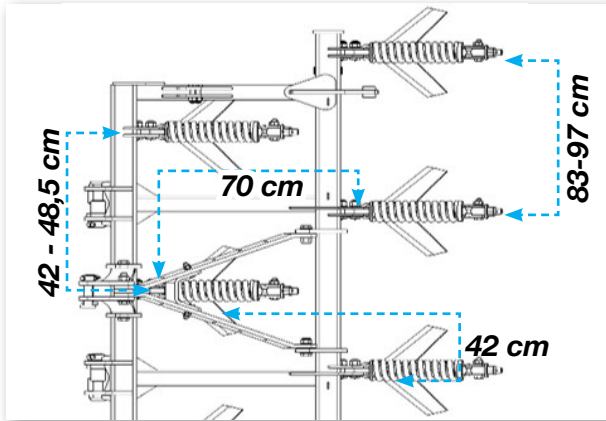

TERREMOTO 3

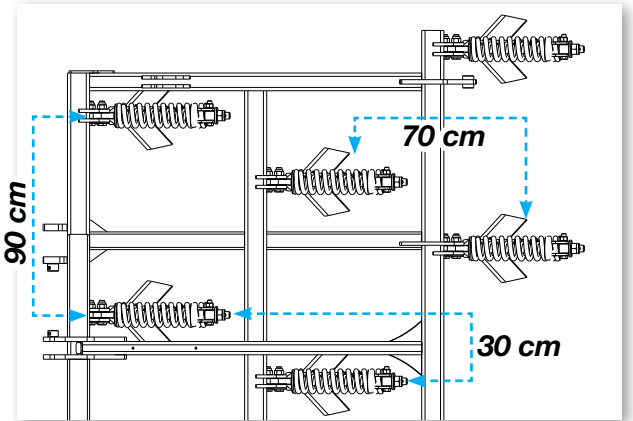

Zona 2

Zona 3

GROUND LEVELLING

After the tines have passed, a rank of \varnothing 520 mm discs levels off the ground, buries the residue and closes any furrows that may be left. The discs are mounted on Silent Blocks and are staggered to ensure optimal flow even with soil that is wet or rich in residue.

EFFECTIVENESS MADE EASY!

TERREMOTO stubble cultivators ensure maximum land preparation versatility. Their effectiveness is well-proven on autumn-spring land with high moisture as well as when there is considerable residue, for example when handling a second summer harvest.

TERREMOTO 3

Equipment and accessories



TERREMOTO 2 300

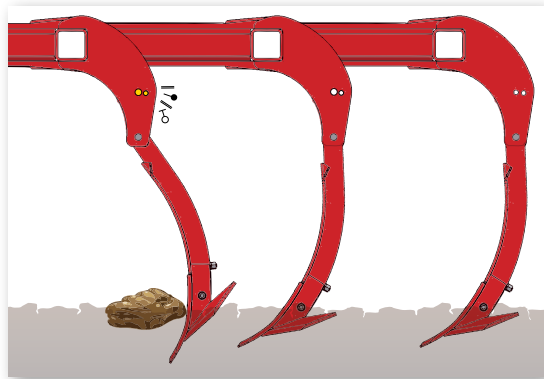

SAFETY BOLT

An effective and economic safety bolt indicated for ground with little shale protects the structure of the chassis. In the event of accidental blows against roots and rocks, the bolt snaps so that the ripper can be lifted. In this case, repair is very easy and accessible and only requires the replacement of the individual bolt.

NON STOP VERSION

For even more working comfort and more versatility on ground rich in shale, a NON STOP version is available with spring shock absorbers. During work stages, the tine is protected by the spring that intervenes at pressures over 450 kg: it lifts until the obstacle is overcome and then returns to the work position.

ANTI-STRESS SHOCK ABSORBER

The twin-spring structure cancels out vibrations in the work stage and ensures that the spring intervenes only after the calibration load is exceeded.



SIDE SHIELDS

Practical side shields are available on request. These simple elements play a very important role in containing the freshly worked soil and preventing it from shifting to the side. Handling is done manually to reduce the size of the equipment during transport. Adjustment is done manually by means of adjusting pins.



TERREMOTO 3 F 500



EFFICIENCY AND LONG LIFE

To ensure a long operating life even when working on difficult soils, hardened steel and tungsten-coated tips are available for increased abrasion resistance. The deflector with curved profile facilitates stirring, while the side wings ensure the soil movement on the surface.

Long-life tip

To ensure a long operating life-span even when working difficult land, hardened steel tips are available with tungsten coatings for even better resistance to abrasion.

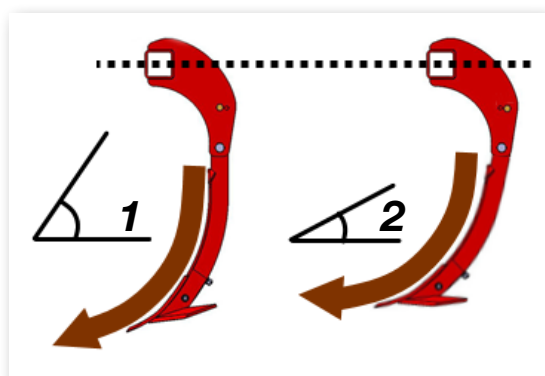
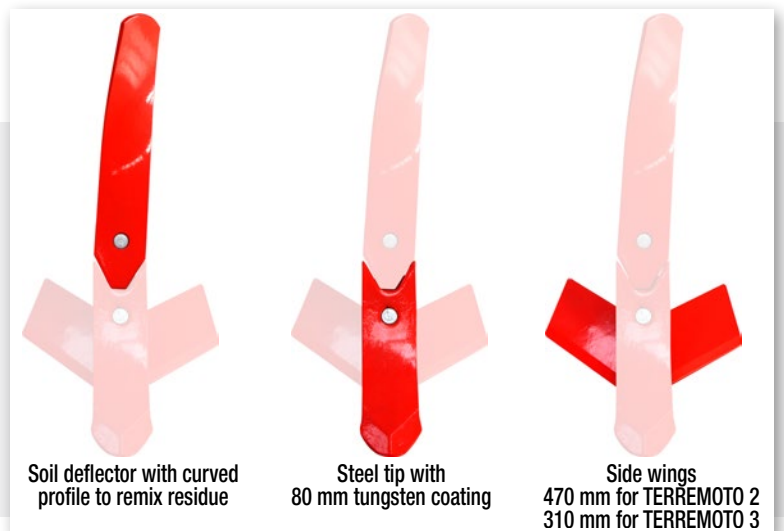

DUAL WORK POSITION

In relation to the hardness of the ground and tractor power, rippers can be arranged in 2 work positions: in the first position (1) the ripper has a more aggressive tip approach angle to work more soil; in the second position (2) the approach angle is more closed for lower power absorption .

A TERREMOTO for every season!



TERREMOTO 3 F 500



FAST PREPARATION OF THE SEED BED

In summer.
TERREMOTO can be used for preparation on hard ground for a second harvest. The large clearance between elements ensuring better flow of residue is one of the strong points of this equipment.

ROUGHING WINTER SOIL

In winter-spring.
Roughing can be carried out as part of conventional soil working or minimum tillage depending on crop requirements.



BURIAL OF CROP RESIDUES

In autumn.
TERREMOTO is ideal for direct work on unworked land or after deeper processing (ploughing-clod breaking). Its design has proven to be effective on wet land (U and V ringrollers).

DEPENDING ON REQUIREMENTS

In relation to the crop to be sown and the type of seed drill available, it is possible to opt for minimal preparation (1st pass) or a more refined seed bed (2nd pass).

Not worked

1° ride

2° ride

It's a matter of rollers



Ø 600 mm

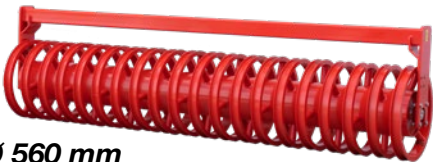

Ø 560 mm

RING ROLLER AND U ROLLER

These roller models offer maximum in-use versatility, especially on wet land that has to be levelled and consolidated without excessive compaction. Compact bands alternating with unworked bands are created on the ground that encourage the exchange of air and water while avoiding the formation of surface crusts or stagnant water.

CAGE ROLLER

Ideal for dry ground, providing good refining and surface levelling. The Ø 550 mm diameter is ideal for reducing excessive clods. The limited weight reduces the rear overhang for better hook-up with lightweight tractors.



Ø 450 - 550 mm



Ø 600 mm

RING PACKER ROLLER

This roller allows for a great versatility in use. In this case, the vertical impact of the roller allows refinement of the surface soil while leaving more clods in the underlying strata for better root development. This kind of seed bed presents alternating worked and unworked bands for more versatility in wet soils.

DRACULA HYDRO

Combined cultivator



DRACULA HYDRO 430

EVERYTHING IN A SINGLE PASS

Sturdiness and productivity are the main features of DRACULA HYDRO, the top of the range combined cultivator for soil tillage. Thanks to the combination of discs and tines, this cultivator handles - in a single pass - crop residues, soil aeration, levelling and preparation of the seed bed. DRACULA HYDRO embodies efficiency, timeliness and working quality in a single machinery.

TECHNICAL DATA CARD



Model		FISSO		PIEGHEVOLE	
Chassis		300	400	430	630
Power	HP	200-300	300-400	280-400	330-550
Working width	m	3	4	4,3	6,3
Transport width	m	3	4	3	3
Working depth	cm	30	30	30	30
Number of tines	n°	7	9	9	13
Discs N°/ø	mm	12/610	16/610	18/610	26/610
Weight	kg	5200	6300	8050	10600
Hydraulic connectors	n° pairs	3	3	4	4

MAXIMUM VERSATILITY

DRACULA HYDRO is a combined cultivator comprising 3 work sections capable burying residue, de-compacting deeper strata and re-compacting the soil. The possibility of adjusting each section independently means that DRACULA HYDRO adapts to the needs of every site for 360° flexibility in use.



DRACULA HYDRO 300



CONSTRUCTION MODULARITY
 DRACULA HYDRO in the fixed version (300 and 400) uses a central beam frame coupled with a spar structure and cross members that allows modular assembly. The application plates located on the side crossbeams allow the machine to be assembled in the 3-metre and 4-metre configuration by means of special extensions. The central frame structure has a footprint of only 2.55 cm, making it ideal for transport in gauge.

EFFICIENCY AND LONG LIFE
 To ensure a long operating life-span even when working difficult land, hardened steel tips are available with tungsten coatings for even better resistance to abrasion. The curved profile deflector facilitates stirring, while the side wings ensure the movement of the soil on the surface.

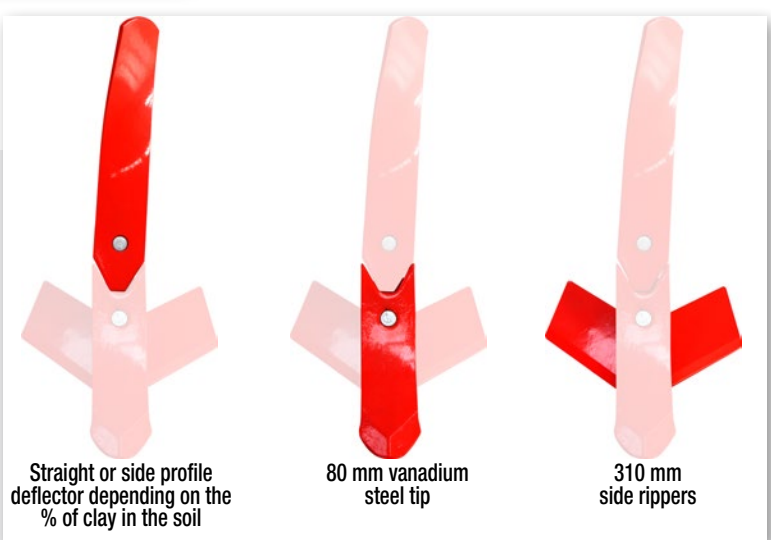

Straight or side profile deflector depending on the % of clay in the soil

80 mm vanadium steel tip

310 mm side rippers

Maximizing results

HEAVY DUTY FRAME

The various work sections are held together by a solid, sturdy central chassis. Tested in the most demanding work conditions, it can be hooked up to tractors offering powers of up to 600 HP and is capable of operating at high work speeds (around 8-10 km/h).



PERFECT TOWING WITH EVERY KIND OF TRACTOR

The threaded drawbar means that the height of the eyebolt can be adjusted in relation to the fitting on the tractor (from 40 to 90 cm) to ensure a correct setting of the work level.



Zone 1

CUTTING AND MIXING

The two ranks of front discs cut the residue, pull the roots and remix organic substance in the soil for faster decomposition. The 610 mm discs allow work depths up to 15 cm.

La tecnologia si fa semplice

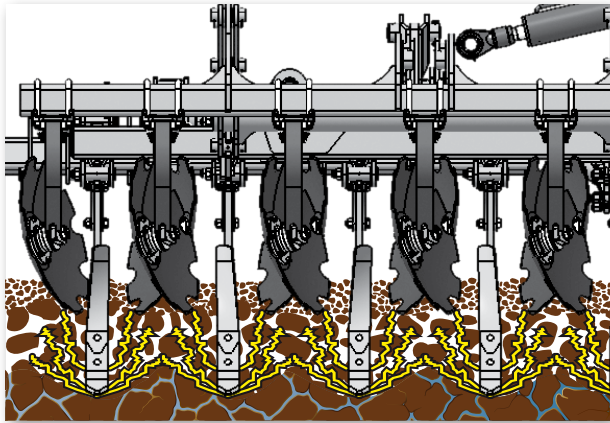

COMBINED SYSTEM FOR ASSURED IMPACT

The perfect overlapping of large-diameter discs and rippers ensures uniform processing over the entire working width. To achieve maximum work effectiveness, discs and tines are arranged at equal distances to provide incomparable work uniformity.

HYDROPNEUMATIC SAFETY SYSTEM

DRACULA HYDRO uses a new hydropneumatic safety system. The equipment's hydraulic system is preloaded directly with the tractor's hydraulic system up to a standard value of 120 bar. Thanks to the nitrogen tanks, the gas is compressed if the tines encounter obstacles that generate pressures over 900 kg. The HYDRO system cancels out vibrations and ensures linear compression, able to limit jerks and return the tine to the correct working depth until the obstacle is overcome. As a basic feature, the equipment is always equipped with a shear bolt safety system.



Zone 2

CLOD BREAKING

The tines are distributed over 2 or 3 ranks (respectively for 430 and 630 versions) to allow more flow of soil and avoid clogging when working residue. The shape of the tine is designed to ensure more penetration into the soil for a work depth up to 30 cm.

Zone 3

LEVELLING AND RE-CONSOLIDATION

The rear section levels off and re-consolidates the land: a rank of \varnothing 520 mm discs with a Silent Block shock absorber system closes the furrows left by the tines, while the roller (600 mm in diameter) re-consolidates the soil for subsequent sowing.

DRACULA HYDRO

Technology and quality



DRACULA HYDRO 300

AGGRESSIVE CHARACTER

Thanks to its discs (610 mm in diameter) mounted on independent, high-travel “C” springs, DRACULA HYDRO offers impressive ground cutting and burying performance even on the toughest sites while also handling large quantities of residue. The very aggressive disc profile amplifies the cutting effect on the residue, while always ensuring impressive incisiveness on the ground.



OBJECTIVE: CUTTING MAINTENANCE TIMES

To ensure high working autonomy, the two rows of discs have a special high-performance “CULTI-HUB”. The dual oil bath bearing is effectively protected by a sealing system against water, mud and dust. Oil bath lubrication ensures long operating life and does not require greasing at regular intervals.

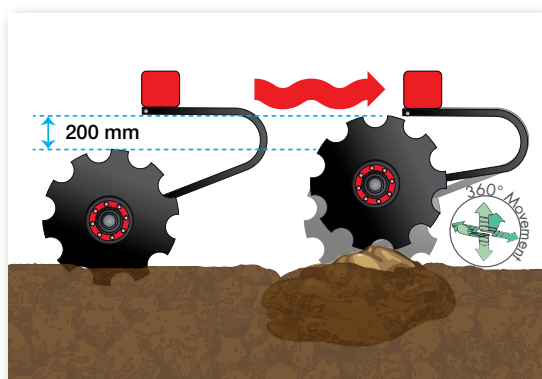
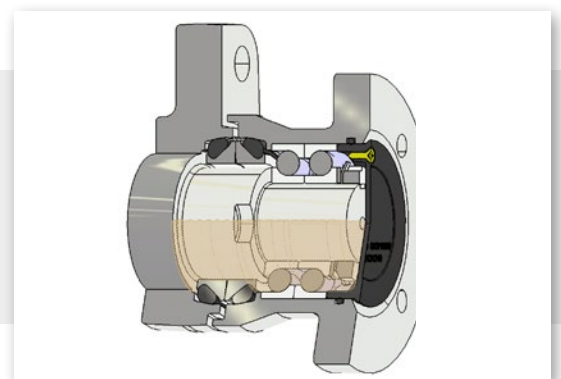

“C-SHAPED” SPRING FOR EVEN MORE VERSATILITY

To ensure maximum in-use versatility of the disc set, a special “C-shaped” spring has been developed that ensures high flexibility (travel of 200 mm) and a long operating life. The simple, straightforward shape prevents any clogging with soil and residue.

The right solution in every situation



WET GROUND IN WINTER

In winter-spring, DRACULA HYDRO can be used to bury crop residue and prepare the soil for sowing in spring. Working depth up to 30 cm.

DRY LAND RICH IN RESIDUE

In summer. Preparation tillage for a second harvest. Independent management of sections for working the surface at 15-20 cm.



TENACIOUS LAND RICH IN RESIDUE

In autumn. DRACULA HYDRO cultivator can act directly on unworked land even when there is plentiful residue. The front disc set offers excellent clearance for maximum flow of residue and soil.



Everything in a single pass!

A universal roller for every work condition

DRACULA HYDRO 430

IDEAL FLATTENING AND LEVELLING

To ensure that rear section is always set in the best possible way, it is important to adjust the depth of the rear roller (1) as well as the height of the levelling discs (2). In this way, it is possible to achieve the correct work depth as well as level off the soil by closing the furrows created by the tines.



RING PACKER ROLLER: MAXIMUM RESULTS IN EVERY CONDITION

DRACULA HYDRO is equipped with a Packer Ring Roller (ø 600 mm) specifically for soil re-consolidation. In this case, the vertical impact of the roller allows refinement of the surface soil while leaving more clods in the underlying strata for better root development. This kind of seed bed presents alternating worked and unworked bands for more versatility in wet soils.

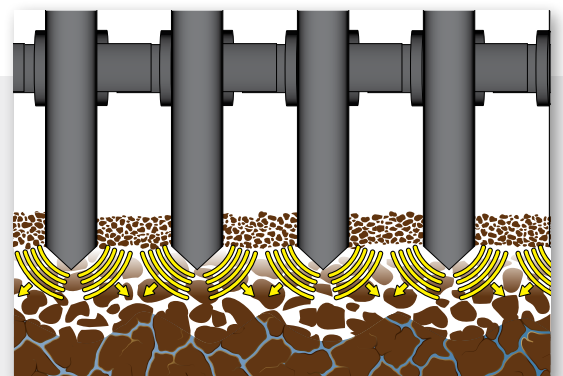



SAFE ROAD TRANSPORT

DRACULA HYDRO, with fixed or folding frame, can be MOTHER REGULATION approved with pneumatic braking system at 40 km/h or hydraulic dual-line braking system at 30 km/h. When the machine is disconnected, a parking brake immediately locks the wheels. Two sturdy feet support the equipment when parked.



SMALL FOOTPRINT EVEN DURING TRANSPORT

DRACULA HYDRO, with fixed (in the 3-metre configuration) or folding frame, has a road footprint of only 3 metres. The folding versions are equipped with locking brackets to prevent any accidental opening of the wings during transport.

