



RAI AMSTERDAM

13 – 16 SEPTEMBER 2024

Meeting Suite Package 1



*Graphics are not included in the package, graphics and additional furniture can be ordered via exhibitorservices@rai.nl

Meeting Suite Package 1 (based on 16m²)

- Standard white shell scheme walls 100x250 cm (wxh)
 - Ceiling plinth of 10cm for stability and lights
 - Company name and meeting suite number
 - 1x lockable door
 - 1x window panel 100x250cm (wxh)
 - 1m x 1m colour company logo – mounted on white foamex board and placed on the front wall
 - Dark grey carpet – colour can be changed
 - 1x 3kw (13A) daytime power supply including one double wall socket
 - 4 x LED spotlights
 - 1 x lockable cabinet
 - 2 x white tables
 - 8 x white chairs
 - 1 x waste bin
 - Basic stand cleaning
- 1x technical drawing and visual included. Design updates will be subject to an additional fee of €90 per hour.



All upgrade items can be booked via the [RAI Exhibitor Services Webshop](#).
For questions, please contact the RAI Exhibitor Services department.

☎ 0031 20 549 1928
exhibitorservices@rai.nl



Meeting Suites Package 2



*Graphics are not included in the package, graphics and furniture can be ordered via exhibitorservices@rai.nl

Meeting Suite Package 2 (available from 40m²)

- High quality white walls 100x250cm (wxh)
 - Company name and meeting suite number
 - 1 x lockable door
 - Dark grey carpet – colour can be changed
 - 2 x 3kW (13A) daytime power supply including one double wall socket
 - LED spotlights - one spotlight for every 4m²
 - Basic stand cleaning
- 1x technical drawing and visual included. Design updates will be subject to an additional fee of €90 per hour.

Please note that furniture is not included and can be ordered via the [RAI Exhibitor Services Webshop](#).



All upgrade items can be booked via the [RAI Exhibitor Services Webshop](#).
For questions, please contact the RAI Exhibitor Services department.

☎ 0031 20 549 1928
exhibitorservices@rai.nl

Meeting Suite upgrade options



*Meeting Suite impressions

Upgrade options (available via the RAI Exhibitor Services Webshop):

- Power, internet & water
- Mini market
- Catering service
- Furniture
- Plants & flowers
- Electrical appliances
- Temporary staff



All upgrade items can be booked via the [RAI Exhibitor Services Webshop](#).
For questions, please contact the RAI Exhibitor Services department.

☎ 0031 20 549 1928
exhibitorservices@rai.nl

Meeting Suite Package 1 - Specifications

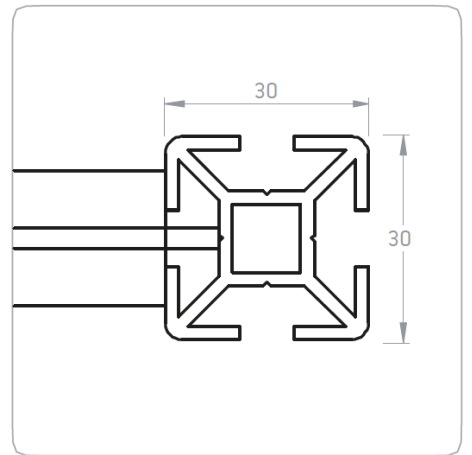
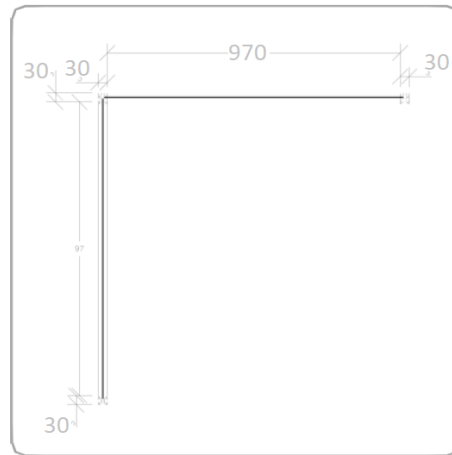
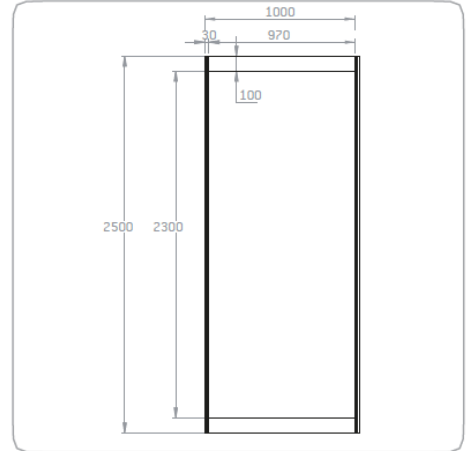
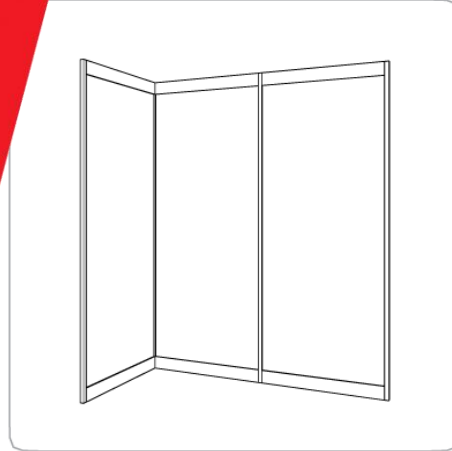

Meeting Suite Package 1 – Specifications

- White system wall element 970x2500x6mm
- Center to center dimensions 1000mm
- Aluminium pole 30x30x2500mm



All upgrade items can be booked via the [RAI Exhibitor Services Webshop](#).
For questions, please contact the RAI Exhibitor Services department.

☎ 0031 20 549 1928
exhibitorservices@rai.nl

Meeting Suite Package 2 - Specifications

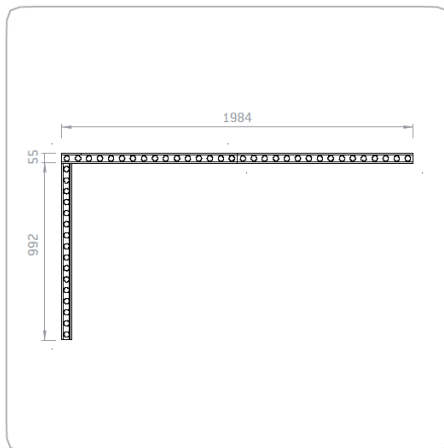
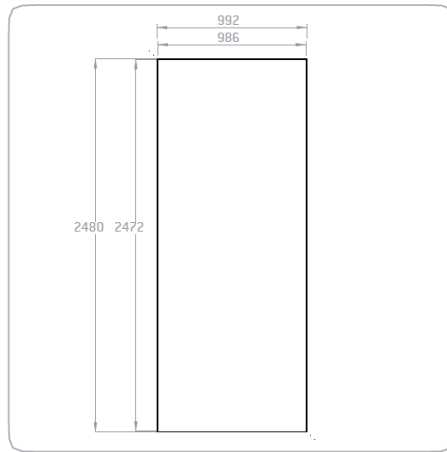
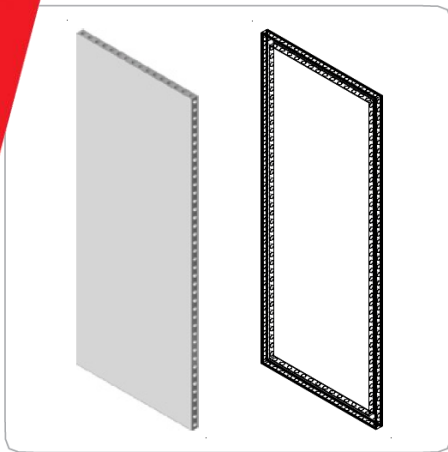

Meeting Suite Package 2 – Specifications

- White system wall element 992x2480x55mm
- Panel size 986x2472mm



All upgrade items can be booked via the [RAI Exhibitor Services Webshop](#).
For questions, please contact the RAI Exhibitor Services department.

☎ 0031 20 549 1928
exhibitorservices@rai.nl



Electricity

Power consumption list (for reference only)

Halogen lights 12v	50W
Fluorescent lights (max p. unit)	100W
Refrigerator (small)	500W
Refrigerator (large)	1000W
Freezer	2000W
Coffee machine (small)	1000W
Coffee machine (large)	3000W
Microwave	1200W
Kitchen rental unit	2x 3000W
Computer	400W
Laptop	500W
Plasma screen	650W
LCD television	200W
Video projector (large)	2500W
Copier machine	3000W
Dishwasher	3000W
Boiler	3000W
Kettle	1000W

*1000W = 1 kW



All upgrade items can be booked via the [RAI Exhibitor Services Webshop](#).
For questions, please contact the RAI Exhibitor Services department.

☎ 0031 20 549 1928
exhibitorservices@rai.nl