



RAI AMSTERDAM
11-14 SEPTEMBER 2026

Future Tech Pod



IBC2026

FUTURE TECH POD



All upgrade items can be booked via the [RAI Exhibitor Services Webshop](#).
For questions, please contact the RAI Exhibitor Services department.

☎ 0031 20 549 1928
exhibitorservices@rai.nl

rai
AMSTERDAM



RAI AMSTERDAM

11-14 SEPTEMBER 2026

Future Tech Pod

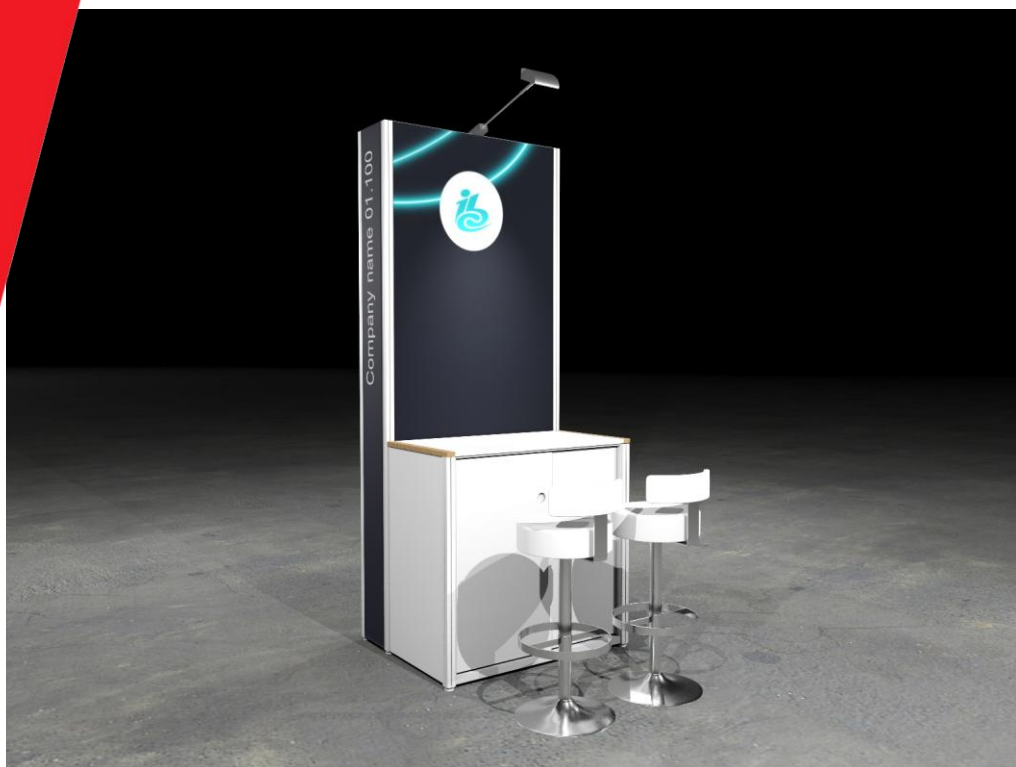

Future Tech Pod

- Premium quality pod (2.5m high)
- Graphics on the pod front panel included - **visible print area 950mm x 1500mm (WxH)**
- Integrated lockable counter
- Option to upgrade and add graphics to the counter
- 2 x high stools
- 1 x 3kW (13A) daytime power supply including one double wall socket
- 1 x LED spotlight
- Company name and pod number
- Exhibitor Wi-Fi (for personal devices)



All upgrade items can be booked via the [RAI Exhibitor Services Webshop](#).
For questions, please contact the RAI Exhibitor Services department.

☎ 0031 20 549 1928
exhibitorservices@rai.nl

rai
AMSTERDAM



RAI AMSTERDAM

11-14 SEPTEMBER 2026

Future Tech Pod Upgrade Options

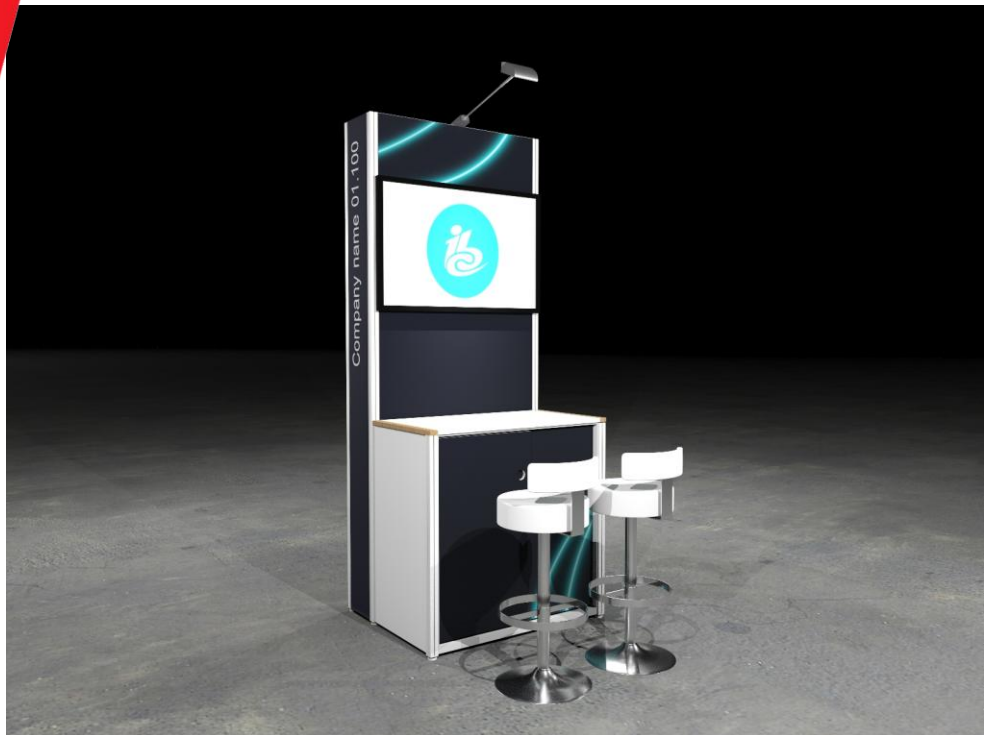

Future Tech Pod - Upgrade Options

- Power
- Internet
- Graphics
- Lighting
- Mini market
- Catering service
- Furniture
- Plants & flowers
- Electrical appliances
- Temporary staff
- Audio/Visual equipment
- Wall reinforcement (required for affixed TV screens) - cost from €192.80 excl. VAT



All upgrade items can be booked via the [RAI Exhibitor Services Webshop](#).
For questions, please contact the RAI Exhibitor Services department.

☎ 0031 20 549 1928
exhibitorservices@rai.nl



RAI AMSTERDAM

11-14 SEPTEMBER 2026

Future Tech Pod Technical Drawing

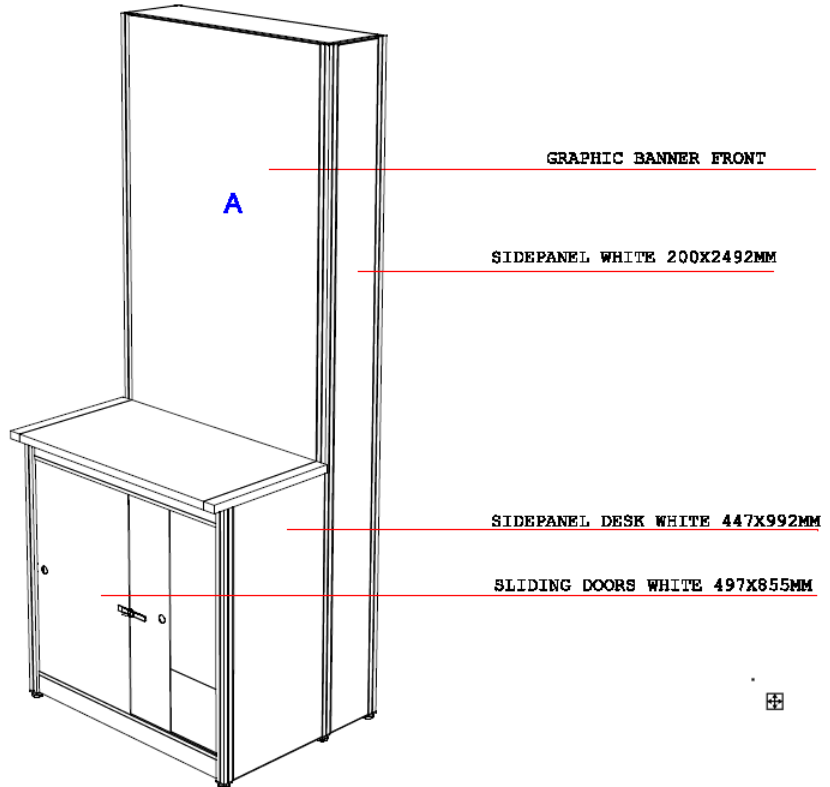

Print Size (WxH)

A: 950 x 2500mm - **visible print area 950mm x 1500mm**



All upgrade items can be booked via the [RAI Exhibitor Services Webshop](#).
For questions, please contact the RAI Exhibitor Services department.

☎ 0031 20 549 1928
exhibitorservices@rai.nl

rai
AMSTERDAM



RAI AMSTERDAM

11-14 SEPTEMBER 2026

Electricity

Power consumption list (for reference only)

Halogen lights 12v	50W
Fluorescent lights (max p. unit)	100W
Refrigerator (small)	500W
Refrigerator (large)	1000W
Freezer	2000W
Coffee machine (small)	1000W
Coffee machine (large)	3000W
Microwave	1200W
Kitchen rental unit	2x 3000W
Computer	400W
Laptop	500W
Plasma screen	650W
LCD television	200W
Video projector (large)	2500W
Copier machine	3000W
Dishwasher	3000W
Boiler	3000W
Kettle	1000W

*1000W = 1 kW



All upgrade items can be booked via the [RAI Exhibitor Services Webshop](#).
For questions, please contact the RAI Exhibitor Services department.

☎ 0031 20 549 1928
exhibitorservices@rai.nl



RAI AMSTERDAM

11-14 SEPTEMBER 2026



IBC2026

Rate Card

Power

[Daytime power 3 kW \(incl. double wall socket\)](#)

[Daytime power 10 kW \(incl. CEE 16A\)](#)

[Continuous power 3 kW \(incl. double wall socket\)](#)

[Continuous power 10 kW \(incl. CEE 16A\)](#)

[Additional wall socket \(excl. daytime power\)](#)

[Power during build-up and breakdown](#)

Internet

[2 Mbps internet connection](#)

[10 Mbps internet connection](#)

AV

[43" Touchscreen](#)

[55" LED 4K screen](#)

Cleaning

[Upgrade to all-inclusive stand cleaning](#)

[Residual waste container \(1m³\)](#)



All upgrade items can be booked via the [RAI Exhibitor Services Webshop](#).
For questions, please contact the RAI Exhibitor Services department.

☎ 0031 20 549 1928
exhibitorservices@rai.nl