

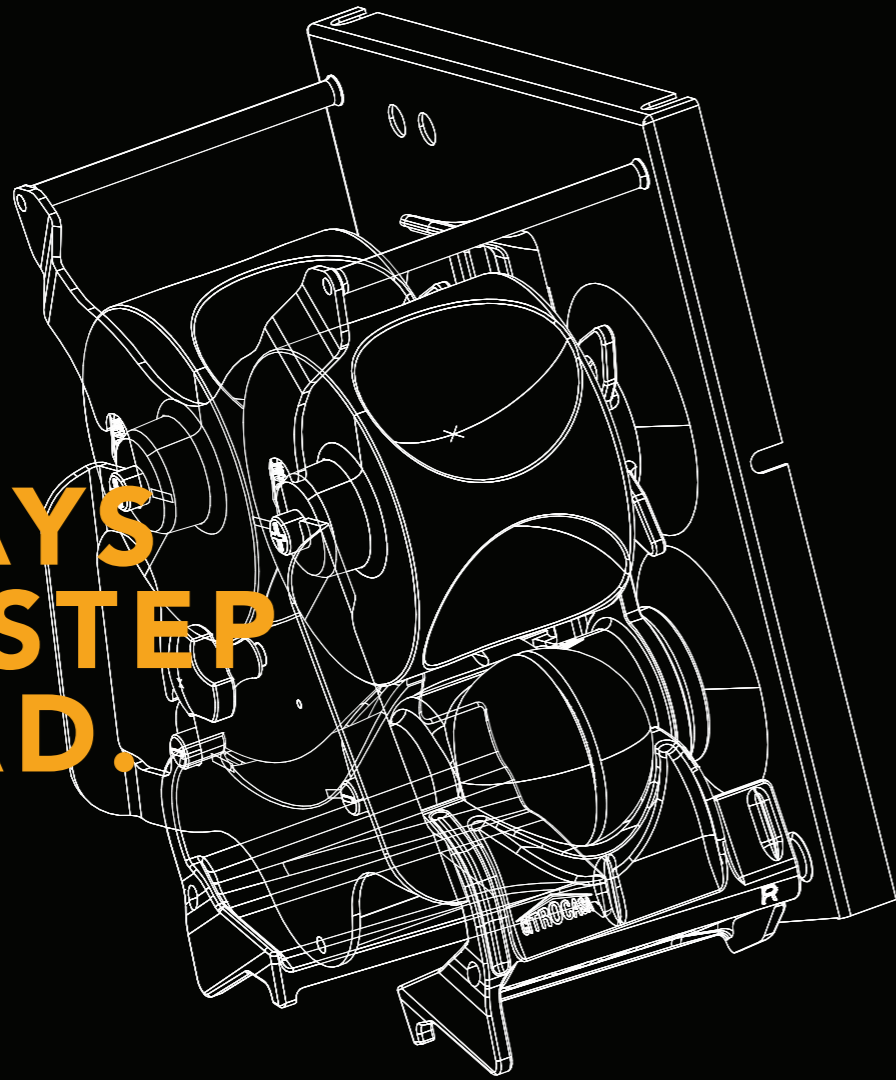

iSqueeze
let's get juicing!

The logo features the word "iSqueeze" in a white, sans-serif font. The letter "u" is stylized to resemble a citrus fruit with a stem and two leaves. Below the main text is the tagline "let's get juicing!" in a smaller, lowercase, sans-serif font. The entire logo is centered on a black background, which is framed by thin, gold-colored lines forming a large, stylized arrow shape pointing towards the center.

ALWAYS ONE STEP AHEAD.



As a leading global partner of retail grocers and restaurateurs, we are always moving forward. We are uncompromising in the development of our long-lasting premium juicers. We never stop improving – each new design should be a bit better, more efficient, more sustainable. That's our daily challenge to ourselves. And it has made us who we are today: the technological leader in freshness and innovation.

SIMPLY UNBEATABLE



HYGIENIC

Maximum hygiene through double cover technology.



PREMIUM

Top quality juice thanks to precision cutting.



PROFITABLE

Optimal fruit juice yield and processing.



EFFICIENT

Our innovative design enables fast & easy cleaning.



100% SAFE

Highest safety standards during both use and maintenance.



CONVENIENT

Machines, fruit and bottles – all from one supplier.



CONVENIENCE

Everyday work is demanding enough – our answer is simplicity. The Double cover of the machine is the key component for our 2-zone technology and makes disassembling and cleaning a Citrocas juicer fast and easy.



SUSTAINABILITY

To ensure maximum hygiene and lifetime, all relevant zones of a Citrocas juicer are made of high-quality stainless steel. For our customers that means the best quality juice, impeccable hygiene and excellent value retention.



SAFETY

In our patented Crossholder, all end components are fixed with a screw fastening. The squeezing and cutting tools can be removed for cleaning or replaced in seconds. A magnetic switch guarantees that the juicer only runs when everything is 100% secure.

FLAVOUR

Cutting rather than tearing: precise and dynamic fruit cutting prevents bitter substances and essential oils contained in the orange peel from contaminating the juice – and guarantees top-quality juice.

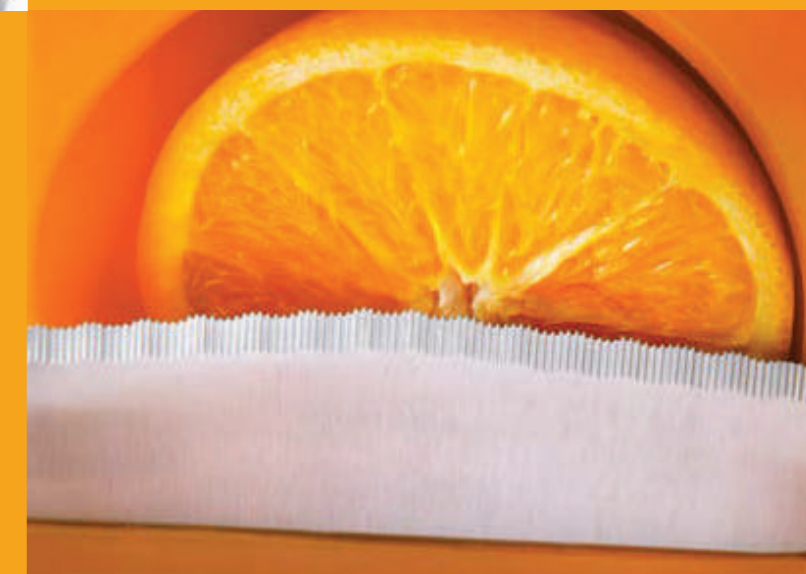



PERFORMING FRESHNESS

FROM DEVELOPMENT TO THE FINISHED PRODUCT

PRODUCT DEVELOPMENT

New ideas take shape when people interact with our products, whether at our in-house product development division or in the market. We constantly keep our ears open for comments from our customers and partners and react quickly to the demands of global markets. iSqueeze stands for short development cycles and fresh ideas that move us and our customers forward every day.

PRODUCTION

The best freshly squeezed juice requires state-of-the-art machine production facilities. All of our premium juicers are tested exhaustively to fulfill iSqueeze's exacting quality standards. Only those which survive this battery of tests leave our factory. The results are plain to see (and taste): Performing freshness in each bottle and each glass.

A PROMISE OF QUALITY

Not only what we do is important, but also how we do it. For this reason, our promise of quality continues long after our premium juicer has been installed on location. We offer our customers technical support and service wherever it is needed. All it takes is a phone call, and we set everything in motion.

VARIETY MEETS EFFICIENCY

PERFORMING FRESHNESS IN THE SELECTION OF INGREDIENTS FOR FRESHLY SQUEEZED JUICES

There's no need to stop at orange juice. In addition to the classic option, our juicers are made to be compatible with a wide variety of other juices. Variety and efficiency – both also part of performing freshness.



POMEGRANATE

A symbol of life and fertility. Contains a wealth of organic substances that actively support our immune system.



ORANGE

The classic freshly squeezed juice. The orange is the most common citrus fruit in the world.



GRAPEFRUIT

A hybrid between orange and pomelo, this once "forbidden fruit" is growing in popularity.

LIME

Lemon's little sister stands out with a stronger aroma.



LEMON

The foundation of any good lemonade – the juicy, tart flesh contains between 3.5–8 citric acid and plenty of vitamin C.





PERFORMING FRESHNESS OFFERING THE VERY BEST EVERY DAY

A glass of freshly squeezed juice is a treat for all of the senses. In addition to the refreshing taste, unique smell and high quality of fruit, it includes several essential nutrients and bioactive substances not found in prepackaged products high in fruit concentrate. Looking out for one's guests and customers means offering the best: Performing freshness from iSqueeze.

THE PERFECT SOLUTION FOR ANY LOCATION



BAR & CAFÉ

The ideal solution for locations with limited space and high design standards. Your guests will appreciate the freshness on offer.

REVOLUTION / FANTASTIC



HOTEL & RESTAURANT

Any location with space for equipment behind the bar or at a breakfast buffet is transformed by one of these juicers, giving your guests a fresh start to their day.

ECO / FANTASTIC / 8000



BAKERIES

Fresh bread and freshly squeezed juice - a combination that makes any day a good day, for you and your customers. And when it comes to turnover you might look forward to using more dough in the future.

ECO / REVOLUTION / FANTASTIC



SUPERMARKET

Anywhere heavy customer traffic requires almost industrial production speed, our juicers are the best choice. After all, additional revenue doesn't grow on trees, even if it seems to with iSqueeze.

FANTASTIC / 8000



FILLING STATIONS

Not only cars need a refill from time to time. Your customers have earned a bit of real refreshment for their travels. Our juicers are veritable vitamin filling stations that really pump

FANTASTIC / 8000



CONVENIENCE

Wherever refreshments should come into play, our juicers are in their element. "Freshness to go" has never been this simple.

FANTASTIC / 8000



OUR COMPLETE SYSTEM

MACHINES - FRUITS - BOTTLES

MANUAL ECO LINE



STARLIGHT

The basic machine offers an easy first step into the world of iSqueeze.

**PERFORMING FRESHNESS
TAKE CONTROL OF THE FUTURE.**

Everything tastes best made fresh. iSqueeze brings this experience back into our daily life, putting real freshness and flavour at your fingertips. The 18 kg oscillating weights heighten the effectiveness of the juicing elements, enabling smooth and fluid motion in the machine even when running without electricity. Ideal for hotels, organic markets, cafés, beach bars or rustic cabins.



FANTASTIC ECO

Experience freshness at your fingertips. This juicer combines the design and quality hallmarks of the Fantastic series with an elegant manual drive.



FANTASTIC ECO PLUS

This machine combines high juice output with minimal effort. With its bountiful fruit basket and elegant manual drive, the Eco Plus offers the ultimate freshness experience.



STARLIGHT 79.5 x 51.5 x 51 cm / 46 kg	FANTASTIC ECO 78 x 57.5 x 56 cm / 56 kg	FANTASTIC ECO PLUS 94.5 x 57.5 x 56.5 cm / 67 kg
---	---	--

COMPACT REVOLUTION



REVOLUTION

Our smallest juicer stands out thanks to its design, compact 24 cm-wide footprint and the compelling performance one can expect from iSqueeze technology.



A small footprint can still offer variety. The Revolution juices both oranges and pomegranates – it really is that simple.



PERFORMING FRESHNESS IN A SMALL PACKAGE

Revolutionizing the enjoyment of freshness without taking over the floor plan. A small machine that offers high performance, quick cleaning and 100% iSqueeze quality are only a few of the revolutionary advantages never seen before from such a small, compact juicer. The Compact line will be a valuable asset to your location and is the perfect solution for smaller spaces with high standards of design and quality.

REVOLUTION
77 x 24 x 51.2 cm / 40 kg

15x 🍊 = 1l/min 🍹

MEDIUM CAPACITY



FANTASTIC M/AS

Ease of use make this machine shine. Glass in place, oranges in the top and the machine starts automatically.



FANTASTIC M/SB

Performance meets ease of use – the finest freshly squeezed juice activated via the tap.



PERFORMING FRESHNESS GOURMET QUALITY WITH NO FUSS

With our Fantastic line, you are sure to satisfy discerning customer tastes. The inspired design, user-friendliness and easy cleaning of all components make these juicers ideal for long-term use. Make a statement with exceptional freshness and quality.

FANTASTIC M
78 x 38 x 55.5 cm / 44 kg

30x 🍊 = 2l/min 🍹

A photograph of two young women in a grocery store. The woman on the left has blonde hair and is wearing a blue and red plaid shirt, holding a bottle of orange juice and smiling. The woman on the right has red hair and is wearing a light blue button-down shirt, laughing. In the background, there are shelves of groceries and a fruit display with oranges and apples. A yellow box is overlaid on the bottom left of the image.

**EVERY DAY THAT WE CAN ENJOY A
MOMENT OF FRESHNESS IS A GOOD DAY.**

We have had to let go of some conventions in order to offer the best freshly squeezed juice. Striving for perfection in every detail is our key to getting the best results. It is no simple task, but we are committed to it – and to our millions of satisfied customers every day.

**ENJOY
FRESHNESS**

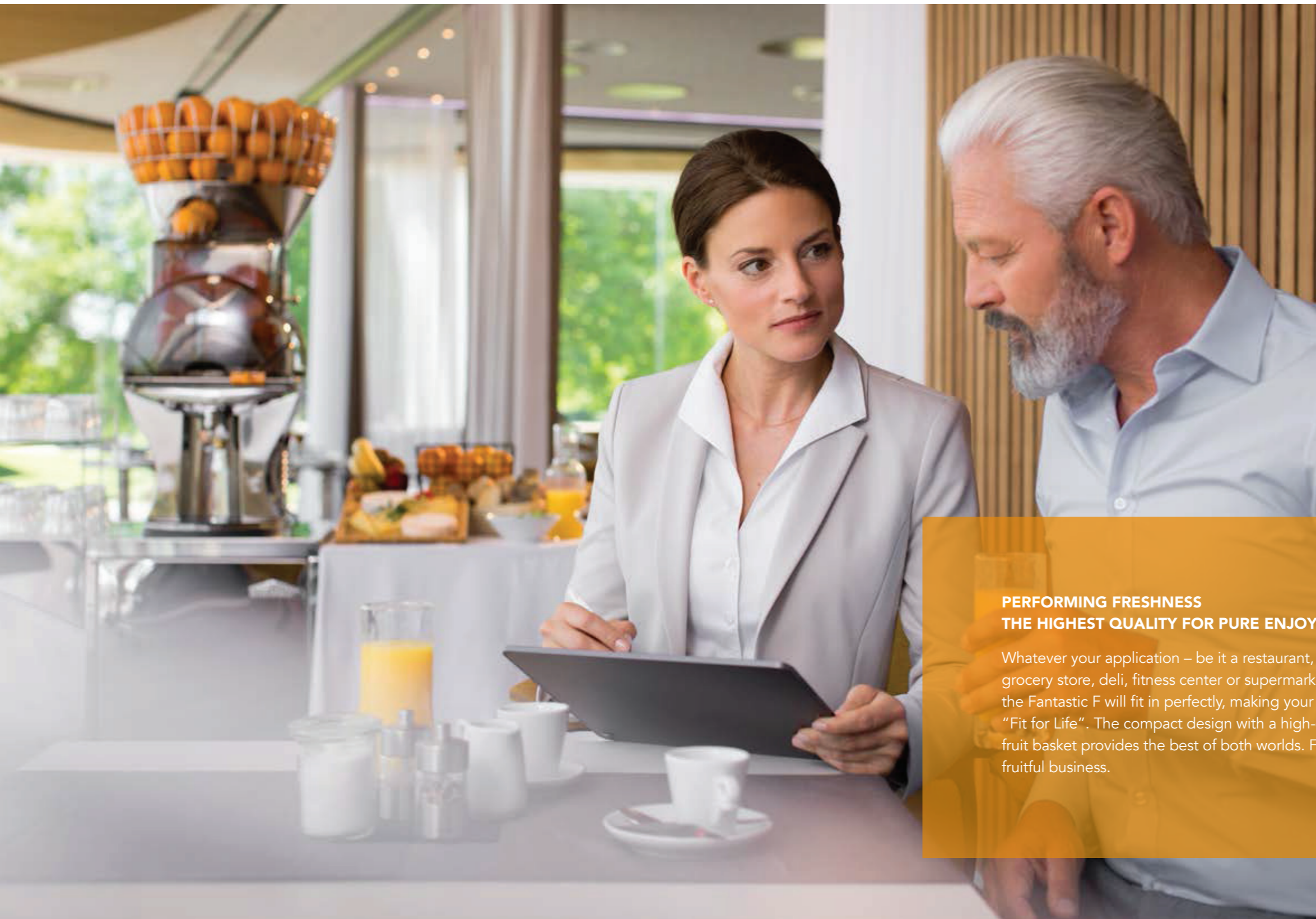

**PERFORMING FRESHNESS
THE HIGHEST QUALITY FOR PURE ENJOYMENT**

Whatever your application – be it a restaurant, organic grocery store, deli, fitness center or supermarket – the Fantastic F will fit in perfectly, making your location “Fit for Life”. The compact design with a high-capacity fruit basket provides the best of both worlds. For a fruitful business.



FANTASTIC F/D



Cutting-edge technology meets pure efficiency – the fully automated juicer with programmable fruit feeding is ideal for moderate to high-volume juice production at the touch of a button.



FANTASTIC F/SB

The finest self-service machine, proven internationally in retail. This machine is activated via the tap and has a capacity of 17 kg of oranges in its fruit basket (= approx. 5.6 l juice).

FANTASTIC F
94 x 50 x 65.5 cm / 52 kg

30 x  = 2l/min 

HIGH CAPACITY 2.0



FANTASTIC eXpress

The Fantastic eXpress is our brand-new premium orange juicer with the innovative OneStep juicing kit: with a single step, this machine is ready to be loaded in the dishwasher.



FANTASTIC CONNECT

Open for all of the important connections in day-to-day business. The Fantastic Connect is internet-ready, features several interfaces for cashier and payment systems and has a 7" touch screen. That way, nothing stands in the way of good business; on the contrary, it runs better than ever thanks to optimized data flow.



PERFORMING FRESHNESS
WE DRIVE INNOVATION BY
THINKING AHEAD

We have made it our mission to take our customers' affairs seriously and maintain the closest possible contact with the markets. As a result, we have been able to react quickly, pushing the limits of quality, simplicity and efficiency time and again. The result: two new machines that raise the standards to a new level thanks to new displays, automatic sieve cleansing, the OneStep juicing kit and individual connection possibilities.

30 x 🍊 = 2l/min 🍹

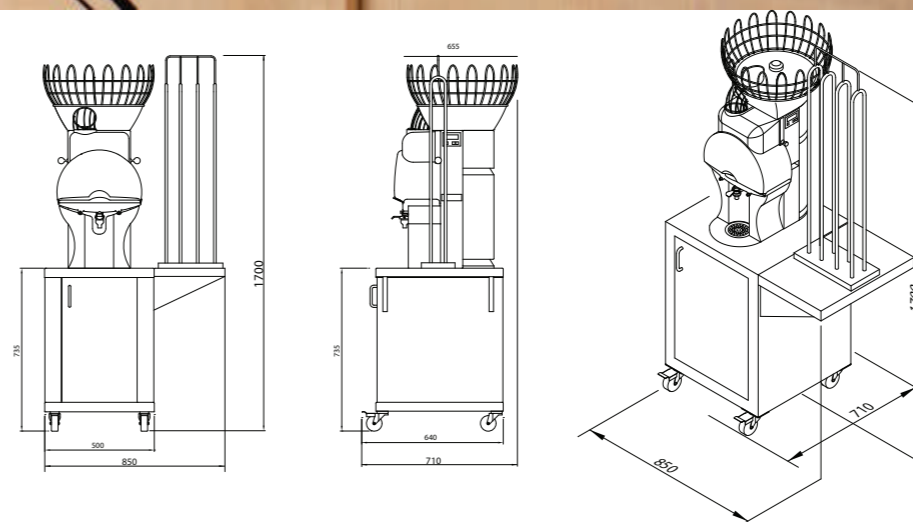

HEAVY DUTY CAPACITY



8000 XB

The perfect solution for juicing large quantities of orange juice in advance: the juice comes directly into a 5 l tank. The ideal system for applications where employees serve juice to customers in bottles or glasses.



8000 SB ATS

The 8000 SB ATS with automated sieve cleansing sets a completely new standard in self-service, user-friendliness and automation.



8000 SB ATS POME

The ideal machine for freshly squeezed pomegranate juice. Its automated sieve cleansing feature ensures a fresh change in the self-service area.



40 x 🍊 = 2.7l/min 🍹

PERFORMING FRESHNESS WHEN YOU CAN GO A STEP FURTHER.

We offer solutions with maximum performance and efficiency for the situations when every bit counts. The 8000 series is the key to your success if you manage a large supermarket or hypermarket, or if you are planning to produce fresh juice at a semi-industrial scale.

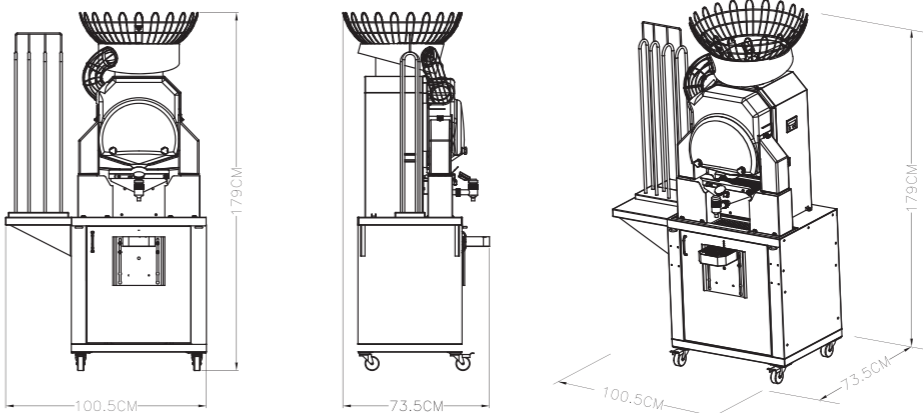

EVERYTHING CLOSE AT HAND AND READY TO USE



1

1 Bottle dispenser

Perfectly adapted to each bottle size. Can be mounted on the left- or right-hand side.

2 Glass tray

For perfect presentation at a buffet. Can be mounted on the left- or right-hand side.

3 Cabinet

The stainless steel cabinet features a built-in waste container.

3



4

4 "Shop in shop" system

All in one: advertising space as well as storage for bottles and fruits, available in large (as pictured) or small (with module mounted only on the left or right). Make the most of your Citrocasa.

CUSTOM ACCESSORIES FOR EACH JUICER

ADAPT YOUR CITROCASA TO YOUR INDIVIDUAL NEEDS.

As varied as our machines and their potential applications are, there is no shortage of ways to adapt your Citrocasa to your specific requirements. From the elegant fruit basket to various juicing elements and the modular juice island concept, we offer a comprehensive array of accessories for you to optimize your business with fresh elements.

5 Small Pressing Kit

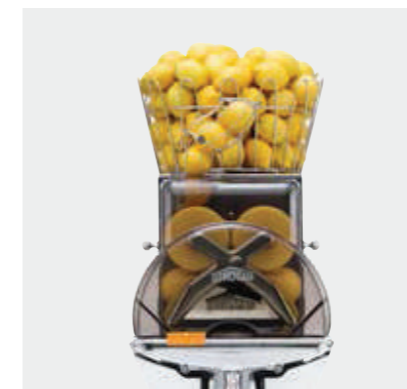

Ideal for lemons and small oranges with a diameter of 50 – 60 mm. Available for Fantastic and 8000 series machines.

6 Large Pressing Kit

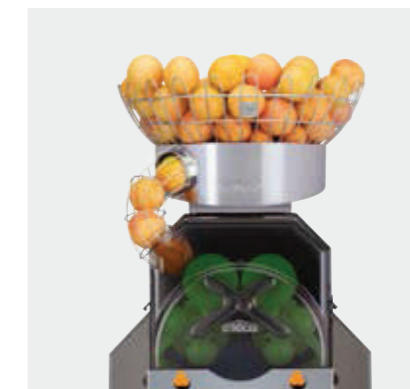

Ideal for grapefruits and large fruits with a diameter of 80 – 90 mm. Available for the 8000 series.

7 Fruit baskets

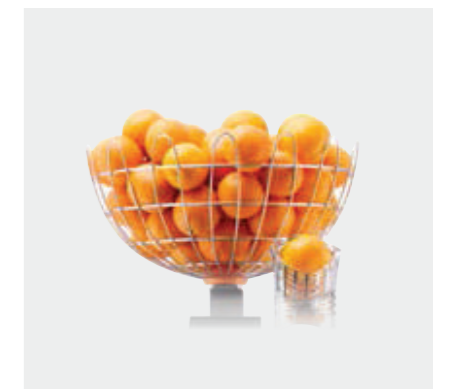

Fruit storage and presentation, both efficient and aesthetically pleasing. For the Fantastic M line, the Fantastic Eco and the Revolution.

8 Crushed ice cabinet



Allows attractive and accessible presentation of pre-pressed juices.

9 Double cabinet



The perfect solution for heavily frequented locations; offers enough space for two waste containers. Available for all 8000 series models.

10 Countertop installation kit



Integrate your Citrocasa seamlessly in your bar or presentation surface, so that peels disappear from your retail space without a trace.

11 Additional accessories

- Individual pedestals and distance adapters for small, medium and large glasses and bottles.
- Rectangular waste containers for up to 30 % increase in capacity
- Cover for the fruit basket for improved safety and hygiene
- Display refrigerator for storing and presenting pre-squeezed juices



**NATURALLY THE BEST ORANGES UNDER THE SUN. FLAVOUR!
JUICE! QUALITY! BECAUSE WE LIVE BY IT.**

Juice Me stands for the best freshly squeezed orange juice. In order to meet our quality standards, we leave conventions behind. Natural perfection in every detail is what sets Juice Me fruit apart!



**TREATED WITH CARE
PICKED WITH LOVE**

FRESH ORANGE JUICE 365 DAYS A YEAR



CITROCASA AND JUICE ME A TREASURED EXPERIENCE IN EACH DROP OF FRESH ORANGE JUICE.

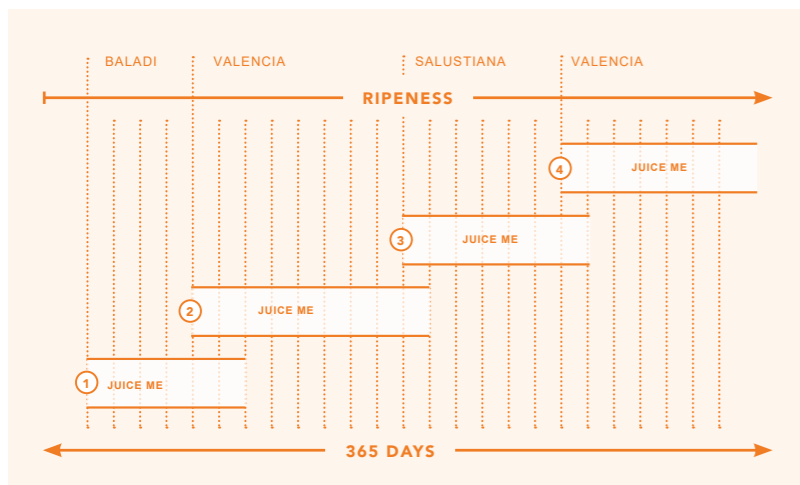

The best juice only comes from the best oranges. With that in mind, it is easy to see that the whole package needs to meet the same high standards. Citrocasa sees itself as a pioneer in this regard. The program we have developed to deliver the best quality oranges 365 days a year is a true challenge for everyone involved. But we use everything in our power to guarantee a glass of fresh orange juice. That's why we are able to provide a complete worry-free package, from the machine to oranges and bottles. All that is left for you and your customers is to enjoy the freshness.



OUR SEAL OF QUALITY

Not an imperfection – rather, a sign of the greatest quality. Sunshine and dew or raindrops lead to dark spots.

ONLY THE SUN DECIDES WHEN TO HARVEST.



CULTIVATION

Strict criteria for selecting suppliers and farmland.



GROWTH

Watering based on existing stock, fruit volume and precipitation.



RIPENESS

Complete development of nutrients, with ripening on the tree.



HARVEST

The ripe fruits are cut from the tree with care and by hand.



LOGISTICS

Cool temperatures and speed are vital to ensure fruit freshness.



FRUIT JUICE

All this combined with Citrocasa machine technology results in the best juice.

100% rPET PERFORMING SUSTAINABILITY

RECYCLED PET FOR INCREASED SUSTAINABILITY

- An environmentally conscious solution, these bottles consist 100% of recycled PET bottles.
- A bottle opening optimized for drinking ensures fuss-free enjoyment on the go.
- The resilient shape with a flexible base provides increased safety.
- Pleasant to hold thanks to the ergonomic shape.
- Available in the sizes: 0.25 l / 0.33 l / 0.5 l / 1.0 l

iSqueeze
let's get juicing!



rPET: recyceltes PET



DOING THE RIGHT THING IS IN OUR NATURE.

Our goal is to avoid producing any new plastic waste. No new PET is produced for our bottles, since only 100% recycled PET is used. That way, we help to protect valuable resources.



ALWAYS SETTING NEW GOALS.

We want to protect natural resources and surpass our high quality standards time and again. Our new rPET bottles help us do both – conserve raw materials and provide the ideal material properties for the best quality juice.



LIVING SUSTAINABILITY IN ALL AREAS.

That means building sustainable and long-lasting machines, achieving a responsible concept with our JUICE ME fruit and – last but not least – establishing sustainability as our guiding principle in packaging as well, with the launch of our rPET bottles made of 100% recycled material.



FRESH JUICE EXTRACTOR

FRESH Juice Extractor

ES 500

medium size juice bars

COMPACT & LIGHTWEIGHT FUNCTIONAL & QUIETER THAN EVER

- Non-stop service
- Dishwashing quick & easy
- Easy assembling
- Pulp Retainer
- Light alloy body
- Ceado Silent System



Voltage	220-240 V - 50-60 hz
Power	700 W
Rpm 50hz / 60hz	3000 / 3600 rpm
Net weight	14,4 kg
Gross weight	16,4 kg
Dimensions	242 x 495 x 512h mm
Feed Chute	ø 75 mm
Note	Additional voltage models available

TWO LITRES OF JUICE IN JUST A MINUTE!

- Non-stop service
- Dishwashing quick & easy
- Easy assembling
- Pulp Retainer
- Light alloy body
- Ceado Silent System



Voltage	220-240 V - 50-60 hz
Power	800 W
Rpm 50hz / 60hz	3000 / 3600 rpm
Net weight	19,2 kg
Gross weight	21,5 kg
Dimensions	290 x 538 x 512h mm
Feed Chute	ø 50 mm - ø 75 mm
Note	Additional voltage models available

FRESH Juice Extractor

ES 700

high turnover juice bars

FRESH Juice Extractor

ES 900

turnover juice bars

HEAVY DUTY INCREASED OUTPUT

- Non-stop service
- Dishwashing quick & easy
- Easy assembling
- Pulp Retainer
- Light alloy body
- Ceado Silent System



Voltage	220-240 V - 50-60 hz
Power	1000 W
Rpm 50hz / 60hz	3000 / 3600 rpm
Net weight	23,0 kg
Gross weight	27,0 kg
Dimensions	290 x 538 x 530h mm
Feed Chute	ø 50 mm - ø 75 mm
Note	Additional voltage models available



BLENDERS

Ceado

BLENDER

B280

PERFECT BLENDS EVEN DURING THE MOST INTENSE WORKING MOMENT

- Speed selection
- Pulse mode
- 1.5l container
- Juice Fit design
- Dynamic Spin (B280)



B280

Voltage	220-240 V - 50-60 hz	220-240 V - 50-60 hz
Power	900 W	1300 W
Rpm	20000/24000 rpm	18000/28000 rpm
Net weight	3.9 kg	4.8 kg
Gross weight	4.9 kg	5.7 kg
Dimensions	170 x 170 x 460h mm	195 x 180 x 450h mm
Note	Additional voltage models available	Additional voltage models available

SMOOTHIES MILKSHAKES FROZEN DRINKS IN A COMPLETELY AUTOMATIC WAY

- 6 automatic cycles
- Manual mode
- Square 1.5l jug
- Juice Fit design
- Dynamic Spin



B283

Yield and texture of the blend are optimised with the design of the new Dynamic Spin blades.

Rese e consistenza del blend sono ottimizzati dal disegno delle nuove lame Dynamic Spin.

Voltage	220-240 V - 50-60 hz
Power	1300 W
Rpm	6000/28000 rpm
Net weight	4.9 kg
Gross weight	5.8 kg
Dimensions	195 x 180 x 450h mm
Note	Additional voltage models available

BLENDER

B283

BLENDER

B285

MADE TO LOWER NOISE THANKS TO THE SILENT SYSTEM COVER

- App automatic cycles
- Manual mode
- Square 1.5l jug
- Juice Fit design
- Dynamic Spin
- Ceado Silent System



Voltage	220-240 V - 50-60 hz	220-240 V - 50-60 hz
Power	1300 W	1300 W
Rpm	6000/28000 rpm	6000/28000 rpm
Net weight	8.4 kg	8.8 kg
Gross weight	9.6 kg	9.7 kg
Dimensions	195 x 315 x 330h mm (h355 open)	195 x 220 x 486h mm (h501 open)
Note	Additional voltage models available	Additional voltage models available

JUICING STATIONS

1. RETRIEVE BOTTLE



2. PUSH TO FILL



3. SEAL FIRMLY



4. PAY AT CASH POINT



SMOOTHIES

FROZEN FRUIT

iSqueeze offers an extensive range of 100% IQF delicious, nutritious fruit and vegetable smoothies made for your convenience.

Our frozen fruit is Individually Quick Frozen (IQF). In terms of nutritional value, freezing is the best way of preserving fruit, freezing arrests the product at peak ripeness, preserving the vitamins and minerals which makes fruit so nutritious and more importantly removes any wastage that commonly exists with the use of fresh produce, therefore saving you money. The advantages of frozen are endless.

We have a wide wholesale range of premium quality GRADE A IQF frozen fruits.

All our fruits are fully traceable. Choose from our many varieties, from Avacado to Mango to Strawberry or even Mixed Berries. Available in 10kg boxes. Great for creating quick, unique and profitable smoothies and shakes, toppings for yogurt and ice cream or jams and chutneys.

1. OPEN



2. BLEND









3. DRINK



FRESH FRUIT SMOOTHIES

VEGGIE SMOOTHIES

 BERRY BURST Blueberry & strawberry	 BERRY ENERGISER Blackberry, blackcurrant & strawberry	 CARIBBEAN BREEZE Pineapple, strawberry & coconut
 MANGO TWISTER Mango & raspberry	 STRAWBERRY SPLIT Strawberry & banana	
 SWEET MELODY Mango, melon & strawberry	 TROPICAL DELIGHT Peach, passion fruit & mango	

 VEGGIE TWIST Ginger, apple, spinach, carrot & lemon zest	 THE GREEN MACHINE Broccoli, spinach, celery, banana & pineapple	 MIGHTY GREEN Apple, pear, kiwi, mint & avocado
 BEET N BLEND Beetroot, raspberry & banana	 MORNING GLORY Spinach, mango, pineapple & banana	

 BLACKBERRIES	 PEACH	 PINEAPPLE	 MIXED BERRIES
 STRAWBERRY	 BANANA	 AVACADO	 KIWI
 MANGO	 BLACKCURRANTS	 CHERRY	 MELON
 APPLE	 PAPAYA	 SPINACH	

iSqueeze

let's get juicing!



iSqueeze Ltd | marketing@isqueeze.co.uk | www.isqueeze.co.uk